

**BS EN 71-1:2011+A3:2014**



**BSI Standards Publication**

# **Safety of toys**

Part 1: Mechanical and physical properties

**bsi.**

...making excellence a habit.™

## National foreword

This British Standard is the UK implementation of EN 71-1:2011+A3:2014. It supersedes BS EN 71-1:2011+A2:2013 which is withdrawn.

It should be noted that, for playhouses additional requirements for maximum height, protruding parts, barriers, ladders etc, and entrapment are specified in BS EN 71-8.

The start and finish of text introduced or altered by amendment is indicated in the text by tags. Tags indicating changes to CEN text carry the number of the CEN amendment. For example, text altered by CEN amendment A2 is indicated by A2 A2.

The UK participation in its preparation was entrusted to Technical Committee CW/15, Safety of toys.

A list of organizations represented on this committee can be obtained on request to its secretary.

This publication does not purport to include all the necessary provisions of a contract. Users are responsible for its correct application.

© The British Standards Institution 2014.  
Published by BSI Standards Limited 2014

ISBN 978 0 580 79411 7

ICS 97.200.50

**Compliance with a British Standard cannot confer immunity from legal obligations.**

This British Standard was published under the authority of the Standards Policy and Strategy Committee on 30 June 2011.

### Amendments/corrigenda issued since publication

Date	Text affected
31 October 2013	Implementation of CEN amendment A2:2013. National foreword text updated
30 April 2014	Implementation of CEN amendment A3:2014

ICS 97.200.50

English Version

## Safety of toys - Part 1: Mechanical and physical properties

Sécurité des jouets - Partie 1: Propriétés mécaniques et  
physiquesSicherheit von Spielzeug - Teil 1: Mechanische und  
physikalische Eigenschaften

This European Standard was approved by CEN on 25 May 2011 and includes Amendment 1 approved by CEN on 20 December 2013, Amendment 2 approved by CEN on 10 August 2013 and Amendment 3 approved by CEN on 20 December 2013.

CEN members are bound to comply with the CEN/CENELEC Internal Regulations which stipulate the conditions for giving this European Standard the status of a national standard without any alteration. Up-to-date lists and bibliographical references concerning such national standards may be obtained on application to the CEN-CENELEC Management Centre or to any CEN member.

This European Standard exists in three official versions (English, French, German). A version in any other language made by translation under the responsibility of a CEN member into its own language and notified to the CEN-CENELEC Management Centre has the same status as the official versions.

CEN members are the national standards bodies of Austria, Belgium, Bulgaria, Croatia, Cyprus, Czech Republic, Denmark, Estonia, Finland, Former Yugoslav Republic of Macedonia, France, Germany, Greece, Hungary, Iceland, Ireland, Italy, Latvia, Lithuania, Luxembourg, Malta, Netherlands, Norway, Poland, Portugal, Romania, Slovakia, Slovenia, Spain, Sweden, Switzerland, Turkey and United Kingdom.



EUROPEAN COMMITTEE FOR STANDARDIZATION  
COMITÉ EUROPÉEN DE NORMALISATION  
EUROPÄISCHES KOMITEE FÜR NORMUNG

**CEN-CENELEC Management Centre: Avenue Marnix 17, B-1000 Brussels**

## Contents

Page

Foreword.....	8
Introduction .....	10
1 Scope (see A.2) .....	11
2 Normative references .....	13
3 Terms and definitions .....	14
4 General requirements.....	22
4.1 Material cleanliness (see A.3).....	22
4.2 Assembly (see A.4).....	23
4.3 Flexible plastic sheeting (see A.5 and A.16).....	23
4.4 Toy bags .....	23
4.5 Glass (see 5.7 and A.6).....	23
4.6 Expanding materials (see A.7).....	23
4.7 Edges (see A.8) .....	24
4.8 Points and metallic wires (see A.9).....	24
4.9 Protruding parts (see A.10).....	25
4.10 Parts moving against each other .....	25
4.10.1 Folding and sliding mechanisms (see A.11).....	25
4.10.2 Driving mechanisms (see A.12).....	27
4.10.3 Hinges (see A.13).....	27
4.10.4 Springs (see A.14).....	27
4.11 Mouth-actuated toys and other toys intended to be put in the mouth (see A.15) .....	28
4.12 Balloons (see 4.3 and A.16) .....	28
4.13 Cords of toy kites and other flying toys (see A.17).....	28
4.14 Enclosures.....	28
4.14.1 Toys which a child can enter (see A.18).....	28
4.14.2 Masks and helmets (see A.19).....	29
4.15 Toys intended to bear the mass of a child (see A.20).....	30
4.15.1 Toys propelled by a child or by other means .....	30
4.15.2 Toy bicycles (see A.20) .....	34
4.15.3 Rocking horses and similar toys (see A.21) .....	35
4.15.4 Toys not propelled by a child .....	36
4.15.5 Toy scooters (see A.49) .....	36
4.16 Heavy immobile toys .....	38
4.17 Projectiles (see A.22).....	38
4.17.1 General.....	38
4.17.2 Projectile toys without stored energy.....	39
4.17.3 Projectile toys with stored energy .....	39
4.17.4 Bows and arrows .....	39
4.18 Aquatic toys and inflatable toys (see A.23) .....	39
4.19 Percussion caps specifically designed for use in toys and toys using percussion caps (see A.24) .....	40
4.20 Acoustics (see A.25).....	40
4.20.1 Exposure categories for time-averaged sound pressure levels.....	40
4.20.2 Emission sound pressure level limits .....	41
4.21 Toys containing a non-electrical heat source .....	45
4.22 Small balls (see 5.10 and A.48).....	46
4.23 Magnets (see A.51) .....	46

4.23.1	General .....	46
4.23.2	Toys other than magnetic/electrical experimental sets intended for children over 8 years .....	46
4.23.3	Magnetic/electrical experimental sets intended for children over 8 years .....	47
4.24	Yo-yo balls (see A.52) .....	47
4.25	Toys attached to food (see A.55) .....	47
5	Toys intended for children under 36 months .....	48
5.1	General requirements (see A.26) .....	48
5.2	Soft-filled toys and soft-filled parts of a toy (see A.27) .....	49
5.3	Plastic sheeting (see A.28) .....	49
5.4	Cords, chains and electrical cables in toys (see A.29) .....	49
5.5	Liquid-filled toys (see A.30) .....	51
5.6	Speed limitation of electrically-driven ride-on toys .....	51
5.7	Glass and porcelain (see 4.5 and A.6) .....	51
5.8	Shape and size of certain toys (see A.31) .....	51
5.9	Toys comprising monofilament fibres (see A.32) .....	52
5.10	Small balls (see also 4.22 and A.48) .....	52
5.11	Play figures .....	52
5.12	Hemispheric-shaped toys (see A.50) .....	53
5.13	Suction cups (see A.54) .....	55
5.14	Straps intended to be worn fully or partially around the neck (see A.53) .....	55
6	Packaging (see A.56) .....	55
7	Warnings, markings and instructions for use (see A.33) .....	56
7.1	General .....	57
7.2	Toys not intended for children under 36 months (see 4.22 and A.34) .....	57
7.3	Latex balloons (see 4.12 and A.16) .....	59
7.4	Aquatic toys (see 4.18 and A.23) .....	59
7.5	Functional toys (see A.35) .....	59
7.6	Hazardous sharp functional edges and points (see 4.7 and 4.8) .....	59
7.7	Projectiles (see 4.17.3 c) and 4.17.4 c) .....	59
7.7.1	Toys with projectiles which are able to discharge an object other than that provided with the toy .....	59
7.7.2	Toys capable of discharging a projectile with a kinetic energy greater than 0,08 J .....	60
7.8	Imitation protective masks and helmets (see 4.14.2 and A.19) .....	60
7.9	Toy kites (see 4.13) .....	60
7.10	Roller skates, inline skates, skateboards and certain other ride-on toys (see 4.15.1.2 and A.20) .....	60
7.10.1	Roller skates, inline skates and skateboards .....	60
7.10.2	Ride-on toys without a braking device .....	60
7.10.3	Electrically-driven ride-on toys .....	60
7.10.4	Instructions for use .....	61
7.11	Toys intended to be attached to or strung across a cradle, cot, or perambulator (see 5.4 f) .....	61
7.12	Liquid-filled teethingers (see 5.5) .....	61
7.13	Percussion caps specifically designed for use in toys (see 4.19) .....	61
7.14	Acoustics (see 4.19 and 4.20) .....	61
7.15	Toy bicycles (see 4.15.2.2) .....	62
7.16	Toys intended to bear the mass of a child (see 4.15.1.2, 4.15.2.2, 4.15.3 and 4.15.4) .....	62
7.17	Toys comprising monofilament fibres (see 5.9) .....	62
7.18	Toy scooters (see 4.15.5.2) .....	62
7.19	Rocking horses and similar toys (see 4.15.3 and A.21) .....	63
7.20	Magnetic/electrical experimental sets (see 4.23.3 and A.51) .....	63
7.21	Toys with electrical cables exceeding 300 mm in length (see 5.4 i) .....	63
7.22	Toys with cords or chains intended for children of 18 months and over but under 36 months (see 5.4 b), 5.4 c) and 5.4 g) .....	63
8	Test methods .....	63

8.1	General requirements for testing .....	63
8.2	Small parts cylinder (see 4.6, 4.11, 4.18, 4.23.2, 4.23.3, 4.25, 5.1, 5.2 and A.36).....	64
8.3	Torque test (see 4.6, 4.11, 4.14.2, 4.17, 4.18, 4.22, 4.23.2, 4.25, 5.1, 5.10, 5.12, 5.13 and Clause 6) .....	64
8.4	Tension test (see A.37).....	65
8.4.1	Apparatus .....	65
8.4.2	Procedure .....	65
8.5	Drop test (see 4.5, 4.6, 4.10.2, 4.14.2, 4.22, 4.23.2, 4.25, 5.1, 5.10, 5.12 and 5.13).....	67
8.6	Tip over test (see 4.10.2, 4.22, 4.23.2, 5.1, 5.10, 5.12 and 5.13) .....	67
8.7	Impact test (see 4.5, 4.6, 4.10.2, 4.14.2, 4.22, 4.23.2, 4.25, 5.1, 5.10, 5.12, 5.13 and A.38).....	68
8.8	Compression test (see 4.6, 4.14.2, 4.22, 4.23.2, 4.25, 5.1, 5.10, 5.12, 5.13 and A.39) .....	68
8.9	Soaking test (see 4.11, 4.23.2, 5.1, 5.10 and 5.12) .....	68
8.10	Accessibility of a part or component (see 4.5, 4.7, 4.8, 4.10.2, 4.10.4, 4.15.1.3, 4.21, 5.2 and 5.7) .....	69
8.10.1	Principle .....	69
8.10.2	Apparatus .....	69
8.10.3	Procedure .....	69
8.11	Sharpness of edges (see 4.5, 4.7, 4.9, 4.10.2, 4.14.2, 4.15.1.3 and 5.1) .....	70
8.11.1	Principle .....	70
8.11.2	Apparatus .....	71
8.11.3	Procedure .....	72
8.12	Sharpness of points (see 4.5, 4.8, 4.9, 4.10.2, 4.14.2, 4.15.1.3, 5.1 and A.40) .....	72
8.12.1	Principle .....	72
8.12.2	Apparatus .....	72
8.12.3	Procedure .....	73
8.13	Flexibility of metallic wires (see 4.8 and A.41).....	74
8.13.1	General.....	74
8.13.2	Metallic wires and other metallic components intended to be bent.....	74
8.13.3	Metallic wires likely to be bent .....	74
8.14	Expanding materials (see 4.6) .....	75
8.15	Leakage of liquid-filled toys (see 5.5 and A.42).....	75
8.16	Geometric shape of certain toys (see 5.8, 5.11 and A.43) .....	75
8.17	Durability of mouth-actuated toys (see 4.11 and A.44).....	76
8.17.1	Mouth-actuated projectile toys.....	76
8.17.2	Other mouth-actuated toys .....	76
8.18	Folding or sliding mechanisms (see 4.10.1 and A.45) .....	77
8.18.1	Loads .....	77
8.18.2	Toy pushchairs and perambulators .....	77
8.18.3	Other collapsible toys (see 4.10.1 c).....	78
8.19	Electric resistivity of cords (see 4.13) .....	78
8.20	Cords cross-sectional dimension (see 5.4 a) .....	78
8.21	Static strength (see 4.15.1.3, 4.15.1.5, 4.15.3, 4.15.4 and A.46).....	79
8.22	Dynamic strength (see 4.15.1.3) .....	80
8.22.1	Principle .....	80
8.22.2	Loads .....	80
8.22.3	Procedure .....	81
8.23	Stability .....	83
8.23.1	Toys intended to bear the mass of a child (see 4.15.1.4, 4.15.3 and 4.15.4).....	83
8.23.2	Heavy immobile toys (see 4.16).....	83
8.24	Determination of kinetic energy (see A.47) .....	83
8.24.1	Kinetic energy of projectiles (see 4.17.3) .....	83
8.24.2	Kinetic energy of bows and arrows (see 4.17.4).....	84
8.25	Plastic sheeting.....	84
8.25.1	Thickness (see 4.3, 5.3 and Clause 6) .....	84
8.25.2	Adhesion (see 5.3) .....	84
8.26	Brake performance .....	84
8.26.1	Brake performance for certain ride-on toys (see 4.15.1.5) .....	84

8.26.2	Brake performance for toy bicycles (see 4.15.2.3).....	85
8.26.3	Brake performance for toy scooters (see 4.15.5.5).....	85
8.27	Strength of toy scooter steering tubes (see 4.15.5.3).....	86
8.27.1	Resistance to downward forces .....	86
8.27.2	Resistance to upward forces .....	87
8.28	Determination of emission sound pressure levels (see 4.20).....	87
8.28.1	General .....	87
8.28.2	Test procedures.....	91
8.29	Determination of maximum design speed of electrically-driven ride-on toys (see 4.15.1.2, 4.15.1.5, 4.15.1.8 and 5.6).....	100
8.30	Measurement of temperature rises (see 4.21) .....	101
8.31	Toy chest lids (see 4.14.1 c)).....	101
8.31.1	General .....	101
8.31.2	Lid support.....	101
8.31.3	Durability test for vertically opening hinged lids .....	101
8.32	Small balls and suction cups test (see 4.17, 4.22, 4.25, 5.10 and 5.13) .....	101
8.32.1	Small balls and suction cups (see Clause 6).....	101
8.32.2	Small balls attached to a toy by a cord .....	102
8.33	Test for play figures (see 5.11).....	103
8.34	Tension test for magnets (see 4.23.2 and A.51) .....	103
8.34.1	General .....	103
8.34.2	Toys that contain more than one magnet or magnetic component.....	103
8.34.3	Toys that contain one magnet only .....	104
8.35	Magnetic flux index (see 4.23.2 and 4.23.3) .....	104
8.35.1	General .....	104
8.35.2	Apparatus.....	104
8.35.3	Procedure.....	105
8.35.4	Calculation of magnetic flux index .....	105
8.36	Perimeter of cords and chains (see 5.4 c) and 5.4 d)) .....	106
8.36.1	Test equipment .....	106
8.36.2	Test procedures.....	107
8.37	Yo-yo balls measurements (see 4.24) .....	110
8.37.1	Measurement of initial length $l_0$ .....	110
8.37.2	Measurement of elastic constant k.....	111
8.38	Breakaway feature separation test (see 5.4 b), 5.4 c) and 5.14) .....	112
8.39	Self-retracting cords (see 5.4 e)).....	113
8.40	Length of cords, chains and electrical cables (see 5.4 b), 5.4 c), 5.4 g), 5.4 h) and 5.4 i)).....	113
Annex A (informative) Background and rationale for this European Standard.....		114
A.1	General .....	114
A.2	Scope (see Clause 1).....	114
A.3	Material cleanliness (see 4.1) .....	114
A.4	Assembly (see 4.2) .....	115
A.5	Flexible plastic sheeting (see 4.3) .....	115
A.6	Glass (see 4.5 and 5.7).....	115
A.7	Expanding materials (see 4.6).....	115
A.8	Edges (see 4.7) .....	115
A.9	Points and metallic wires (see 4.8) .....	116
A.10	Protruding parts (see 4.9).....	116
A.11	Folding and sliding mechanisms (see 4.10.1) .....	117
A.12	Driving mechanisms (see 4.10.2).....	117

<b>A.13</b>	<b>Hinges (see 4.10.3).....</b>	<b>117</b>
<b>A.14</b>	<b>Springs (see 4.10.4) .....</b>	<b>118</b>
<b>A.15</b>	<b>Mouth-actuated toys and other toys intended to be put in the mouth (see 4.11) .....</b>	<b>118</b>
<b>A.16</b>	<b>Balloons (see 4.3, 4.12 and 7.3).....</b>	<b>118</b>
<b>A.17</b>	<b>Cords of toy kites (see 4.13) .....</b>	<b>119</b>
<b>A.18</b>	<b>Toys which a child can enter (see 4.14.1) .....</b>	<b>119</b>
<b>A.19</b>	<b>Masks and helmets (see 4.14.2 and 7.8) .....</b>	<b>119</b>
<b>A.20</b>	<b>Toys intended to bear the mass of a child (see 4.15 and 7.10).....</b>	<b>119</b>
<b>A.21</b>	<b>Rocking horses and similar toys (see 4.15.3).....</b>	<b>120</b>
<b>A.22</b>	<b>Projectiles (see 4.17) .....</b>	<b>121</b>
<b>A.23</b>	<b>Aquatic toys and inflatable toys (see 4.18 and 7.4).....</b>	<b>121</b>
<b>A.24</b>	<b>Percussion caps specifically designed for use in toys and toys using percussion caps (see 4.19).....</b>	<b>121</b>
<b>A.25</b>	<b>Acoustics (see 4.20) .....</b>	<b>122</b>
<b>A.26</b>	<b>General requirements for toys intended for children under 36 months (see 5.1).....</b>	<b>125</b>
<b>A.27</b>	<b>Soft-filled toys and soft-filled parts of a toy (see 5.2) .....</b>	<b>126</b>
<b>A.28</b>	<b>Adhesion of plastic sheeting (see 5.3) .....</b>	<b>126</b>
<b>A.29</b>	<b>Cords and chains in toys (see 5.4).....</b>	<b>126</b>
<b>A.30</b>	<b>Liquid-filled toys (see 5.5 and A.42).....</b>	<b>129</b>
<b>A.31</b>	<b>Shape and size of certain toys (see 5.8 and A.43).....</b>	<b>129</b>
<b>A.32</b>	<b>Toys comprising monofilament fibres (see 5.9) .....</b>	<b>129</b>
<b>A.33</b>	<b>Warnings, markings and instructions for use (see 7.1).....</b>	<b>129</b>
<b>A.34</b>	<b>Warning for toys not intended for children under 36 months (see 7.2) .....</b>	<b>131</b>
<b>A.35</b>	<b>Warnings in connection with functional toys (see 7.5) .....</b>	<b>131</b>
<b>A.36</b>	<b>Small parts cylinder (see 8.2) .....</b>	<b>131</b>
<b>A.37</b>	<b>Tension test (see 8.4) .....</b>	<b>131</b>
<b>A.38</b>	<b>Impact test (see 8.7) .....</b>	<b>131</b>
<b>A.39</b>	<b>Compression test (see 8.8) .....</b>	<b>131</b>
<b>A.40</b>	<b>Sharpness of points (see 8.12).....</b>	<b>131</b>
<b>A.41</b>	<b>Flexibility of metallic wires (see 8.13).....</b>	<b>132</b>
<b>A.42</b>	<b>Leakage of liquid-filled teethingers (see 8.15 and A.30) .....</b>	<b>132</b>
<b>A.43</b>	<b>Geometric shape of certain toys (see 8.16 and A.31) .....</b>	<b>132</b>
<b>A.44</b>	<b>Durability of mouth-actuated toys (see 8.17).....</b>	<b>132</b>
<b>A.45</b>	<b>Folding or sliding mechanisms (see 8.18) .....</b>	<b>132</b>
<b>A.46</b>	<b>Static strength (see 8.21) .....</b>	<b>132</b>
<b>A.47</b>	<b>Kinetic energy of projectiles, bows and arrows (see 8.24) .....</b>	<b>132</b>
<b>A.48</b>	<b>Small balls (see 4.22 and 5.10) .....</b>	<b>133</b>
<b>A.49</b>	<b>Toy scooters (see 4.15.5) .....</b>	<b>134</b>



<b>A.50</b>	<b>Hemispheric-shaped toys (see 5.12)</b> .....	<b>134</b>
<b>A.51</b>	<b>Magnets (see 4.23)</b> .....	<b>135</b>
<b>A.52</b>	<b>Yo-yo balls (see 4.24)</b> .....	<b>137</b>
<b>A.53</b>	<b>Straps intended to be worn fully or partially around the neck (see 5.14)</b> .....	<b>140</b>
<b>A.54</b>	<b>Suction cups (see 5.13)</b> .....	<b>140</b>
<b>A.55</b>	<b>Toys attached to food (see 4.25)</b> .....	<b>140</b>
<b>A.56</b>	<b>Packaging (see Clause 6)</b> .....	<b>141</b>
<b>Annex B (informative)</b>	<b>Significant technical changes between this European Standard and the previous version</b> .....	<b>143</b>
<b>Annex ZA (informative)</b>	<b>Clauses of this European Standard addressing essential requirements or other provisions of EU Directives</b> .....	<b>145</b>
<b>Bibliography</b>	.....	<b>147</b>

## Foreword

This document (EN 71-1:2011+A3:2014) has been prepared by Technical Committee CEN/TC 52 "Safety of toys", the secretariat of which is held by DS.

This European Standard shall be given the status of a national standard, either by publication of an identical text or by endorsement, at the latest by September 2014, and conflicting national standards shall be withdrawn at the latest by September 2014.

This document supersedes  $\square_{A3}$  EN 71-1:2011+A2:2013  $\square_{A3}$ .

This document includes Amendments 1 and 3 approved by CEN on 2013-12-20 and Amendment 2 approved by CEN on 2013-08-10.

The start and finish of text introduced or altered by amendment is indicated in the text by tags  $\square_{A1}$   $\square_{A1}$ ,  $\square_{A2}$   $\square_{A2}$  and  $\square_{A3}$   $\square_{A3}$ .

Annex B provides details of significant technical changes between this European Standard and the previous edition.

This European Standard has been prepared under a mandate given to CEN by the European Commission and the European Free Trade Association, and supports essential requirements of EU Directive 2009/48/EC.

For relationship with EU Directive 2009/48/EC, see informative Annex ZA, which is an integral part of this European Standard.

Attention is drawn to the possibility that some of the elements of this document may be the subject of patent rights. CEN [and/or CENELEC] shall not be held responsible for identifying any or all such patent rights.

This European Standard constitutes the first part of the European Standard on safety of toys.

This European Standard for safety of toys consists of the following parts:

- Part 1: *Mechanical and physical properties*
- Part 2: *Flammability*
- Part 3: *Migration of certain elements*
- Part 4: *Experimental sets for chemistry and related activities*
- Part 5: *Chemical toys (sets) other than experimental sets*
- Part 7: *Finger paints — Requirements and test methods*
- Part 8: *Activity toys for domestic use*
- Part 9: *Organic chemical compounds — Requirements*
- Part 10: *Organic chemical compounds — Sample preparation and extraction*
- Part 11: *Organic chemical compounds — Methods of analysis*

NOTE 1 In addition to the above parts of EN 71, the following guidance documents have been published: CEN Report, CR 14379, *Classification of toys - Guidelines*, CEN Technical Report CEN/TR 15071, *Safety of toys - National translations*

*of warnings and instructions for use in EN 71, and CEN Technical Report CEN/TR 15371, Safety of toys – Replies to requests for interpretation of EN 71-1, EN 71-2, and EN 71-8.*

NOTE 2 Different legal requirements may exist in non-EU countries.

According to the CEN/CENELEC Internal Regulations, the national standards organisations of the following countries are bound to implement this European Standard: Austria, Belgium, Bulgaria, Croatia, Cyprus, Czech Republic, Denmark, Estonia, Finland, Former Yugoslav Republic of Macedonia, France, Germany, Greece, Hungary, Iceland, Ireland, Italy, Latvia, Lithuania, Luxembourg, Malta, Netherlands, Norway, Poland, Portugal, Romania, Slovakia, Slovenia, Spain, Sweden, Switzerland, Turkey and the United Kingdom.

## **Introduction**

This European Standard aims at reducing as far as possible those hazards which are not evident to users; it does not cover inherent hazards (e.g. instability of two-wheeled scooters, sharp needles in a sewing kit etc.) that are obvious to children or the persons in charge of them. Assuming that the toys are used in the intended manner they should not present any further hazard to children for whom they are intended (according to Directive 2009/48/EC “intended for use by” means that a parent or supervisor shall reasonably be able to assume by virtue of the functions, dimensions and characteristics of a toy that it is intended for use by children of the stated age group”). Allowance should also be made for foreseeable use, bearing in mind the behaviour of children who do not generally share the same degree of care as the average adult user.

As a general rule, toys are designed and manufactured for particular ages of children. Their characteristics are related to the age and stage of development of the children, and their use presupposes certain aptitudes.

Accidents are frequently due to a toy either being given to a child for whom it is not intended, or being used for a purpose other than that for which it was designed. Great care should therefore be taken when choosing a toy or game; account should be taken of the mental and physical development of the child who will be using it.

The requirements of this European Standard do not release parents or carers from their responsibility of watching over the child while he or she is playing.

## **1 Scope (see A.2)**

This European Standard specifies requirements and methods of tests for mechanical and physical properties of toys.

This European Standard applies to toys for children, toys being any product or material designed or intended, whether or not exclusively, for use in play by children of less than 14 years. It refers to new toys taking into account the period of foreseeable and normal use, and that the toys are used as intended or in a foreseeable way, bearing in mind the behaviour of children.

It includes specific requirements for toys intended for children under 36 months, children under 18 months and for children who are too young to sit up unaided. According to Directive 2009/48/EC “intended for use by” means that a parent or supervisor shall reasonably be able to assume by virtue of the functions, dimensions and characteristics of a toy that it is intended for use by children of the stated age group. Therefore, for the purpose of this European Standard, e.g. *soft-filled toys* with simple features intended for holding and cuddling are considered as toys intended for children under 36 months.

NOTE Information relating to the age grading of toys and, in particular, which toys are intended for children under 36 months and which toys are not, can be found in CEN Report CR 14379, the Consumer Product Safety Commission (CPSC) Age determination guidelines, CEN/CENELEC Guide 11 and the European Commission’s Guidance Documents.

This European Standard also specifies requirements for *packaging*, marking and labelling.

This European Standard does not cover musical instruments, sports equipment or similar items but does include their toy counterparts.

This European Standard does not apply to the following toys:

- playground equipment intended for public use;
- automatic playing machines, whether coin operated or not, intended for public use;
- toy vehicles equipped with combustion engines (see A.2);
- toy steam engines;
- slings and catapults.

Items that are propelled into free flight by a child releasing an elastic band (e.g. aeroplanes and rockets) are considered as catapults (see 5th indent above).

This European Standard does not cover electrical safety aspects of toys. These are covered by EN 62115.

Furthermore, it does not cover the following items which, for the purpose of this European Standard, are not considered as toys:

- decorative objects for festivities and celebrations;
- products for collectors, provided that the product or its *packaging* bears a visible and legible indication that it is intended for collectors of 14 years of age and above. Examples of this category are:
  - detailed and faithful scale models (see A.2);
  - kits for the assembly of detailed scale models;

- folk dolls and decorative dolls and other similar articles;
- historical replicas of toys;
- reproductions of real fire arms;
- sports equipment including roller skates, inline skates, and skateboards intended for children with a body mass of more than 20 kg;
- bicycles with a *maximum saddle height* of more than 435 mm, measured as the vertical distance from the ground to the top of the seat surface, with the seat in a horizontal position and with the seat pillar set to the minimum insertion mark;
- *scooters* and other means of transport designed for sport or which are intended to be used for travel on public roads or public pathways;
- electrically driven vehicles which are intended to be used for travel on public roads, public pathways, or the pavement thereof;
- aquatic equipment intended to be used in deep water, and swimming learning devices for children, such as swim seats and swimming aids;
- puzzles with more than 500 pieces;
- guns and pistols using compressed gas, with the exception of water guns and water pistols;
- bows for archery over 120 cm long;
- fireworks, including percussion caps which are not specifically designed for toys;
- products and games using sharp-pointed missiles, such as sets of darts with metallic points;
- functional educational products, such as electric ovens, irons or other *functional products*, as defined in 2009/48/EC, operated at a nominal voltage exceeding 24 V which are sold exclusively for teaching purposes under adult supervision;
- products intended for use for educational purposes in schools and other pedagogical contexts under the surveillance of an adult instructor, such as science equipment;
- electronic equipment, such as personal computers and game consoles, used to access interactive software and their associated peripherals, unless the electronic equipment or the associated peripherals are specifically designed for and targeted at children and have a play value on their own, such as specially designed personal computers, key boards, joy sticks or steering wheels;
- interactive software, intended for leisure and entertainment, such as computer games, and their storage media, such as CDs;
- babies' soothers;
- child-appealing luminaires;
- electrical transformers for toys;
- fashion accessories for children which are not for use in play (see A.2);

- personal protective equipment, including flotation aids such as arm bands and swim seats (see A.23); and swimming goggles, sunglasses and other eye protectors as well as bicycle and skateboard helmets (see A.19).

## 2 Normative references

The following referenced documents are indispensable for the application of this document. For dated references, only the edition cited applies. For undated references, the latest edition of the referenced document (including any amendments) applies.

EN 71-8, *Safety of toys — Part 8: Swings, slides and similar activity toys for indoor and outdoor family domestic use*

EN 15649-3, *Floating leisure articles for use on and in the water — Part 3: Additional specific safety requirements and test methods for Class A devices*

<sup>A2</sup> EN 50332-1, *Sound system equipment: Headphones and earphones associated with portable audio equipment – Maximum sound pressure level measurement methodology and limit considerations – Part 1: General method for “one package equipment”* <sup>A2</sup>

<sup>A2</sup> deleted text <sup>A2</sup>

<sup>A2</sup> EN 60318-4, *Electroacoustics — Simulators of human head and ear — Part 4: Occluded ear simulator for the measurement of earphones coupled to the ear by ear inserts (IEC 60318-4)* <sup>A2</sup>

<sup>A2</sup> deleted text <sup>A2</sup>

<sup>A2</sup> EN 61672-1, *Electroacoustics — Sound level meters — Part 1: Specifications (IEC 61672-1)* <sup>A2</sup>

<sup>A2</sup> deleted text <sup>A2</sup>

EN ISO 868, *Plastics and ebonite — Determination of indentation hardness by means of a durometer (Shore hardness) (ISO 868:2003)*

<sup>A2</sup> EN ISO 3744, *Acoustics — Determination of sound power levels and sound energy levels of noise sources using sound pressure — Engineering methods for an essentially free field over a reflecting plane (ISO 3744:2010)*

EN ISO 3745, *Acoustics — Determination of sound power levels and sound energy levels of noise sources using sound pressure — Precision methods for anechoic rooms and hemi-anechoic rooms (ISO 3745)* <sup>A2</sup>

<sup>A2</sup> EN ISO 3746, *Acoustics — Determination of sound power levels and sound energy levels of noise sources using sound pressure — Survey method using an enveloping measurement surface over a reflecting plane (ISO 3746)* <sup>A2</sup>

EN ISO 4287, *Geometrical product specifications (GPS) - Surface texture: Profile method - Terms, definitions and surface texture parameters (ISO 4287:1997)*

EN ISO 6508-1, *Metallic materials - Rockwell hardness test - Part 1: Test method (scales A, B, C, D, E, F, G, H, K, N, T) (ISO 6508-1:2005)*

<sup>A2</sup> EN ISO 11201, *Acoustics — Noise emitted by machinery and equipment — Determination of emission sound pressure levels at a work station and at other specified positions in an essentially free field over a reflecting plane with negligible environmental corrections (ISO 11201)* <sup>A2</sup>

EN ISO 11202, *Acoustics — Noise emitted by machinery and equipment — Determination of emission sound pressure levels at a work station and at other specified positions applying approximate environmental corrections (ISO 11202)*

deleted text

ISO 4593, *Plastics — Film and sheeting — Determination of thickness by mechanical scanning*

ISO 7619-2, *Rubber, vulcanized or thermoplastic — Determination of indentation hardness — Part 2: IRHD pocket meter method*

IEC/TS 60318-7, *Electroacoustics — Simulators of human head and ear — Part 7: Head and torso simulator for acoustic measurement of hearing aids*

### **3 Terms and definitions**

For the purpose of this document, the following terms and definitions apply.

#### **3.1**

##### **accessible**

contactable under the test conditions of 8.10 (accessibility of a part or component)

#### **3.2**

##### **aquatic toy**

toy, whether inflatable or not, intended for use in shallow water and which is capable of carrying or supporting a child on the water

#### **3.3**

##### **asphyxiation**

insufficient supply of air to the airways

NOTE Insufficient supply of air could be caused e.g. by closing off the flow of air as a result of *choking* or *suffocation* or by entrapment in an unventilated, confined space.

#### **3.4**

##### **backing**

material adhering to flexible *plastic sheeting*

#### **3.5**

##### **ball**

spherical, ovoid or ellipsoidal object, usually but not always designed or intended to be thrown, hit, kicked, rolled, dropped or bounced

NOTE The term *ball* also includes any multisided object formed by at least 48 connecting planes into a generally spherical, ovoid or ellipsoidal shape.

#### **3.6**

##### **burr**

roughness, caused by not cleanly severing or finishing the material

#### **3.7**

##### **cap-firing toy**

toy clearly designed to emit sound caused by discharge of a percussion cap

NOTE Examples of *cap-firing toys* include cap guns.



**A2 3.8 A2**

**chain**

connected series of links or rings

**A2 3.9 A2**

**choking**

closing off the flow of air as a result of internal *asphyxiation*

NOTE *Choking* can, for example, be caused by inhalation of an object, by an object becoming wedged in the mouth or pharynx, or by an object becoming lodged over the entrance to the lower airways.

**A2 3.10**

**close-to-the-ear toy**

toy clearly designed to emit sound, intended to be used within 2,5 cm of the ear

NOTE Examples of close-to-the-ear toys are toy telephones and toy rifles with a loudspeaker in the stock. **A2**

**A2 3.11 A2**

**collapse**

sudden or unexpected folding of a structure

**A2 3.12 A2**

**cord**

length of flexible textile or non-textile material including *elastic material*, monofilament polymeric material, *tape*, *ribbon*, rope, *strap*, woven and twisted material and string as well as certain weak and long *springs*

NOTE *Electrical cables* in toys are not considered to be *cords*.

**A2 3.13 A2**

**crack**

fracture of a material to the full thickness of the material

**A2 3.14 A2**

**crushing**

injury to part of the body resulting from compression between two surfaces

**A2 3.15 A2**

**driving mechanism**

assembly of linked parts of a toy, at least one of which moves and is driven either electrically, by clockwork or by other mechanical means and including gears, belts and winding mechanisms

**A2 3.16 A2**

**edge**

line formed at the junction of two surfaces, the length of which exceeds 2,0 mm

**A2 3.17 A2**

**elastic material**

material or item that is stretchable when subjected to an external force and which is able to recover or nearly recover its original length or shape when the force is removed

**A2 3.18 A2**

**electrical cable**

flexible insulated conductor used for connecting a toy to a supply of electricity or to a piece of electronic equipment which is not itself a toy or part of a toy

NOTE Electronic equipment includes computers and television sets which do not have a play value on their own.

**A2 3.19**

**emission sound pressure level**

sound pressure level at a specified position near a sound source, when the source is in operation under specified operating and mounting conditions on or above a reflecting plane surface, excluding the effects of background noise as well as the effects of reflections other than those from the plane or planes permitted for the purpose of the test **A2**

**A2 3.20 A2**

**expanding material**

material, the volume of which expands when exposed to water

**A2 3.21 A2**

**fastening**

mechanical device which attaches two or more components of a toy together (e.g. a screw)

**A2 3.22 A2**

**filling**

material intended to be wholly contained within a *soft-filled toy* or within *soft-filled* parts of a toy

**A2 3.23 A2**

**fixed drive**

transmission without *free-wheeling mechanism*

NOTE In a *fixed drive* the drive mechanism cannot be disengaged from the driven shaft. An example is a bicycle where the pedals are driven by the rear wheel when the bicycle is going downhill.

**A2 3.24 A2**

**fixed loop**

loop in a *cord*, the perimeter of which is fixed by any permanent means including a knot or knots

NOTE The *fixed loop* can include a part or parts of the toy (see Figure 1).

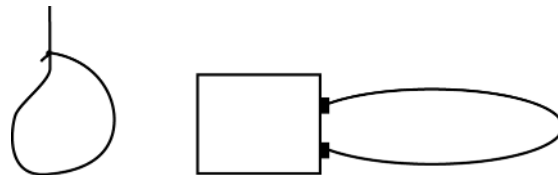

Figure 1 — Example of fixed loops

**A2 3.25 A2**

**free-wheeling mechanism**

transmission in which the drive mechanism is disengaged from the driven shaft when the driven shaft rotates faster than the drive mechanism

NOTE An example of the use of a *free-wheeling mechanism* is a bicycle which is going downhill without the pedals moving. Without a *free-wheeling mechanism* the rear wheel would drive the pedals around.

**A2 3.26 A2**

**functional edge or point**

*edge* or *point* which is essential for the functioning of a toy (e.g. microscope slides, electrical conductors, needles)

**A2 3.27 A2**

**functional magnet in electrical or electronic components of toys**

magnet necessary for the function of motors, relays, speakers and other electrical or electronic components in a toy where the magnetic properties are not part of the play pattern of the toy

**3.28**

**functional product**

product which performs and is used in the same way as a product, appliance or installation intended for use by adults, and which may be a scale model of such product, appliance or installation

**3.29**

**functional toy**

toy which performs and is used in the same way as a product, an appliance or an installation intended for use by adults and which may be a scale model of a such a product (e.g. a stove with heating properties)

**3.30**

**fuzz**

bits of fibrous type material that can be readily removed from toys with a pile surface

**3.31**

**hand-held toy**

toy clearly designed to emit sound, intended to be held in the hand but excluding *close-to-the-ear* toys, *rattles*, *squeeze toys*, *cap-firing toys*, *wind toys*, *voice toys* and *percussion toys*

NOTE Examples of hand-held toys are clicking toys, toy tools, and toy guns.

**3.32**

**hinge line**

line along or parallel to the line projected through the axis of rotation as shown in Figure 2

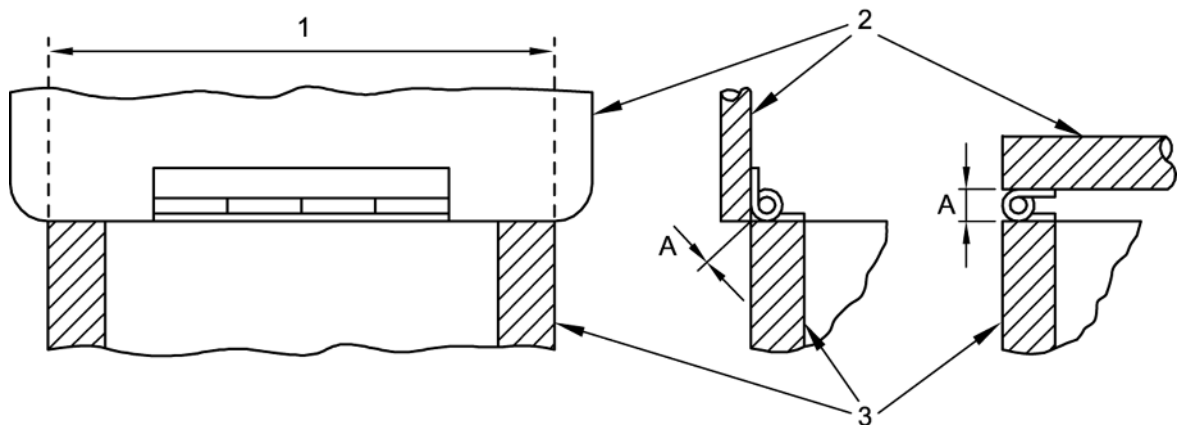

**Key**

- 1 *hinge line*
- 2 lid
- 3 box
- A hinge-line clearance between assembled edges

**Figure 2 — Definition of hinge line**

**3.33**

**large and bulky toy**

toy that has a projected base area of more than 0,26 m<sup>2</sup> or a volume of more than 0,08 m<sup>3</sup> calculated without regard to minor appendages, or a mass of 4,5 kg or more

NOTE The base area of a toy having permanently attached legs is the area enclosed by straight lines connecting the outermost *edge* of each leg of the perimeter.

**A2** 3.34 **A2**

**magnetic component**

part of a toy which contains an attached or fully- or partially-enclosed magnet

**A2** 3.35 **A2**

**magnetic/electrical experimental set**

toy containing one or more magnets intended for carrying out educational experiments involving magnetism and electricity

**A2** 3.36

**maximum emission sound pressure level**

highest instantaneous *emission sound pressure level* measured during a specified time interval using specified frequency and time-weighting

NOTE In this standard frequency weighting A and time-weighting F are specified and the quantity is denoted  $L_{AFmax}$ . **A2**

**A2** 3.37 **A2**

**maximum saddle height**

vertical distance from the ground to the top of the seat surface, measured with the seat in a horizontal position and with the seat pillar set to the minimum insertion mark

**A2** 3.38 **A2**

**noose**

loop in a *cord* which tightens as the *cord* is pulled (see Figure 3)



Figure 3 — Example of a noose

**A2** 3.39 **A2**

**overlap joint**

joint in which an *edge* overlaps a parallel surface but is not necessarily mechanically attached to it at all points along the length

**A2** 3.40 **A2**

**packaging**

material accompanying the toy when purchased but having no intended play function

**A3** 3.41

**paper**

sheet formed by irregularly intervened cellulose fibres with a mass per unit area of 400 g/m<sup>2</sup> or less **A3**

**A3** 3.42

**paperboard**

sheet formed by irregularly intervened cellulose fibres with a mass per unit area over 400 g/m<sup>2</sup> excluding pressed wooden fibreboards such as medium density fibreboard (MDF), chipboard and materials with similar properties

NOTE The term *paperboard* also includes materials commonly referred to as card or cardboard with a mass per unit area over 400 g/m<sup>2</sup>. **A3**

**A<sub>2</sub>** 3.43

**peak emission sound pressure level**

highest *emission sound pressure level* during a specified time interval recorded by a sound level meter using time-weighting *peak*

NOTE The *peak emission sound pressure level* is normally C-weighted and then denoted  $L_{pCpeak}$ .

**3.44**

**percussion toy**

toy clearly designed to emit sound when struck with a beater, such as a drumstick, or by the hand

NOTE Examples of *percussion toys* include drums, xylophones and tambourines. **A<sub>2</sub>**

**A<sub>3</sub>** 3.45 **A<sub>3</sub>**

**plastic sheeting**

thin section plastic sheeting which is used as part of the toy or as part of the *packaging*

**A<sub>3</sub>** 3.46 **A<sub>3</sub>**

**projectile**

object intended to be launched into free flight or a trajectory in the air

**A<sub>3</sub>** 3.47 **A<sub>3</sub>**

**projectile toy with stored energy**

toy with a *projectile* propelled by means of a discharge mechanism capable of storing and releasing energy

**A<sub>3</sub>** 3.48 **A<sub>3</sub>**

**projectile toy without stored energy**

toy with a *projectile* discharged by the energy imparted by a child

**A<sub>2</sub>** 3.49

**pull-along or push toy**

toy on which movement is imparted by the user for example by pulling it by a *cord* or pushing it by means of a rigid extension **A<sub>2</sub>**

**A<sub>2</sub>** 3.50

**rattle**

toy, intended for children who are too young to sit up unaided, that is clearly designed to emit sound when shaken or activated by the child or another person **A<sub>2</sub>**

**A<sub>3</sub>** 3.51 **A<sub>3</sub>**

**removable component**

part or component which is intended to be removed from the toy without the use of a *tool*

**A<sub>3</sub>** 3.52 **A<sub>3</sub>**

**ribbon**

narrow piece of fabric or textile material the width of which is significantly greater than the thickness

**A<sub>3</sub>** 3.53 **A<sub>3</sub>**

**soft-filled toy**

toy, clothed or unclothed, with soft body surfaces and filled with soft materials, readily allowing compression of the main part of the toy with the hand

**A<sub>3</sub>** 3.54 **A<sub>3</sub>**

**splinter**

sharp pointed fragment

**A3**

**3.55** **A3**  
**spring**

**A3** **3.55.1** **A3**  
**helical spring**

spring in the form of a coil, which can be either a *compression spring* or an *extension spring*, see Figure 4



**Figure 4 — Helical spring**

**A3** **3.55.2** **A3**  
**compression spring**

spring which returns to its initial state after release of the compressive force

**A3** **3.55.3** **A3**  
**extension spring**

*spring* which returns to its initial state after release of the tensile force

**A3** **3.55.4** **A3**  
**spiral spring**

clockwork type *spring*, see Figure 5



**Figure 5 — Spiral spring**

**A2** **3.56**  
**squeeze toy**

pliable toy, intended for children who are too young to sit up unaided, incorporating a sound-making feature activated by forcing air through an opening, clearly designed to emit sound when flexed or squeezed by the child or another person **A2**

**A3** **3.57** **A3**  
**strap**

strip of flexible material used for *fastening*, securing, carrying or holding

**A3** **3.58** **A3**  
**suction cup**

means of temporarily attaching a toy to a smooth surface made of soft, flexible, polymeric material, normally having a circular base which adheres to the surface when pressed against it, and in this way creating a vacuum

**A3** **3.59** **A3**  
**suffocation**

closing off the flow of air as a result of airway obstruction external to the mouth and nose

**A2 3.60**

**table-top or floor toy**

toy clearly designed to emit sound, intended to be used on a table, floor or another large surface

NOTE Examples of table-top or floor toys are toy cars, mechanical animals, and large and bulky toys. **A2**

**A3 3.61 A3**

**tangled loop**

loop created by twisting or snagging a *cord*, or *cords*, with attachments, knots or *fixed loops*

NOTE The *tangled loop* can include a part or parts of the toy (see Figure 6).

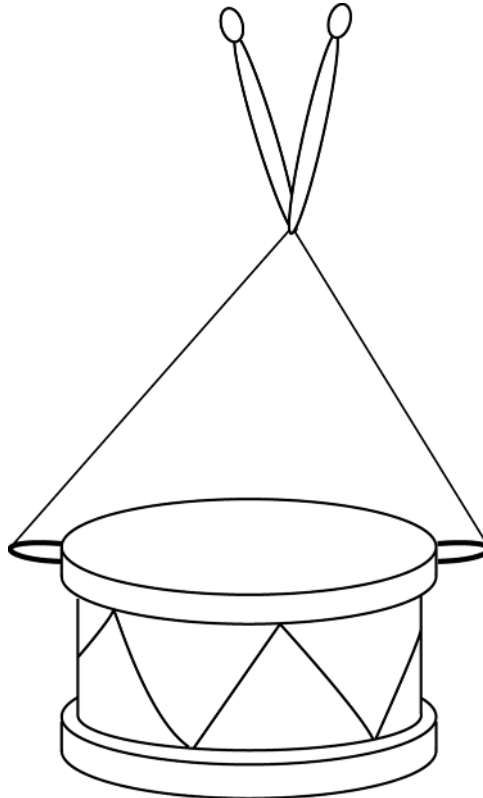

**Figure 6 — Example of tangled loop**

**A3 3.62 A3**

**tape**

narrow piece of non textile material the width of which is significantly greater than the thickness

**A3 3.63 A3**

**teether**

toy designed for oral use intended primarily for symptomatic relief of children's teething discomfort

**A2 3.64**

**time-averaged emission sound pressure level**

ten times the logarithm to the base 10 of the ratio of the time average of the square of the sound pressure during a stated time interval of duration to the square of a reference sound pressure, expressed in decibels, the sound pressure being obtained with a standard frequency weighting

NOTE The *time-averaged emission sound pressure level* is normally A-weighted and for the purpose of this standard then denoted  $L_{pA}$ . **A2**

**A3 3.65 A3**

**tool**

screwdriver, coin or any other object which can be used to operate a screw, clip or similar fixing device

**A3 3.66 A3**

**toy bag**

bag, clearly intended for use in play, often having features designed to encourage the child to use the bag in play activities

NOTE Bags that are *packaging* can be attractive to children for example if they are brightly coloured or have child appealing characteristics. Such characteristics alone are not enough to define them as *toy bags*

**A3 3.67 A3**

**toy bicycle**

two-wheeled vehicle, with or without stabilisers, with a *maximum saddle height* of 435 mm or less and which is propelled solely by the muscular energy of the person on that vehicle, in particular by means of pedals, and which has either a *free-wheeling mechanism* or a *fixed drive*

**A3 3.68 A3**

**toy scooter**

ride-on toy, not intended for sport or to be used for travel on public roads or public pathways, which is propelled by the muscular action of the user and may be foldable or not, intended for children with a body mass of 50 kg or less: comprising at least one platform for standing, at least two wheels, and a steering system equipped with an adjustable or fixed-length steering tube

**A2 3.69**

**voice toy**

toy clearly designed to emit sound by electronically amplifying or distorting the voice and where the output sound level depends on the input sound level of the voice

NOTE Examples of *voice toys* could include telephones, walkie-talkies, voice recording toys, sing-along microphones and electronic bull horns (toy megaphones).

**3.70**

**wind toy**

toy clearly designed to emit sound when actuated by the blowing action of the child or another person

NOTE Examples of *wind toys* include toy trumpets and toy whistles. **A2**

**A3 3.71 A3**

**yo-yo ball**

toy made from *elastic material* consisting of a tether usually having a loop at one end to place around a finger, and a flexible object at the other end

## **4 General requirements<sup>1</sup>**

### **4.1 Material cleanliness (see A.3)**

Toys and material used in toys shall be visually clean and free from infestation. The material shall be assessed visually by the unaided eye rather than under magnification.

---

<sup>1</sup> Words in *italics* are defined in Clause 3 (terms and definitions). Additional information on the background and rationale for various requirements is given in Annex A.



#### 4.2 Assembly (see A.4)

If a toy is intended to be assembled by a child, the requirements in this European Standard apply to each unit made available to the child and to the assembled toy. The requirements for the assembled toy do not apply to toys where the assembling provides a significant part of the play value of the toy.

If a toy is intended to be assembled by an adult, the requirements apply to the assembled toy.

Toys intended to be assembled shall be accompanied by detailed assembly instructions, if appropriate. The instructions shall indicate whether it is necessary that an adult assemble the toy or whether the proper assembly shall be checked by an adult before use.

#### 4.3 Flexible plastic sheeting (see A.5 and A.16)

Toys with flexible *plastic sheeting* shall conform to the following requirements:

Sheets without any *backing* and of an area greater than 100 mm × 100 mm shall:

- a) have an average thickness of 0,038 mm or more when tested according to 8.25.1 (plastic sheeting, thickness), or
- b) be perforated with defined holes so that a minimum of 1 % of the area has been removed over any area of 30 mm × 30 mm.

For plastic balloons, the requirements in 4.3 a) apply to double layers of *plastic sheeting* (i.e. the thickness is measured without inflating or destroying the balloon).

#### 4.4 Toy bags

*Toy bags* with an opening perimeter greater than 380 mm having a drawstring as a means of closure shall either:

- a) be made of material permeable to air, or
- b) comply with requirements given in 4.14.2 a) (masks and helmets).

#### 4.5 Glass (see 5.7 and A.6)

*Accessible* glass may be used in the construction of toys for children of 36 months and over where:

- a) its use is necessary to the function of the toy (e.g. optical toys, glass light bulbs, glass in experimental sets);
- b) it is textile glass used for reinforcement;
- c) it is in the form of solid glass marbles or solid glass eyes for dolls;
- d) it is in the form of other glass elements (e.g. glass beads) that after being subjected to 8.5 (drop test) and 8.7 (impact test) do not expose *accessible* hazardous sharp edges (see 8.11, sharpness of edges) or *accessible* hazardous sharp points (see 8.12, sharpness of points).

#### 4.6 Expanding materials (see A.7)

The requirement in 4.6 does not apply to seeds in growing kits.

*Expanding materials* in toys or components of toys which fit entirely in the cylinder specified in 8.2 (small parts cylinder) before or after being tested according to 8.3 (torque test), 8.4.2.1 (tension test, general), 8.5 (drop test), 8.7 (impact test) and 8.8 (compression test) shall not expand more than 50 % in any dimension when tested according to 8.14 (expanding materials).

If the *expanding material* is enclosed by a material intended to break during soaking, the requirement in 4.6 shall be fulfilled also when the test is performed after removal of the breakable material.

#### **4.7 Edges (see A.8)**

*Accessible edges* shall not present an unreasonable risk of injury.

- a) *Edges* of metal or glass are considered as potentially hazardous sharp *edges* if they are sharp as determined according to 8.11 (sharpness of edges). If the *edges* fail the test, they shall be assessed to determine whether they present an unreasonable risk of injury taking into account the foreseeable use of the toy. Regardless of the manner in which the *edges* are finished, they shall be tested according to 8.11.

NOTE *Edges* may be folded, rolled or spiralled in order to make them *inaccessible*, or protected by a coating of plastic or other similar material.

- b) In *overlap joints*, the *edge* of the sheet metal shall conform to 4.7 a) when the sheet metal has a thickness of 0,5 mm or less and the clearance to the underlying surface is greater than 0,7 mm.
- c) *Edges* of metal including *fastenings* (e.g. screw heads) and of rigid polymeric material shall be free from *burr* capable of causing wounds or abrasion.

Flashings on pliable polymeric materials (e.g. polyolefins) are not considered as *burr*.

- d) Where it is essential for the functioning of the toy, hazardous sharp *functional edges* may be used in toys intended for children of 36 months and over. The potential danger presented by such *edges* shall be drawn to the attention of the user (see 7.6). However, the sharpness of *edges* of pieces intended to serve as electric conductors, microscope slides and cover slips do not need to be drawn to the attention of the user.

#### **4.8 Points and metallic wires (see A.9)**

Metallic wires and *accessible* points shall not present an unreasonable risk of injury.

- a) Points are considered as potentially hazardous sharp points if they are sharp as determined according to 8.12 (sharpness of points). If the points fail the test, they shall be assessed to determine whether they present an unreasonable risk of injury taking into account the foreseeable use of the toy (see also 5.1 c)).

Points of pencils and similar writing and drawing implements are not considered as sharp points.

- b) Where it is essential for the functioning of the toy, hazardous sharp *functional points* may be used in toys intended for children of 36 months and over. The potential danger presented by such points shall be drawn to the attention of the user (see 7.6). However, the sharpness of points of pieces intended to serve as electrical conductors do not need to be drawn to the attention of the user.
- c) Metallic wires and other metallic components that are designed and intended to be bent, for example, in order to change the shape or position of a toy or part of a toy (e.g. in *soft-filled toys*), shall not break and produce hazardous sharp points, or protrude through any surface covering of the toy, when tested according to 8.13.2 (metallic wires and other metallic components intended to be bent).

- d) Metallic wires that are not designed to be bent but are likely to occasionally or accidentally be bent during play shall not break and produce hazardous sharp points, or protrude through any surface covering of the toy, when tested according to 8.13.3 (metallic wires likely to be bent).
- e) *Splinters* on surfaces and *accessible edges* of toys shall not present an unreasonable risk of injury taking into account the foreseeable use of the toy.

#### 4.9 Protruding parts (see A.10)

Tubes and rigid components in the form of projections which constitute a puncture hazard to a child shall be protected. This protection shall not be removed when tested according to 8.4.2.3 (tension test, protective components).

The ends of spokes on toy umbrellas shall be protected. If the protection is removed when tested according to 8.4.2.3 (tension test, protective components), the ends of the spokes shall be free from hazardous sharp *edges* and hazardous sharp points when tested according to 8.11 (sharpness of edges) and 8.12 (sharpness of points). In addition, if the protection is removed, the spokes shall have a diameter of 2 mm or more and shall have ends with no *burr* and a smooth, rounded and approximately spherical finish.

#### 4.10 Parts moving against each other

##### 4.10.1 Folding and sliding mechanisms (see A.11)

The requirements in 4.10.1 do not apply to toys with a potential sitting surface width of less than 140 mm.

Toys with folding and sliding mechanisms shall conform to the following requirements:

- a) Toy pushchairs and perambulators incorporating a handle or other structural member which can fold down over a child, shall have at least one main locking device and at least one secondary locking device, both of which shall act directly on the folding mechanism.

At least one of the locking devices shall automatically engage when the toy is erected.

When tested according to 8.18.2 a) (toy pushchairs and perambulators), the toy shall not *collapse* nor shall either of the locking devices fail or disengage.

Two devices of the same construction (e.g. locking rings), one on the left-hand side and one on the right-hand side of the toy, are considered to be one locking device.

If it is possible to partially erect a toy pushchair or perambulator without one of the locking devices being engaged, the test of 8.18.2 a) (toy pushchairs and perambulators) shall be performed in this orientation.

An example of a toy pushchair or perambulator covered by 4.10.1 a) is illustrated in Figure 7.

NOTE Partially erect means erected in such a way that the user might wrongly believe the toy to be fully erect.

- b) Toy pushchairs and perambulators that do not otherwise constitute a hazard of a handle or other structural member folding down over a child, shall have at least a locking device or a safety stop, which may be manual in operation.

When tested according to 8.18.2 b) (toy pushchairs and perambulators) the toy shall not *collapse* nor shall the locking device or safety stop fail or disengage.

If it is possible to partially erect a toy pushchair or perambulator without a locking device being engaged, the test of 8.18.2 b) shall be performed in this orientation (see also Note in 4.10.1 a)).

Examples of toy pushchairs covered by 4.10.1 b) are illustrated in Figure 8.

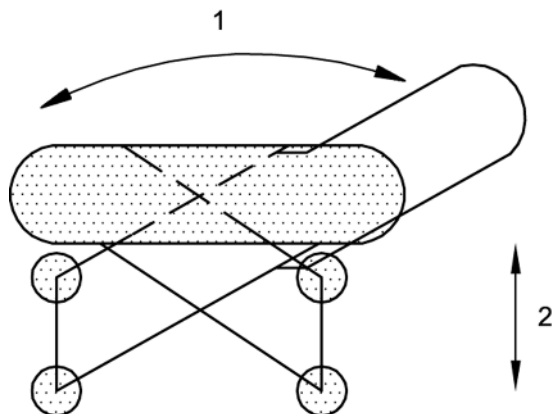

**Key**

- 1 handle movement
- 2 chassis movement

**Figure 7 — Example of toy pushchair or perambulator covered by 4.10.1 a)**

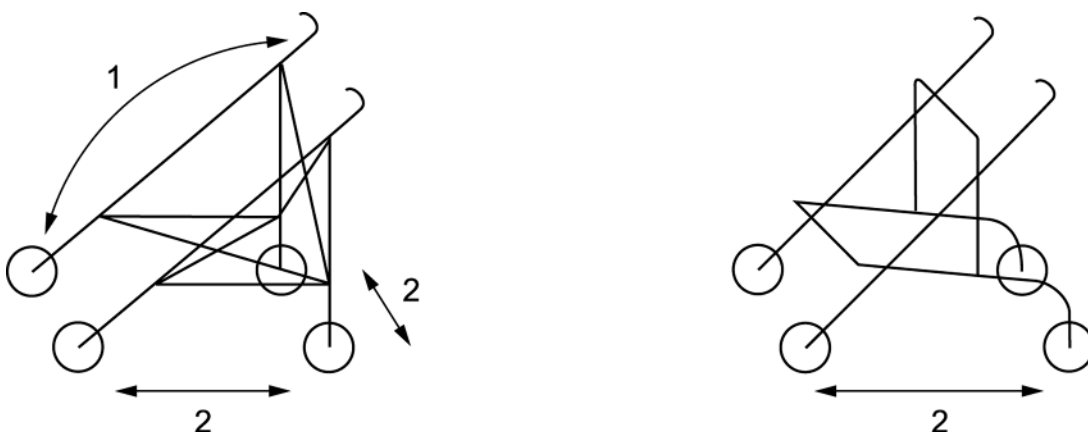

**Key**

- 1 handle movement
- 2 chassis movement

**Figure 8 — Examples of toy pushchairs covered by 4.10.1 b)**

- c) Folding devices on other collapsible toys (e.g. ironing boards, folding chairs and tables etc.) which may have a scissor-like action:
  - 1) shall have a safety stop or locking device. When tested according to 8.18.3 (other collapsible toys), the toy shall not *collapse* nor shall the locking device fail or disengage, and
  - 2) shall have a clearance of 12 mm or more between moving parts which constitute a scissor-like action.
- d) Toys other than those covered by 4.10.1 a), b) or c), with folding or sliding mechanisms intended to bear or capable of bearing the mass of a child and capable of injuring fingers, shall be so constructed that the space between moving elements shall also allow a 12 mm diameter rod to be inserted if it allows a 5 mm diameter rod to be inserted.

#### 4.10.2 Driving mechanisms (see A.12)

The requirements in 4.10.2 a) and b) do not apply to *driving mechanisms* with insufficient power to injure fingers or other parts of the body, nor to transmissions on toys intended to bear the mass of a child which are covered in 4.15.1.6.

*Driving mechanisms* and winder keys shall conform to the following requirements:

- a) *Driving mechanisms* shall be enclosed in such a way that they do not expose *accessible* hazardous sharp edges (see 8.11, sharpness of edges) or hazardous sharp points (see 8.12, sharpness of points) or otherwise present a hazard that could cause *crushing* of the fingers or other parts of the body when tested according to 8.5 (drop test) and 8.7 (impact test).
- b) *Driving mechanisms* within *large and bulky toys* shall be enclosed in such a way that they do not expose *accessible* hazardous sharp edges (see 8.11, sharpness of edges) or hazardous sharp points (see 8.12, sharpness of points) or otherwise present a hazard that could cause *crushing* of the fingers or other parts of the body when tested according to 8.6 (tip over test).
- c) The shape and dimensions of winder keys or starting handles shall be such that the clear space between the key or the handle and the body of the toy shall also allow a 12 mm diameter rod to be inserted if it allows a 5 mm diameter rod to be inserted. Any holes in keys or handles shall not permit the insertion of a 5 mm diameter rod.

#### 4.10.3 Hinges (see A.13)

The requirement in 4.10.3 does not apply if any part joined by one or more hinges has a mass of less than 250 g.

Toys having two parts joined by means of one or more hinges and with a space between the assembled edges along the *hinge line*, shall be so constructed that this space with the parts in any position shall also allow a 12 mm diameter rod to be inserted if it allows a 5 mm diameter rod to be inserted.

#### 4.10.4 Springs (see A.14)

*Springs* shall conform to the following requirements:

- a) *Spiral springs* shall not be *accessible* if the gap between two consecutive spirals is greater than 3 mm in any position of use.

The requirement in 4.10.4 b) does not apply to *springs* that do not return to their original position after unloading (i.e. if the elastic limit is exceeded).

- b) Extension *helical springs* shall not be *accessible* if the gap between two consecutive turns is greater than 3 mm when the *spring* is subjected to a tensile force of 40 N.

The requirement in 4.10.4 c) does not apply to *springs* that do not return to their original position after loading with a force of 40 N or to *springs* wound round a second component of the toy (for example a guiding rod) so that it is not possible to insert the *accessibility probe* A (see Figure 21, *accessibility probe*) between consecutive coils by more than 5 mm.

- c) Compression *helical springs* shall not be *accessible* if the gap between two consecutive turns is greater than 3 mm at rest, and the *spring* can be subjected to a force of 40 N or more when the toy is in use.

#### **4.11 Mouth-actuated toys and other toys intended to be put in the mouth (see A.15)**

Toys or parts of toys made of materials excluded from 5.1 (general requirements) are excluded from the requirements in 4.11 a), b) and d).

Toys intended to be put in the mouth shall conform to the following requirements:

- a) Toys intended to be put in the mouth, *removable* mouthpieces and other *removable components* of toys intended to be put in the mouth shall not fit entirely in the cylinder when tested according to 8.2 (small parts cylinder).
- b) Mouthpieces and other components of toys intended to be put in the mouth, excluding mouth-actuated *projectile* toys, if detached when tested first according to 8.9 (soaking test) and then according to 8.3 (torque test) and 8.4.2.1 (tension test, general), shall not fit entirely in the cylinder when tested according to 8.2 (small parts cylinder).
- c) Mouth-actuated toys which contain loose components such as spheres in a whistle or reeds in a noisemaker shall not, when tested according to 8.17.2 (other mouth-actuated toys), release any objects that fit entirely in the cylinder when tested according to 8.2 (small parts cylinder).
- d) Mouthpieces fitted to balloons shall conform to the requirements in 4.11 a) and b).
- e) Mouth-actuated *projectile* toys (e.g. peashooters) shall have a mouthpiece which does not allow the intended *projectiles* to pass through when tested according to 8.17.1 (mouth-actuated projectile toys), and thereafter does not become detached when tested according to 8.3 (torque test) and 8.4.2.1 (tension test, general).

#### **4.12 Balloons (see 4.3 and A.16)**

The *packaging* of latex balloons shall carry a warning (see 7.3).

The *packaging* of natural rubber latex balloons shall indicate that the balloons are made of natural rubber latex (see 7.3).

#### **4.13 Cords of toy kites and other flying toys (see A.17)**

*Cords* of toy kites and other flying toys linking the toy to the child and with a length of more than 2 m, shall be made of material with an electric resistance exceeding 100 M $\Omega$ /cm of *cord*, when measured according to 8.19 (electric resistivity of cords).

The potential danger of flying a toy kite near overhead power lines and during thunderstorms shall be drawn to the attention of the user by a warning (see 7.9).

#### **4.14 Enclosures**

##### **4.14.1 Toys which a child can enter (see A.18)**

Toys which a child can enter shall conform to the following requirements:

- a) Any toy having a door, lid or similar device which encloses a continuous volume greater than 0,03 m<sup>3</sup> and in which all internal dimensions are 150 mm or more, shall provide at least two unobstructed ventilation holes, each 650 mm<sup>2</sup> or more, situated at least 150 mm apart. The total ventilation area shall be provided when the toy is placed on the floor in any position and adjacent to two vertical plane surfaces meeting at a 90° angle, so as to simulate the corner of a room.

The ventilation area is not required if the continuous volume is effectively sub-divided into compartment(s) by a permanent partition(s) or one or more bars making at least one dimension in the compartment less than 150 mm.

- b) For such toys having a door, lid or similar device, it shall be possible to open the door, lid or similar device by applying a force of 50 N or less from the inside.

NOTE This requirement notably precludes the use of buttons, zips and similar *fastenings* on doors, lids or similar devices.

- c) Toy chests with vertically opening hinged lids shall be provided with lid-support mechanisms to prevent sudden *collapse* or dropping of the lid. The lid-support mechanism shall support the lid so that at no position in the arc of travel of the lid from within 50 mm of the fully closed position through an arc not to exceed 60° from the fully closed position shall it drop more than 12 mm under the influence of its own mass, except in the last 50 mm of travel. The test shall be performed according to 8.31.2 (lid support).

The lid-support mechanism shall conform to this requirement before and after being subjected to 7 000 opening and closing cycles, as described in 8.31.2 (durability test for vertically opening hinged lids).

The lid-support mechanism shall not require adjustment by the consumer to ensure adequate lid support, nor shall it require adjustment in order to conform to the above requirement after being cycled according to 8.31.2 (durability test for vertically opening hinged lids).

The lid and lid-support mechanism shall conform to the requirements in 4.10.3 (hinges).

Toys chests with vertically opening hinged lids shall be accompanied by instructions for proper assembly and maintenance.

#### **4.14.2 Masks and helmets (see A.19)**

Masks and helmets shall conform to the following requirements:

- a) Masks and helmets that fully enclose the head and which are made of impermeable material shall provide a total ventilation area of 1 300 mm<sup>2</sup> or more through at least two holes at least 150 mm apart or through any equivalent single ventilation area.

An example of an equivalent single ventilation area is given in Figure 9.

Dimensions in millimetres

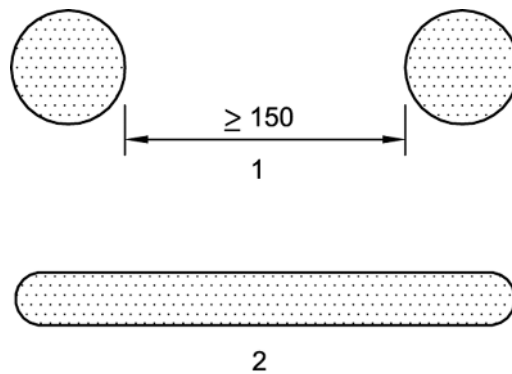

**Key**

- 1 total ventilation area, 1 300 mm<sup>2</sup> or more
- 2 alternative equivalent ventilation area, 1 300 mm<sup>2</sup> or more

**Figure 9 — Example of ventilation areas**

- b) All rigid materials that cover the face such as goggles, space helmets or face shields shall not expose hazardous sharp *edges* (see 8.11, sharpness of edges), hazardous sharp points (see 8.12, sharpness of points) or loose parts that could enter the eye, before and after being tested according to 8.3 (torque test), 8.4.2.1 (tension test, general), 8.5 (drop test), 8.7 (impact test) and 8.8 (compression test).

This also applies to toys made of rigid materials with cut-out eye holes and toys that cover the eyes.

- c) Toys that are imitations of protective masks and helmets (e.g. motorcycle helmets, industrial safety helmets and firemen's helmets) shall carry a warning (see 7.8).

#### 4.15 Toys intended to bear the mass of a child (see A.20)

##### 4.15.1 Toys propelled by a child or by other means

###### 4.15.1.1 General

Toys propelled by a child or by other means and intended to bear the mass of a child, e.g.:

- roller skates, inline skates and skateboards intended for children with a body mass of 20 kg or less,
- tricycles, cars, hand carts, moon-hoppers and pogo sticks,

shall conform to the requirements of the following sub-clauses of 4.15.1.

The requirements in 4.15.1.2 and 4.15.1.5 do not apply to *toy bicycles*, which are covered in 4.15.2, and to *toy scooters*, which are covered in 4.15.5.

###### 4.15.1.2 Warnings and instructions for use

Roller skates, inline skates and skateboards for children offered for sale as toys shall carry a warning regarding protective equipment (see 7.10.1).

Mechanically-driven ride-on toys that do not have a *free-wheeling mechanism* or a braking device, and are either intended to bear the mass of two or more children, or have an unloaded mass of 30 kg or more, shall carry a warning regarding the lack of a brake (see 7.10.2).



In addition, electrically-driven ride-on toys for which a brake is not required according to 4.15.1.5, shall carry a warning regarding the lack of a brake (see 7.10.2) if they do not have a *free-wheeling mechanism* or a braking device, and are either intended to bear the mass of two or more children, or have an unloaded mass of 30 kg or more.

Roller skates, inline skates, skateboards and electrically-driven ride-on toys where the electrical motor itself provides sufficient braking (see 4.15.1.5 a)) are not required to carry this warning.

Electrically-driven ride-on toys and/or their *packaging*, and their instructions for use, shall carry a warning regarding protective equipment (see 7.10.3). This warning is not required on electrically-driven ride-on toys that are equipped with a seat, and are either covered by the requirement in 4.15.1.4 or have a maximum design speed of less than 8,2 km/h when tested according to 8.29 (determination of maximum design speed of electrically-driven ride-on toys).

Electrically-driven ride-on toys shall carry a warning regarding the intended age group (see 7.10.3).

The *packaging* and the instructions for use of electrically-driven ride-on toys shall be accompanied by a warning regarding safe riding areas (see 7.10.3).

Toys intended to bear the mass of a child shall be accompanied by instructions for use, assembly and maintenance. The potential dangers of using the toy and precautions to be taken shall be brought to the attention of the user (see 7.10.4).

Toys that due to their construction, strength, design or other factors are not suitable for use by children of 36 months and over shall carry a warning (see 7.16).

#### **4.15.1.3 Strength**

Toys, when tested according to 8.21 (static strength) and 8.22 (dynamic strength) shall not:

- a) produce *accessible* hazardous sharp *edges* (see 8.11, sharpness of edges);
- b) produce *accessible* hazardous sharp points (see 8.12, sharpness of points);
- c) make *driving mechanisms accessible* that present a hazard that could cause *crushing* of the fingers or other parts of the body;
- d) *collapse* so that they do not continue to conform to relevant requirements of this European Standard.

#### **4.15.1.4 Stability**

The requirement in 4.15.1.4 does not apply to:

- roller skates, inline skates and toy skateboards;
- toys that by their design do not have a stable base (e.g. pogo sticks, moon hoppers);
- toys intended for children of 36 months and over where the feet of the child can provide sideways stability (i.e. where the legs are unrestricted in their sideways motion) and where the height of the seat is such that a child of the age group for which the toy is intended can reach the ground with both feet when seated (with fore and aft stability remaining);
- toys with aligned wheels. Wheels with a spacing of 150 mm or less between the centres of the outermost wheels are considered to be a single wheel.

The toy shall not tip over when tested according to 8.23.1 (stability, toys intended to bear the mass of a child).

#### **4.15.1.5 Braking**

The requirements in 4.15.1.5 do not apply to:

- roller skates, inline skates and toy skateboards;
  - toys where the hands or feet provide the motive power to the driving wheel(s) via direct transmission;
  - electrically-driven ride-on toys with a maximum design speed, when tested according to 8.29 (determination of maximum design speed of electrically-driven ride-on toys), of 1 m/s (3,6 km/h) or less, having a seat height below 300 mm and in which the feet are able to effect braking.
- a) Mechanically- or electrically-driven ride-on toys with a *free-wheeling mechanism* shall have a braking device. For such toys having a mass of 30 kg or more, it shall be possible to lock at least one brake in a braking position.

The toy shall not move more than 5 cm when tested according to 8.26.1 (brake performance for certain ride-on toys). This requirement applies to all brakes on toys covered by 4.15.1.5 regardless of whether or not a brake is required by this European Standard.

The requirement in 4.15.1.5 a) does not apply to electrically-driven ride-on toys on which the electrical motor itself supplies sufficient braking. The motor shall be considered to supply sufficient braking if:

- the average speed of the vehicle is less than or equal to 0,36 m/s (1,3 km/h) when tested according to 8.26.1.2 (motor brake performance – ramp test), or
- the following is fulfilled when tested according to 8.26.1.3 (motor brake performance – horizontal test):

$$FT1 \geq (M + 25) \times 1,7$$

or (1)

$$FT2 \geq (M + 50) \times 1,7 \quad (2)$$

where

FT1 is the maximum pull force in Newtons for a toy intended for children under 36 months;

FT2 is the maximum pull force in Newtons for a toy intended for children of 36 months and over;

M is the mass of the toy in kilograms.

- b) Electrically-driven ride-on toys shall be operated by means of a switch which cuts off the power automatically when it is released, without tilting the toy. Application of the brakes, if present, shall automatically cut power to the drive.

#### **4.15.1.6 Transmission and wheel arrangement**

Transmission and wheel arrangement shall conform to the following requirements:

- a) Power transmission *chains* and belts on ride-on toys shall have a shield from, and including, the driving *chain-* or belt-wheel to, and including, the driven *chain-*wheel or belt-wheel at the side(s) where the limb of the child is nearest the *chain* or belt (see Figure 10, side A). There shall also be a shield around the driving *chain-* or belt-wheel on any side where the *chain* or belt is separated from the limb of the child (e.g. by a frame on a bicycle), (see Figure 10, side B).

On ride-on toys where the transmission *chain* or belt can be reached by the rider's hand during use, the transmission shield(s) shall have two sides that comply with the design of side A (see Figure 10).

Drainage holes in the shield(s) are permitted provided that they have a diameter of 5 mm or less.

It shall not be possible to remove the shield without the use of a *tool*.

- b) Wheels directly propelled by pedals shall not have slots or holes with a width greater than 5 mm.

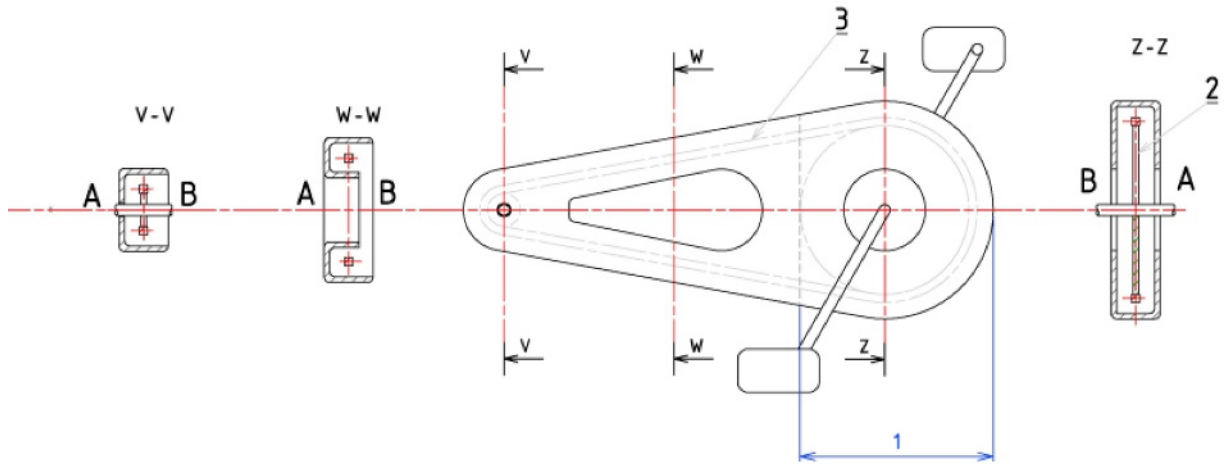

**Key**

- 1 extent of cover on inside face
- 2 front *chain* wheel
- 3 *chain*
- A side where the limb of the child is nearest the *chain*
- B side where the *chain* or belt is separated from the limb of the child

**Figure 10 — Transmission chain shields**

- c) Spaces between the wheels and the body or parts of the body (e.g. mudguards) shall also allow a 12 mm diameter rod to be inserted if they allow a 5 mm diameter rod to be inserted. This requirement does not apply to the friction surfaces of braking mechanisms, toy skateboards or roller skates.
- d) Tricycles provided with an attached handle used for pushing the child, shall be constructed in such a way as to prevent entrapment of the child's feet in the pedals etc. while being pushed (e.g. *free-wheeling mechanism* or foot rests).

**4.15.1.7 Adjustable seat pillar and handlebar stem minimum insertion marks**

Any adjustable seat pillar and adjustable handlebar stem shall have a permanent mark that indicates the minimum insertion depth of the part into the frame of the toy. The minimum insertion mark shall be positioned at a distance not less than two-and-a-half times the diameter of the pillar or stem from the bottom of the pillar - or stem, and there shall be at least one stem diameter's length of contiguous circumferential stem material below the mark (see Figure 11).

The requirement for a minimum insertion mark does not apply if

- there are one or more fixed adjusting positions that all fulfil the dimensional requirements, or
- the minimum insertion depth is defined and limited by the design.

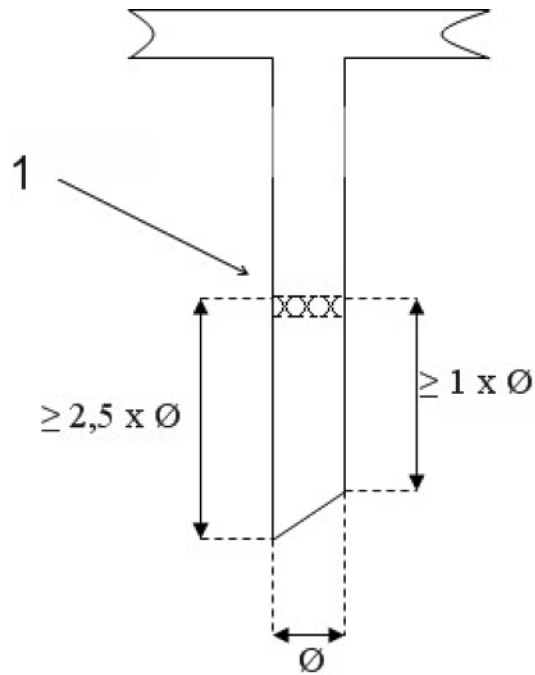

**Key**

1 permanent mark

**Figure 11 — Illustration of dimensional requirement for insertion mark**

**4.15.1.8 Electrically-driven ride-on toys**

Electrically-driven ride-on toys intended for children under 6 years shall be equipped with a seat.

Electrically-driven ride-on toys shall have a maximum design speed which does not exceed the following values when tested according to 8.29 (determination of maximum design speed of electrically-driven ride-on toys):

- toys intended for children over 3 years, but under 6 years: 6 km/h or 8,2 km/h. The higher speed (8,2 km/h) is applicable only if the toy is equipped with a two-position device which limits the maximum design speed to 6 km/h or less in one position, and to 8,2 km/h or less in the other position. The device shall only be intended to be adjusted by an adult by means of a *tool* and shall be in the low speed position at the point of sale;
- toys intended for children of 6 years and over: 16 km/h.

**4.15.2 Toy bicycles (see A.20)**

**4.15.2.1 General**

In addition to relevant requirements in Clause 4, *toy bicycles* shall conform to the requirements in 4.15.2.2 and 4.15.2.3.

**4.15.2.2 Warnings and instructions for use**

*Toy bicycles* shall carry a warning regarding their use in traffic and the need for protective equipment to be worn. They shall also be accompanied by assembly and maintenance instructions, instructions for use and precautions to be taken. The potential dangers of riding a *toy bicycle* shall be brought to the attention of the parents or carers (see 7.15).

*Toy bicycles* that due to their construction, strength, design or other factors are not suitable for use by children of 36 months and over shall carry a warning (see 7.16).

#### **4.15.2.3 Braking requirements**

*Toy bicycles* with a *free-wheeling mechanism* shall be equipped with two independent braking systems, one which operates on the front wheel and one which operates on the rear wheel.

For handbrakes, the brake lever dimension  $d$  measured at the midpoint of the lever as shown in Figure 12 shall not exceed 60 mm. The range of adjustment on an adjustable lever shall permit this dimension to be attained. The lever length shall be 80 mm or more.

The toy shall not move more than 5 cm when tested according to 8.26.2 (brake performance for toy bicycles). This requirement applies also to *toy bicycles* with a *fixed drive*, if they have been equipped with a brake, although not required by this European Standard.

#### **4.15.3 Rocking horses and similar toys (see A.21)**

Rocking horses and similar toys shall conform to the following requirements:

- a) The bow rocker of any bow-mounted rocking horse or other rocking toy shall have a limit to its movement which shall at all times hold the user within the extreme of the bow. Compliance is checked by visual inspection.
- b) The toy shall not tip over when tested according to 8.23.1 (stability, toys intended to bear the mass of a child).
- c) Toys shall not *collapse* so that they do not continue to conform to relevant requirements of this European Standard when tested according to 8.21 (static strength).
- d) Toys that due to their construction, strength, design or other factors are not suitable for use by children of 36 months and over shall carry a warning (see 7.16).
- e) Toys where the intended sitting surface is 600 mm or more above the ground, shall carry a warning (see 7.19).

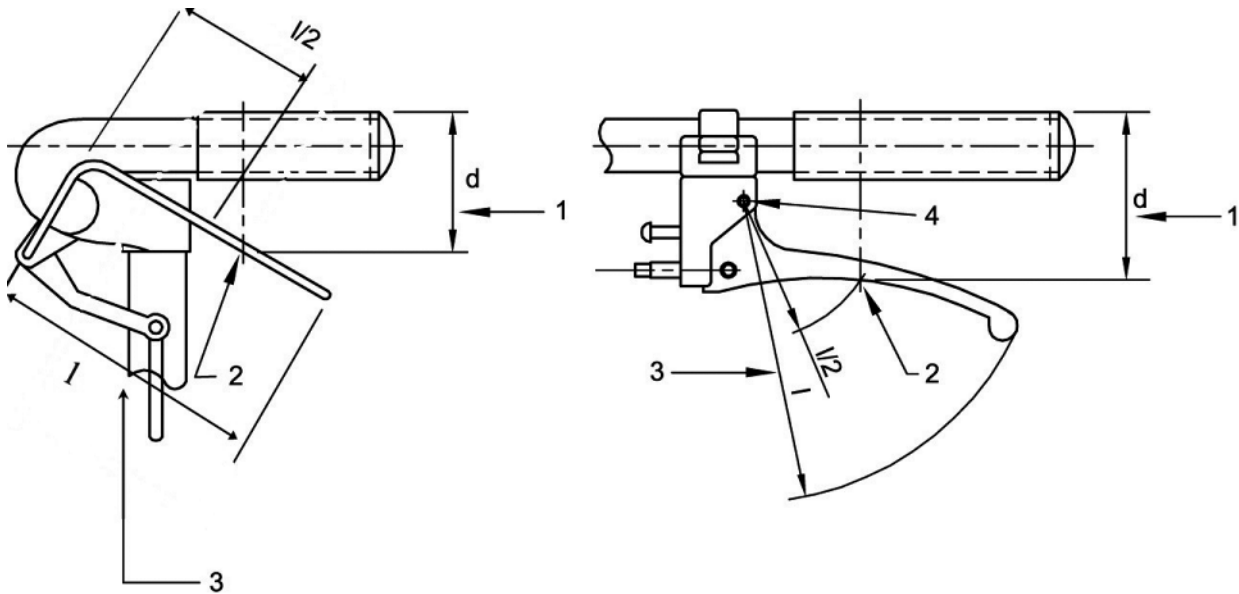

**Key**

- 1 brake lever dimension,  $d$
- 2 midpoint of lever
- 3 lever length,  $l$
- 4 pivot

**Figure 12 — Handbrake lever dimensions**

**4.15.4 Toys not propelled by a child**

Toys not propelled by a child but designed to bear the mass of a child (but not toys covered by EN 71-8) shall conform to the following requirements:

- a) Toys shall not *collapse* so that they do not continue to conform to relevant requirements of this European Standard when tested according to 8.21 (static strength).
- b) Toys shall not tip over when tested according to 8.23.1 (stability, toys intended to bear the mass of a child). This requirement does not apply to toys which for evident reasons cannot be considered as being stable (e.g. big *balls* and *soft-filled* toy animals).
- c) Toys intended to bear the mass of a child shall, when appropriate, be accompanied by instructions for use, assembly and maintenance instructions.
- d) Toys that due to their construction, strength, design or other factors are not suitable for use by children of 36 months and over shall carry a warning (see 7.16).

**4.15.5 Toy scooters (see A.49)**

**4.15.5.1 General**

For the purpose of this European Standard, *toy scooters* are divided into two groups:

- those intended for children with a body mass of 20 kg or less;

- those intended for children with a body mass of 50 kg or less.

*Toy scooters* shall conform to the requirements of 4.15.5.

#### 4.15.5.2 Warnings and instructions for use

*Toy scooters* shall carry a warning regarding the need for protective equipment to be worn and the maximum weight of the user. They shall also be accompanied by assembly and maintenance instructions, instructions for use and precautions to be taken. The potential dangers of riding a *toy scooter* shall be brought to the attention of the parents or carers (see 7.18).

#### 4.15.5.3 Strength

- Toy scooters* shall conform to the requirements in 4.15.1.3 (strength).
- When tested according to 8.27 (strength of toy scooter steering tubes):
  - steering tubes shall not *collapse* so that they do not continue to conform to relevant requirements of this European Standard;
  - steering tubes shall not separate into two or more parts;
  - steering tubes made of metal shall not show visible *cracks*;
  - locking devices shall not fail or disengage.

#### 4.15.5.4 Adjustable and folding steering tubes

- To prevent sudden changes of height, steering tubes with adjustable height shall
  - be adjustable with the use of a *tool*, or
  - have at least one main locking device and one secondary locking device of which at least one shall automatically be engaged when the height is adjusted.

The separation of the steering tube shall not be possible unless intended.

- Steering tubes intended to be folded shall have a locking device on the folding mechanism.
- The space between moving elements capable of injuring fingers, shall also allow a 12 mm rod to be inserted if it allows a 5 mm rod to be inserted.

*Accessible* openings in moving elements capable of shearing a finger shall not allow the insertion of a 5 mm rod.

#### 4.15.5.5 Braking

*Toy scooters* labelled as intended for children with a body mass of 20 kg or less do not require a braking system.

Other *toy scooters* shall have at least one braking system which shall operate on the rear wheel and which shall effectively and smoothly reduce the speed without coming to an abrupt stop.

When tested according to 8.26.3 (brake performance for toy scooters), the force required to hold the *toy scooter* on the inclined plane shall be less than 50 N.

#### 4.15.5.6 Wheel size

The diameter of the front wheel(s) on *toy scooters* shall be 120 mm or greater.

#### 4.15.5.7 Protruding parts

The handles on *toy scooters* shall have an end with a diameter of 40 mm or more.

### 4.16 Heavy immobile toys

Immobile toys with a mass of 4,5 kg or more and intended to rest on the floor but not to bear the mass of a child, shall not tip over when tested according to 8.23.2 (stability, heavy immobile toys).

### 4.17 Projectiles (see A.22)

#### 4.17.1 General

*Projectiles* and *projectile* toys shall conform to the following requirements:

- a) All rigid *projectiles* shall have a tip radius of 2 mm or more.
- b) Resilient materials used as impact surfaces shall not become detached when tested according to 8.4.2.3 (tension test, protective components) unless the resulting elements still conform to the relevant requirements of this European Standard.

If the impact surface is a *suction cup* which passes entirely through template E when tested according to 8.32.1 (small balls and suction cups) the *suction cup* itself shall not become entirely detached when tested according to 8.3 (torque test) and 8.4.2.1 (tension test, general).

- c) Helicopter rotors and single propellers intended to be powered into vertical or nearly vertical free flight by a *spring* mechanism or similar device, shall have a ring around the perimeter in order to reduce the risk of injuries.
- d) *Projectiles* with a *suction cup* as impact area shall have a length of 57 mm or more when measured as indicated in Figure 13, and with their *suction cup* resting on a flat surface without being subjected to any force other than that produced by their own mass. If the *projectile* falls over unless supported, it is permitted to support the *projectile* during the measurement.

The requirement in 4.17.1 d) applies before and after testing according to 8.3 (torque test) and 8.4.2.1 (tension test, general). The requirement in 4.17.1 d) does not apply if the *suction cup* does not pass entirely through template E when tested according to 8.32.1 (small balls and suction cups).

The requirement in 4.17.1 d) applies both to *projectiles* where the *suction cup* is an integral part of the *projectile* and to *projectiles* where the *suction cup* is attached to the rest of the *projectile*.

Dimensions in millimetres

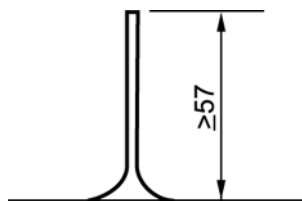

Figure 13 — Measurement of length of projectiles with suction cup



#### 4.17.2 Projectile toys without stored energy

*Projectile toys without stored energy* shall conform to the following requirements:

*Projectiles* in the form of darts shall have blunted points or points that are protected by a resilient material (e.g. rubber) having an impact area of 3 cm<sup>2</sup> or more. Points shall not be made of metal. However, darts fitted with magnetic metal discs are permitted if the disc has an area of 3 cm<sup>2</sup> or more.

#### 4.17.3 Projectile toys with stored energy

*Projectiles* propelled from a discharge mechanism shall conform to the following requirements:

- a) The maximum kinetic energy of *projectiles*, when tested according to 8.24.1 (kinetic energy of projectiles) shall not exceed:
  - 1) 0,08 J for rigid *projectiles* without resilient impact surfaces;
  - 2) 0,5 J for resilient *projectiles* or *projectiles* with resilient impact surfaces (e.g. rubber).
- b) For *projectiles* in the form of arrows whose maximum kinetic energy exceeds 0,08 J, their impact surfaces shall be protected by a resilient material (e.g. rubber). The maximum kinetic energy per unit area of the resilient impact surface shall not exceed 0,16 J/cm<sup>2</sup> when tested according to 8.24.1 (kinetic energy of projectiles).
- c) If a discharge mechanism is able to discharge an object other than that provided with the toy, the potential danger shall be drawn to the attention of the user (see 7.7.1).

If a toy is capable of discharging a *projectile* with a kinetic energy greater than 0,08 J, the potential danger shall be drawn to the attention of the user by a warning (see 7.7.2).

NOTE In order to reduce the risk of eye injuries, manufacturers are strongly recommended to design toys so that they are not able to discharge missiles other than those provided with the toy.

#### 4.17.4 Bows and arrows

For the purpose of this European Standard, bows offered for sale with arrows are to be considered as toys.

Arrows discharged from a bow shall comply with the following requirements:

- a) Points of arrows shall not be made of metal; however, points fitted with magnetic metal discs are permitted if the disc has an area of 3 cm<sup>2</sup> or more.
- b) The maximum kinetic energy of arrows discharged from a bow shall not exceed the values given in 4.17.3 a) when tested according to 8.24.2 (kinetic energy of bows and arrows).
- c) Arrows whose maximum kinetic energy exceeds 0,08 J, when tested according to 8.24.2, shall conform to 4.17.3 b). The potential danger of discharging such arrows shall be drawn to the attention of the user by a warning (see 7.7.2).

#### 4.18 Aquatic toys and inflatable toys (see A.23)

*Aquatic toys*, and inflatable toys provided with air-inflation inlets with stoppers, shall conform to the following requirements:

- a) Air-inflation inlets on *aquatic toys* shall have stoppers and all air-inflation inlets with stoppers on *aquatic toys* and inflatable toys shall have the stoppers permanently attached to the toy. The stopper, or any part

of it, if detached when tested according to 8.3 (torque test), and 8.4.2.1 (tension test, general) shall not fit entirely in the cylinder when tested according to 8.2 (small parts cylinder).

- b) For inflatable *aquatic toys*, the stopper shall be capable of being pushed into the toy so that it does not protrude more than 5 mm from the surface of the toy when inflated.
- c) The potential danger of using *aquatic toys* shall be drawn to the attention of the user by a warning (see 7.4).

In addition, inflatable aquatic ride-on toys with a maximum dimension larger than 1,2 meters (e.g. large inflatable animals) measured on the uninflated toy, shall fulfil the applicable requirements for floating leisure articles, Class A 2 devices in EN 15649-3.

#### **4.19 Percussion caps specifically designed for use in toys and toys using percussion caps (see A.24)**

Assuming reasonably foreseeable use, percussions caps specifically designed for use in toys shall not produce debris which could cause eye injuries, flames or glowing residues.

The *packaging* of percussion caps shall carry a warning regarding their use (see 7.13).

Toys intended to be used with percussion caps shall carry an indication regarding which make and model of percussion caps they can be safely used with, and a warning regarding their use (see 7.14). The warning may alternatively be placed on the *packaging* (see 7.14).



#### **4.20 Acoustics (see A.25)**

##### **4.20.1 Exposure categories for time-averaged sound pressure levels**

To take into account the fact that the effective time of sound emission from a toy under use can vary considerably, toys designed to emit sound are divided into 3 exposure categories. The toys mentioned under each category refer to the traditional versions of these toys. Toys which are not of traditional design may belong to another exposure category. For toys that do not fit clearly into a specific category, the nearest strictest (i.e. the lowest numbered) category should be used:

- Exposure category 1:
  - Toys emitting sound during time periods typically longer than 30 s after each initiation;
  - *Close-to-the-ear toys* emitting sound during time periods typically longer than 30 s after each initiation;
  - Toys using headphones or earphones;
  - Other toys emitting sound typically during more than 1/3 of the playing time.
- Exposure category 2:
  - Toys emitting sound during time periods typically shorter than 30 s but longer than 5 s after each initiation;
  - *Close-to-the-ear toys* that, while emitting sound, are held close to the ear during time periods typically shorter than 30 s but longer than 5s;

- Rattles and squeeze toys;
  - *Wind toys* which are imitations of musical instruments;
  - Other toys emitting sound typically during less than 1/3 and more than 1/10 of the playing time.
- Exposure category 3:
- Toys emitting sound during time periods typically shorter than 5 s after each initiation;
  - Toys for which maintaining the sound output requires significant physical effort;
  - *Close-to-the-ear toys* that, while emitting sound, are held close to the ear during time periods typically shorter than 5 s;
  - Cap-firing toys;
  - *Wind toys* such as whistles;
  - Other toys emitting sound typically during less than 1/10 of the playing time.

NOTE An example of a toy for which maintaining the sound output requires a significant physical effort is an electronic toy gun firing one shot per trigger-initiation. Although a single shot would require little effort a great number of single shots at high frequency would require a significant effort if repeated during several minutes.

#### 4.20.2 Emission sound pressure level limits

##### 4.20.2.1 General

Toys shall be assessed against the sub-clause most relevant for their sound mode or sound function. Toys with more than one sound function may be assessed against multiple sub-clauses. Toys or sound functions of toys that do not clearly fit within any of the clauses shall be assessed as either *hand-held toys* or *table-top or floor toys*, whichever is the more appropriate.

When tested according to 8.28 (determination of emission sound pressure levels), toys which are clearly designed to emit sound shall conform to the requirements in the following sub-clauses of 4.20.2:

##### 4.20.2.2 Close-to-the-ear toys

The A-weighted *time averaged emission sound pressure level*,  $L_{pA}$ , produced when tested according to 8.28.2.1 at 50 cm by *close-to-the-ear toys* shall not exceed 60 dB for exposure category 1 toys, 65 dB for exposure category 2 toys and 70 dB for exposure category 3 toys. The C-weighted *peak emission sound pressure level*,  $L_{pCpeak}$ , produced when tested according to 8.28.2.1 at 50 cm shall not exceed 110 dB.

##### 4.20.2.3 Table-top or floor toys

The A-weighted *time-averaged emission sound pressure level*,  $L_{pA}$ , produced when tested according to 8.28.2.2 at 50 cm by *table-top or floor toys* shall not exceed 80 dB for exposure category 1 toys, 85 dB for exposure category 2 toys and 90 dB for exposure category 3 toys. The C-weighted *peak emission sound pressure level*,  $L_{pCpeak}$ , produced when tested according to 8.28.2.2 at 50 cm shall not exceed 110 dB.

##### 4.20.2.4 Hand-held toys

The A-weighted *time-averaged emission sound pressure level*,  $L_{pA}$ , produced when tested according to 8.28.2.3 at 50 cm by *hand-held toys* shall not exceed 80 dB for exposure category 1 toys, 85 dB for exposure category 2 toys and 90 dB for exposure category 3 toys. The C-weighted *peak emission sound pressure level*,  $L_{pCpeak}$ , produced when tested according to 8.28.2.3 at 50 cm shall not exceed 110 dB.

#### **4.20.2.5 Toys using headphones or earphones**

The A-weighted *time-averaged emission sound pressure level*,  $L_{pA}$ , produced by toys using headphones or earphones, when tested according to 8.28.2.4, measured in an ear simulator and after correction to an equivalent free field sound pressure level, shall not exceed 85 dB. The C-weighted *peak emission sound pressure level*,  $L_{pCpeak}$ , produced when tested according to 8.28.2.4, measured in an ear simulator and after correction to an equivalent free field sound pressure level shall not exceed 135 dB.

#### **4.20.2.6 Rattles**

The A-weighted *time-averaged emission sound pressure level*,  $L_{pA}$ , produced when tested according to 8.28.2.5 at 50 cm by *rattles* shall not exceed 85 dB. The C-weighted *peak emission sound pressure level*,  $L_{pCpeak}$ , produced when tested according to 8.28.2.5 at 50 cm shall not exceed 110 dB.

#### **4.20.2.7 Squeeze toys**

The A-Weighted *time-averaged emission sound pressure level*,  $L_{pA}$ , produced when tested according to 8.28.2.6 at 50 cm by *squeeze toys* shall not exceed 85 dB. The C-weighted *peak emission sound pressure level*,  $L_{pCpeak}$ , produced when tested according to 8.28.2.6 at 50 cm shall not exceed 110 dB.

#### **4.20.2.8 Pull-along or push toys**

The A-Weighted *maximum emission sound pressure level*, measured using a meter with time-weighting F,  $L_{AFmax}$ , produced when tested according to 8.28.2.7 at 50 cm by *pull-along or push toys* clearly designed to emit sound only as a result of movement imparted on the toy, shall not exceed 80 dB for exposure category 1 toys, 85 dB for exposure category 2 toys, and 90 dB for exposure category 3 toys. The C-weighted *peak emission sound pressure level*,  $L_{pCpeak}$ , produced when tested according to 8.28.2.7 at 50 cm shall not exceed 110 dB.

NOTE Examples of *pull-along or push toys* that emit sound only as a result of movement imparted on the toy, include toys making intentional mechanically excited sound when the axles/wheels are rotating. *Pull-along or push toys* that produce sound which is not dependant on the energy imparted by the user, for example electronic sound, are instead tested as *hand-held toys* or *table-top or floor toys* (see 8.28.1.3).

#### **4.20.2.9 Percussion toys**

The A-weighted *time-averaged emission sound pressure level*,  $L_{pA}$ , produced when tested according to 8.28.2.8 at 50 cm by *percussion toys* shall not exceed 85 dB. The C-weighted *peak emission sound pressure level*,  $L_{pCpeak}$ , produced when tested according to 8.28.2.8 at 50 cm shall not exceed 130 dB.

If the C-weighted *peak emission sound pressure level*,  $L_{pCpeak}$ , produced by a *percussion toy* exceeds 110 dB, the potential danger to hearing shall be drawn to the attention of the user by a warning (see 7.14).

#### **4.20.2.10 Wind toys**

The A-weighted *time-averaged emission sound pressure level*,  $L_{pA}$ , produced when tested according to 8.28.2.9 at 50 cm by *wind toys* shall not exceed 85 dB for exposure category 2 toys and 90 dB for exposure category 3 toys. The C-weighted *peak emission sound pressure level*,  $L_{pCpeak}$ , produced when tested according to 8.28.2.9 at 50 cm shall not exceed 110 dB.

#### **4.20.2.11 Cap-firing toys**

The A-weighted *time-averaged emission sound pressure level*,  $L_{pA}$ , produced when tested according to 8.28.2.10 at 50 cm by *cap-firing toys* shall not exceed 90 dB. The C-weighted *peak emission sound pressure level*,  $L_{pCpeak}$ , produced when tested according to 8.28.2.10 at 50 cm shall not exceed 125 dB.

Where the C-weighted *peak emission sound pressure level*,  $L_{pC\ peak}$ , produced by a *cap-firing toy* exceeds 110 dB, the potential danger to hearing shall be drawn to the attention of the user by a warning (see 7.14).

#### **4.20.2.12 Voice toys**

The A-weighted *time-averaged emission sound pressure level*,  $L_{pA}$ , produced when tested according to 8.28.2.11 at 50 cm by *voice toys* shall not exceed 80 dB for exposure category 1 toys, 85 dB for exposure category 2 toys and 90 dB for exposure category 3 toys. The C-weighted *peak emission sound pressure level*,  $L_{pC\ peak}$ , produced when tested according to 8.28.2.11 at 50 cm shall not exceed 110 dB.

An overview of the requirements is given in Table 1 and 2.

Table 1 - A-weighted time-averaged emission sound pressure level limit,  $L_{pA}$ , assumed use distance and measurement distance

Toy Type	Exposure category (number)	Assumed use distance (cm)	Measurement distance (cm)	Limit at the measurement distance (dB)
Sub-clause 4.20.2.2 Close-to-the-ear toys	1	2,5	50	60
	2	2,5	50	65
	3	2,5	50	70
Sub-clause 4.20.2.3 Table-top or floor toys	1	25	50	80
	2	25	50	85
	3	25	50	90
Sub-clause 4.20.2.4 Hand-held toys	1	25	50	80
	2	25	50	85
	3	25	50	90
Sub-clause 4.20.2.5 Toys using headphones or earphones	1	<sup>a</sup>	<sup>a</sup>	85 <sup>a</sup>
Sub-clause 4.20.2.6 Rattles	2	25	50	85
Sub-clause 4.20.2.7 Squeeze toys	2	25	50	85
Sub-clause 4.20.2.8 Pull-along or push toys	1	25	50	80 <sup>b</sup>
	2	25	50	85 <sup>b</sup>
	3	25	50	90 <sup>b</sup>
Sub-clause 4.20.2.9 Percussion toys	2	25	50	85
Sub-clause 4.20.2.10 Wind toys	2	25	50	85
	3	25	50	90
Sub-clause 4.20.2.11 Cap-firing toys	3	25	50	90
Sub-clause 4.20.2.12 voice toys	1	25	50	80
	2	25	50	85
	3	25	50	90
<sup>a</sup> Measured using an ear simulator device and converted to a free field equivalent.				
<sup>b</sup> This limit value refers to the A-weighted <i>maximum emission sound pressure level</i> using time-weighting F, $L_{pAFmax}$ .				

Table 2 - C-weighted emission peak sound pressure level limit, worst case use distance and measurement distance

Toy Type	Worst case use distance (cm)	Measurement distance (cm)	$L_{pCpeak}$ at measurement distance (dB)
Sub-clause 4.20.2.2 Close-to-the-ear toys	2,5	50	110
Sub-clause 4.20.2.3 Table-top or floor toys	2,5	50	110
Sub-clause 4.20.2.4 Hand-held toys	2,5	50	110
Sub-clause 4.20.2.5 Toys using headphones or earphones	<sup>a</sup>	<sup>a</sup>	135 <sup>a</sup>
Sub-clause 4.20.2.6 Rattles	2,5	50	110
Sub-clause 4.20.2.7 Squeeze toys	2,5	50	110
Sub-clause 4.20.2.8 Pull-along or push toys	2,5	50	110
Sub-clause 4.20.2.9 Percussion toys	25	50	130
Sub-clause 4.20.2.10 Wind toys	2,5	50	110
Sub-clause 4.20.2.11 Cap-firing toys	2,5	50	125
Sub-clause 4.20.2.12 voice toys	2,5	50	110

<sup>a</sup> Measured using an ear simulator device and converted to a free field equivalent.



#### 4.21 Toys containing a non-electrical heat source

The following requirements do not apply to burners and similar items in chemistry sets and experimental kits and similar items.

- a) Toys containing a heat source shall not ignite when used at the maximum input when tested according to 8.30 (measurement of temperature rises).
- b) The temperature rise of all handles, knobs and similar parts which are likely to be touched by hand, shall not exceed the following values when tested according to 8.30 (measurement of temperature rises):
  - parts of metal 25 K;
  - parts of glass or porcelain 30 K;

— parts of plastics or wood 35 K.

c) The temperature rise of other *accessible* parts of the toy shall not exceed the following values when tested according to 8.30 (measurement of temperature rises):

— parts of metal 45 K;

— parts of glass or porcelain 50 K;

— parts of other materials 55 K.

NOTE Requirements for toys containing an electrical heat source are given in EN 62115.

#### **4.22 Small balls (see 5.10 and A.48)**

This requirement does not apply to *soft-filled balls*.

Any *ball* that passes entirely through template E when tested according to 8.32.1 (small balls and suction cups) is considered to be a small *ball*.

Any *ball* attached to a toy by a *cord*, such that the *ball* is suspended freely, is considered to be a small *ball* if it passes through the base of template E such that the distance A is greater than 30 mm when tested according to 8.32.2 (small balls attached to a toy by a cord).

Toys that are small *balls* or contain *removable* small *balls* or contain small *balls* that become detached when tested according to 8.3 (torque test), 8.4.2.1 (tension test, general), 8.5 (drop test), 8.7 (impact test) and 8.8 (compression test) shall carry a warning (see 7.2). For *large and bulky toys* the drop test is substituted by 8.6 (tip over test).

#### **4.23 Magnets (see A.51)**

##### **4.23.1 General**

The requirements in 4.23.2 do not apply to *functional magnets in electrical or electronic components of toys*.

The requirement in 4.23.3 does not apply to *magnetic/electrical experimental sets* in which all magnets have a magnetic flux index less than  $50 \text{ kG}^2\text{mm}^2$  ( $0,5 \text{ T}^2\text{mm}^2$ ) when tested according to 8.35 (magnetic flux index), or do not fit entirely in the cylinder when tested according to 8.2 (small parts cylinder).

##### **4.23.2 Toys other than magnetic/electrical experimental sets intended for children over 8 years**

a) Any loose as-received magnet(s) and *magnetic component(s)* shall either have a magnetic flux index less than  $50 \text{ kG}^2\text{mm}^2$  ( $0,5 \text{ T}^2\text{mm}^2$ ) when tested according to 8.35 (magnetic flux index), or shall not fit entirely in the cylinder when tested according to 8.2 (small parts cylinder).

b) Any magnet(s) and *magnetic component(s)* that become(s) released from a toy, or from a loose as-received *magnetic component*, when tested according to 8.3 (torque test), 8.4.2.1 (tension test, general), 8.4.2.2 a) (tension test, seams and materials), 8.5 (drop test), 8.7 (impact test), 8.8 (compression test), and finally, for magnets that are *accessible* but not grippable (as specified in 8.4.2.1), 8.34 (tension test for magnets), shall either have a magnetic flux index less than  $50 \text{ kG}^2\text{mm}^2$  ( $0,5 \text{ T}^2\text{mm}^2$ ) when tested according to 8.35 (magnetic flux index), or shall not fit entirely in the cylinder when tested according to 8.2 (small parts cylinder). For *large and bulky toys*, the drop test is substituted by 8.6 (tip over test).

NOTE An example of a magnet that is *accessible* but not grippable is a magnet that is recessed.



- c) Wooden toys, toys intended to be used in water, and mouth-actuated toys shall be tested according to 8.9 (soaking test) before being tested according to 4.23.2 b) above.

#### 4.23.3 Magnetic/electrical experimental sets intended for children over 8 years

*Magnetic/electrical experimental sets* intended for children over 8 years shall carry a warning (see 7.20).

This warning is not required for *magnetic/electrical experimental sets* in which all magnets have a magnetic flux index less than  $50 \text{ kG}^2\text{mm}^2$  ( $0,5 \text{ T}^2\text{mm}^2$ ) when tested according to 8.35 (magnetic flux index), or do not fit entirely in the cylinder when tested according to 8.2 (small parts cylinder).

#### 4.24 Yo-yo balls (see A.52)

The initial length  $l_0$  of the *yo-yo ball* tether, measured as described in 8.37.1 shall not be greater than 370 mm.

The ratio of the mass  $m$  (in grams) to the elastic constant  $k$  of the *yo-yo ball*, measured as described in 8.37.2 shall be less than 2,2 (see Equation 1):

$$\frac{m}{k} < 2,2 \quad (1)$$

where

$m$  is the total mass of the *ball* and the tether made of *elastic material*;

$k$  is the elastic constant of the *yo-yo ball* as measured in 8.37.2.

#### 4.25 Toys attached to food (see A.55)

Toys attached to food shall conform to the following requirements:

Prior to testing the toy to sub-clauses a) and b), the food shall be removed, in such a manner that the toy is not damaged.

- a) Toys and *removable components* of toys that are directly attached to a food product in such a way that the food product does not need to be consumed in order to get direct access to any part of the toy, shall not fit entirely in the cylinder when tested according to 8.2 (small parts cylinder) or, if the toy or *removable component* of the toy is a *ball*, pass entirely through template E when tested according to 8.32.1 (small balls and suction cups).
- b) When tested according to 8.3 (torque test), 8.4.2.1 (tension test, general), 8.5 (drop test), 8.7 (impact test) and 8.8 (compression test), toys subject to the requirements of 4.25 a) shall not produce any parts which, whatever their position, fit entirely in the cylinder when tested according to 8.2 (small parts cylinder) or any *ball* which passes entirely through template E when tested according to 8.32.1 (small balls and suction cups).

NOTE Directive 2009/48/EC includes additional specific safety requirements for toys that are firmly attached to, contained in or co-mingled with food. According to the directive, toys firmly attached to a food product in such a way that the food product needs to be consumed in order to get direct access to the toy (i.e. no part of the toy is *accessible* before consuming the food), are prohibited.

Furthermore, the Directive states that toys contained within food or co-mingled with food must have their own *packaging*. According to the Directive, this *packaging*, as it is supplied, in addition to other requirements must not fit entirely in the small parts cylinder. Furthermore, the outer food *packaging* must, according to the Directive, carry the following warning: "Warning. Toy inside. Adult supervision recommended." This information is not exhaustive and Directive 2009/48/EC and the associated guidance documents should be consulted for further details.

## 5 Toys intended for children under 36 months

Toys intended for children under 36 months shall in addition to relevant requirements of Clause 4 conform to the following requirements, where applicable.

NOTE According to Directive 2009/48/EC the following safety requirements apply regarding cleaning and washing: "A toy intended for use by children under 36 months must be designed and manufactured in such a way that it can be cleaned. A textile toy must, to this end, be washable, except if it contains a mechanism that may be damaged if soaked washed. The toy must fulfil the safety requirements also after having been cleaned in accordance with this point and the manufacturer's instructions." The manufacturer should, if applicable, provide instructions on how the toy has to be cleaned. This information is not exhaustive and Directive 2009/48/EC and the associated guidance documents should be consulted for further details.

### 5.1 General requirements (see A.26)

The requirements in 5.1 do not apply to the following:

- $\text{A}_3$  paper, fabric (including felt and elastic fabric), yarn, string and fuzz;  $\text{A}_3$
- crayons, chalks, pencils and similar writing and drawing implements without *removable components*;
- balloons;
- modelling clay and similar products.

However, tightly packed stuffed components made of fabric and/or yarn are not excluded from the general requirements of 5.1.

The general requirements are as follows:

- a) Toys and *removable components* of toys shall not, whatever their position, fit entirely in the cylinder when tested according to 8.2 (small parts cylinder) (see A.26).

$\text{A}_3$  In addition, attached *paperboard* components of toys, that detach after the test specified in 8.4.2.1 (tension test, general) shall not fit entirely in the small parts cylinder when tested according to 8.2 (small parts cylinder).

The requirement in 5.1 b) does not apply to *paperboard* toys or to *paperboard* parts of toys.  $\text{A}_3$

- b) When tested according to 8.3 (torque test), 8.4.2.1 (tension test, general), 8.5 (drop test), 8.7 (impact test) and 8.8 (compression test), toys shall not produce any parts which, whatever their position, fit entirely in the cylinder when tested according to 8.2 (small parts cylinder), or exhibit *accessible* hazardous sharp edges (see 8.11, sharpness of edges), or *accessible* hazardous sharp points (see 8.12, sharpness of points), and toys with *springs* shall continue to conform to the requirements in 4.10.4 (springs). Toys that contain magnets or *magnetic components* shall also fulfil the requirements given in 4.23.2 b) and c) with the addition that release of magnets or *magnetic components* with a magnetic flux index less than  $50 \text{ kG}^2\text{mm}^2$  ( $0,5 \text{ T}^2\text{mm}^2$ ) is not permitted if the released magnets fit entirely in the cylinder when tested according to 8.2 (small parts cylinder).
- c)  $\text{A}_3$  Metal points and wires with a cross section of 2 mm or less that do not necessarily present a sharp point according to 8.12 (sharpness of points) are considered to be potentially hazardous sharp points. They shall therefore be assessed to determine whether they present an unreasonable risk of injury taking into account the foreseeable use of the toy (see also A.9).
- d) *Large and bulky toys* shall be tested according to 5.1 b) above with the exclusion of 8.5 (drop test) and with the inclusion of a test according to 8.6 (tip over test).

Ⓐ<sub>3</sub> The requirement in 5.1 e) does not apply to *large and bulky toys* and to toys and components of toys made of *paperboard*. Ⓐ<sub>3</sub>

- e) Glued wooden toys and toys with glued-on plastic decals shall be tested according to 8.9 (soaking test) before being tested according to 5.1 b). Flakes of paint that have come loose from painted toys are exempt from being tested according to 8.2 (small parts cylinder). Thick surface coatings such as varnish are not exempt.
- f) The casing of toys intended for children too young to sit up unaided, shall not *crack* when tested according to 5.1 b). A *crack* may be accepted if it clearly does not create a hazard (see also A.26).
- g) For foam toys and toys containing *accessible* foam components, clamps and test fixtures used to perform the tests shall not damage the toy or component such as to affect the results when tested according to 8.3 (torque test) and 8.4.2.1 (tension test, general).

## 5.2 Soft-filled toys and soft-filled parts of a toy (see A.27)

- a) *Fillings* shall not contain any hard and sharp contaminants such as pieces of metal, nails, needles and splinters.
- b) *Soft-filled toys* and *soft-filled* parts of a toy containing small parts (e.g. rattling components, bells, shredded foam) or with *filling* from which pieces can be bitten or torn thereby producing small parts, which fit entirely in the cylinder when tested according to 8.2 (small parts cylinder), shall have at least one covering so that, after being tested according to 8.4.2.2 a) (tension test, seams and materials), it shall not be possible to insert the front part of probe A, as specified in 8.10 (accessibility of part or component), through any one opening in the seam or cover material. An opening may be accepted if it clearly does not create a hazard.

NOTE *Filling* from which pieces can be bitten or torn off include, for example, plastic foam but exclude *paper*, fabric, elastics, yarn, strings and *fuzz*.

- c) *Soft-filled toys* and *soft-filled* parts of a toy, containing fibrous *filling* material shall have at least one covering such that, after being tested according to 8.4.2.2 b) (tension test, seams and materials), it shall not be possible to insert the front part of a 12 mm diameter rod with a fully radiused end through any one opening in the seam or cover material by more than 6 mm.

## 5.3 Plastic sheeting (see A.28)

*Plastic sheeting* which becomes detached when tested according to 8.25.2 (plastic sheeting, adhesion) and 8.4.2.1 (tension test, general) and has an area greater than 100 mm × 100 mm, shall have an average thickness of 0,038 mm or more when tested according to 8.25.1 (plastic sheeting, thickness).

## 5.4 Cords, chains and electrical cables in toys (see A.29)

The requirements in this clause do not apply to ropes and *chains* that are covered by the diameter requirements of EN 71-8 (e.g. climbing and swinging ropes).

The requirements in this clause do not apply to *straps* intended to be worn fully or partially around the neck (see 5.14), to *straps* in toy safety harnesses, toy-backpack shoulder *straps* or to toy bag/bucket/box handles.

Requirements from 5.4 a) to 5.4 e) do not apply to:

- toys intended to be strung across a cradle, cot or perambulator. However, any elements hanging down from such toys, where the elements are intended to be within the reach of children, shall fulfil the applicable requirements in 5.4 a) to 5.4 e);

- toys intended to be attached to a cradle, cot or perambulator, where the *cords* of such toys are intended to be out of reach of the children.
- a) *Cords* connected to a self-retraction mechanism and *cords* in pull-along toys shall have an average cross-sectional dimension of 1,5 mm or more when measured according to 8.20 (*cords* cross-sectional dimension).
- b) *Cords* and *chains* that can form a *tangled loop* or a *noose* shall either:
  - have a length not exceeding 220 mm (for toys intended for children under 18 months) or have a length not exceeding 300 mm (for other toys) when measured according to 8.40 (length of *cords*, *chains* and electrical cables), or
  - separate into parts with a length not exceeding 220 mm (for toys intended for children under 18 months) or with a length not exceeding 300 mm (for other toys) when tested according to 8.38 (breakaway feature separation test). It shall be possible to join the parts after they have been separated without altering the characteristics of the joints (see Figure 14). The length of the separated parts shall be measured according to 8.40 (length of *cords*, *chains* and electrical cables).

Toys intended for children of 18 months and over, but under 36 months, and having *cords* or *chains* with a length exceeding 220 mm (which do not separate into one or more parts with a length not exceeding 220 mm) that can form a *tangled loop* or a *noose*, shall be accompanied by a warning (see 7.22), visible at the point of sale, on the toy itself or on its *packaging*.

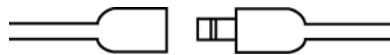

**Figure 14 — Example of a joint on cords**

- c) *Fixed loops* of *cords* or *chains* shall either:
  - have a perimeter not exceeding 380 mm when measured according to 8.36.2.1 (*cords* and *chains* with a single fixing point or with fixing points less than 94 mm apart), or a distance “d” not exceeding 96 mm when measured according to 8.36.2.2 (*cords* and *chains* fixed to a toy at points of 94 mm or more apart), or
  - separate into parts with a length not exceeding 220 mm (for toys intended for children under 18 months) or with a length not exceeding 300 mm (for other toys) when tested according to 8.38 (breakaway feature separation test). The length of the separated parts shall be measured according to 8.40 (length of *cords*, *chains* and electrical cables).

Toys intended for children of 18 months and over, but under 36 months, having a *fixed loop* that separates into one or more parts with a length exceeding 220 mm, shall be accompanied by a warning (see 7.22), visible in the point of sale, on the toy itself or on its *packaging*.

Where the distance between fixing points of *cords* and *chains* can change during play due to the flexibility of the toy (e.g. *cords* on *soft filled toys* or on textile toys without rigid parts) the perimeter shall be determined according to 8.36.2.1 regardless of the at-rest distance between the fixing points.

- d) The perimeter of *nooses*:
  - shall not exceed 380 mm when measured according to 8.36.2.1, or
  - the distance *d* shall not exceed 96 mm when measured according to 8.36.2.2.

- e) The force of self-retraction mechanisms for *cords* in toys shall not retract the *cord* under any of the testing-conditions specified in 8.39 (self-retracting cords).
- f) Toys with *cords* intended to be strung across a cradle, cot or perambulator shall carry a warning (see 7.11). This requirement applies also to toys with *cords* intended to be attached to a cradle, cot or perambulator where the *cords* of such toys are intended to be out of reach of the children if they have *cords* longer than 220 mm that can form a *tangled loop* or a *noose*.
- g) *Cords* and *chains* with a free end (i.e. with no attachments) on toys (excluding pull-along toys) intended for children under 18 months shall have a free length not exceeding 300 mm when measured according to 8.40 (length of cords, chains and electrical cables).
- Toys (excluding pull-along toys) intended for children over 18 months, but under 36 months, having *cords* or *chains* with a free end and a free length exceeding 300 mm, shall carry a warning (see 7.22).
- h) *Cords* and *chains* with a free end (i.e. with no attachments) on pull-along toys intended for children under 36 months shall have a free length not exceeding 800 mm when measured according to 8.40 (length of cords, chains and electrical cables).
- i) Toys with *electrical cables* longer than 300 mm when measured according to 8.40 (length of cords chains and electrical cables) shall carry a warning (see 7.21).

### 5.5 Liquid-filled toys (see A.30)

Upon completion of relevant tests according to Clauses 4 and 5, toys with non-*accessible* liquid shall be tested according to 8.15 (leakage of liquid-filled toys) and there shall be no leakage of the contents nor any splitting or *cracking* which could lead to leakage of the contents.

Liquid-filled *teethers* shall carry a warning that the *teether* is not to be placed in a freezer compartment (see 7.12).

### 5.6 Speed limitation of electrically-driven ride-on toys

Electrically-driven ride-on toys shall have a maximum design speed of 6 km/h or less when tested according to 8.29 (determination of maximum design speed of electrically-driven ride-on toys).

### 5.7 Glass and porcelain (see 4.5 and A.6)

*Accessible* glass and *accessible* porcelain shall not be used in the construction of toys intended for children under 36 months.

### 5.8 Shape and size of certain toys (see A.31)

The requirements in 5.8 a) and b) do not apply to *soft-filled* parts of a toy or parts of fabric. They do not apply to rigid elements having a major dimension equal to 30 mm or less.

The shape and size of toys intended for children who are too young to sit up unaided, shall conform to the requirements in 5.8 a) and b), as supplied.

Toys that are clearly marketed for such children include, but are not limited to:

- *rattle*-shaped toys and *squeeze toys* with or without noise making features;
- *teethers*, toys or components intended to be chewed on;
- hand-held activity toys;

- books and building blocks covered by textile or vinyl;
  - *removable components* of toys intended to be strung across a crib, playpen or perambulator;
  - *removable components* of baby gyms;
  - legs of baby gyms. The requirements in 5.8 a) and b) apply regardless of the mass of the baby gym.
- a) For such toys having a mass of 0,5 kg or less, no part of the toy shall protrude past the base of template A when tested according to 8.16 (geometric shape of certain toys).
- b) For such toys with nearly spherical, hemispherical or circular flared ends having a mass of 0,5 kg or less, no part of the toy shall protrude past the base of template B when tested according to 8.16 (geometric shape of certain toys).

### **5.9 Toys comprising monofilament fibres (see A.32)**

Toys comprising monofilament fibres of straightened length greater than 50 mm and attached to a fabric base shall carry a warning (see 7.17).

### **5.10 Small balls (see also 4.22 and A.48)**

This requirement does not apply to *soft-filled balls*.

Any *ball* that passes entirely through template E when tested according to 8.32.1 (small balls and suction cups) is considered to be a small *ball*.

Any *ball* attached to a toy by a *cord*, such that the *ball* is suspended freely, is considered to be a small *ball* if it passes through the base of template E such that the distance A is greater than 30 mm when tested according to 8.32.2 (small balls attached to a toy by a cord).

- a) Toys shall not be small *balls* or contain removable small *balls*.
- b) Small *balls* shall not become detached when tested according to 8.3 (torque test), 8.4.2.1 (tension test, general), 8.5 (drop test), 8.7 (impact test) and 8.8 (compression test), and for glued wooden toys 8.9 (soaking test). For *large and bulky toys*, the drop test is substituted by 8.6 (tip over test).

NOTE See also the requirement in 6 c) regarding *packaging* which is a small *ball*.

### **5.11 Play figures**

This requirement does not apply to *soft-filled toys*.

Play figures having:

- a) a rounded, spherical or hemispherical end with tapered neck attached to a cylindrical shape without appendages, and
- b) an overall length not exceeding 64 mm (see examples in Figure 15),

shall be designed so that when tested according to 8.33 (test for play figures), the rounded end shall not protrude past the base of template B. The requirement applies to figures with added or moulded features such as hats or hair which retain the rounded shape of the end.

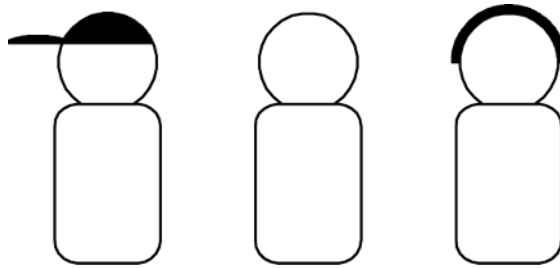

Figure 15 — Examples of play figures

### 5.12 Hemispheric-shaped toys (see A.50)

These requirements apply to cup-shaped toys, bowl-shaped toys and one half of egg-shaped toys having a nearly round, oval or elliptical opening with the minor and major inner dimensions between 64 mm and 102 mm, a volume of less than 177 ml and a depth greater than 13 mm.

The following toys are exempt from these requirements:

- containers that need to be airtight so the contents can maintain their functional integrity (e.g. modelling clay containers);
- components of larger products (e.g. bowl-shaped smoke stack that is permanently attached to a toy train or a swimming pool that is moulded into a larger toy playscape) that do not become detached when tested according to 8.3 (torque test), 8.4.2.1 (tension test, general), 8.5 (drop test), 8.7 (impact test) and 8.8 (compression test) and for glued wooden toys 8.9 (soaking test). For *large and bulky toys*, the drop test is substituted by 8.6 (tip over test);

Cup-shaped toys, bowl-shaped toys and one half of egg-shaped toys shall comply with one or more of the requirements in items 5.12 a), b), c) or d):

- a) the object shall have two or more openings that are 13 mm or more from the rim as measured along the outside contour:
  - if the openings are placed in the base of the object, two or more of the openings shall be 13 mm or more apart (see Figure 16 a));
  - if the openings are not placed in the base of the object, two or more of the openings shall be placed at least 30° but not more than 150° apart (see Figure 16 b));
- b) the plane of the open end of the cup shape shall be interrupted at the centre by some type of divider that extends 6 mm or less from the plane of the opening. An example of an interruption includes a rib through the centre of the opening (see Figure 16 c));
- c) the object shall have three openings located between 6 mm and 13 mm from the rim and 100° or more apart as measured along the outside contour;
- d) the object shall have a repeating scalloped-edge pattern around the entire rim. The distance between centrelines of adjacent peaks shall be 25 mm or less and the depth shall be 6 mm or more (see Figure 16 d)).

For the purpose of these requirements, an opening is defined as a hole of any shape with a dimension of 2 mm or more.

The requirements above apply before and after testing according to 8.3 (torque test), 8.4.2.1 (tension test, general), 8.5 (drop test), 8.7 (impact test) and 8.8 (compression test) and for glued wooden toys 8.9 (soaking test). For *large and bulky toys* the drop test is substituted by 8.6 (tip over test).

NOTE See also the requirement in 6 e) regarding *packaging* which is hemispheric-shaped.

Dimensions in millimetres

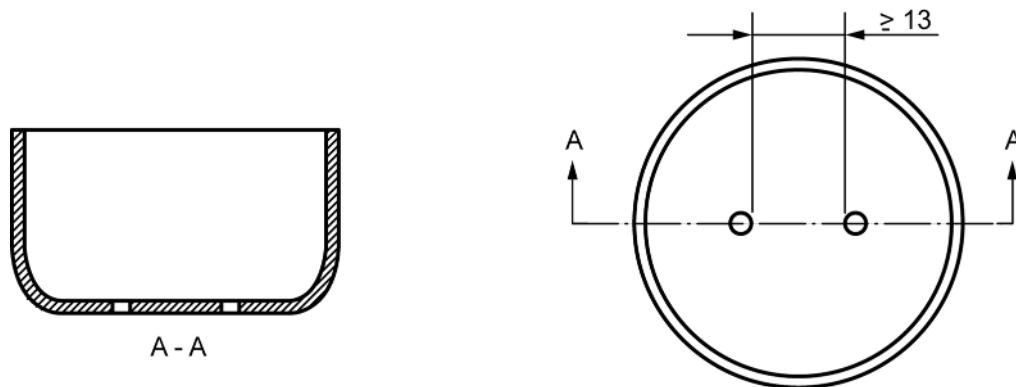

**a) Openings in the base of bowl**

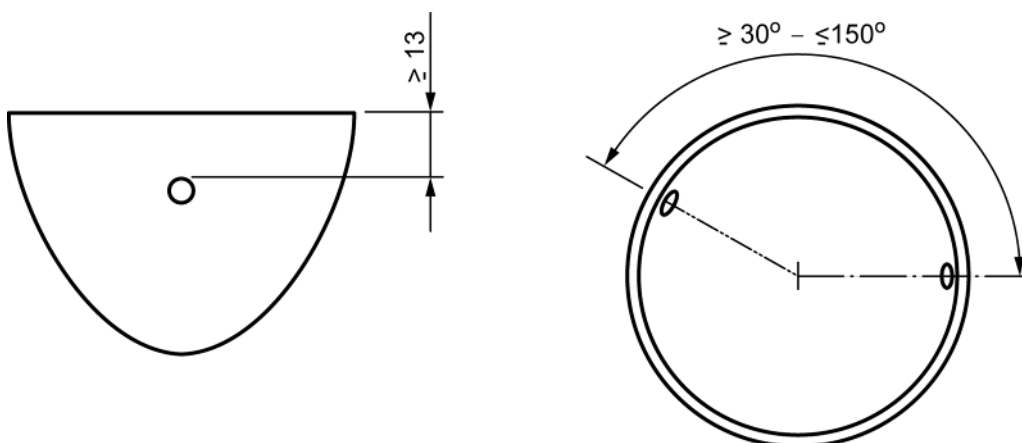

**b) Opening placement**

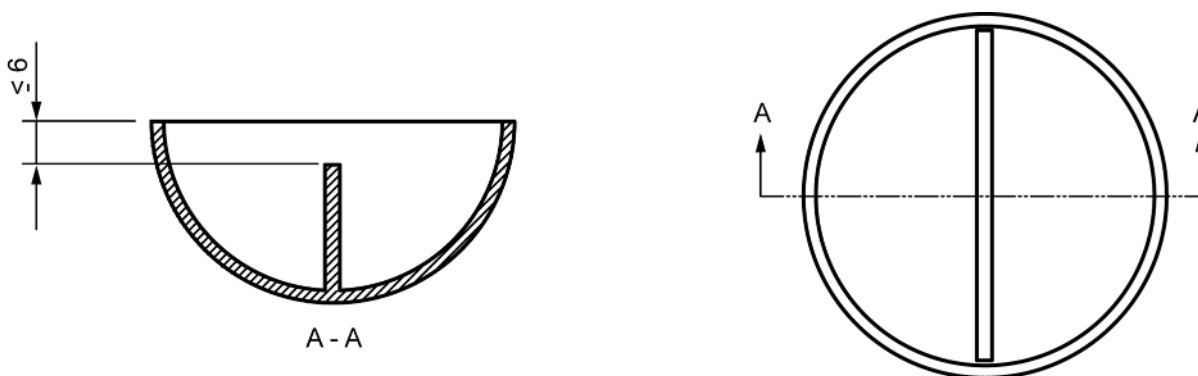

**c) Rib through cup centre**



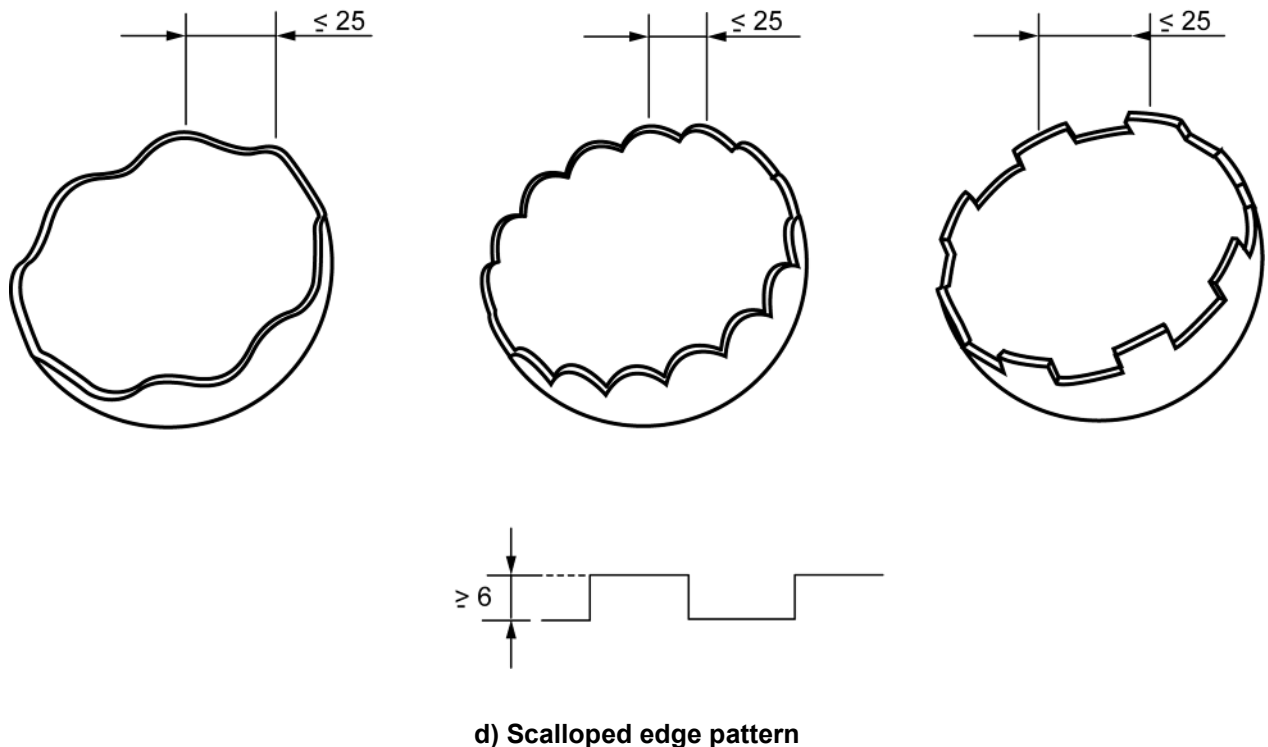

**Figure 16 — Examples of hemispheric-shaped toys**

### 5.13 Suction cups (see A.54)

- a) Loose *suction cups*, removable *suction cups* and *suction cups* that become detached from a toy when tested according to 8.3 (torque test), 8.4.2.1 (tension test, general), 8.5 (drop test), 8.7 (impact test) and 8.8 (compression test) shall not pass entirely through template E when tested according to 8.32.1 (small balls and suction cups) and shall continue to conform to relevant requirements in this European Standard. For *large and bulky toys*, the drop test is substituted by 8.6 (tip over test).
- b) A toy with an attached *suction cup* shall not pass entirely through template E when tested according to 8.32.1 (small balls and suction cups).

NOTE A *suction cup* that, together with a piece of *cord*, has become detached from a toy fails the requirement in 5.13 a) if it, and its attachment, pass through template E.

### 5.14 Straps intended to be worn fully or partially around the neck (see A.53)

Toys with *straps* intended to be worn fully or partially around the neck and which create a *fixed loop* shall have a breakaway feature which breaks when tested according to 8.38 (breakaway feature separation test).

## 6 Packaging (see A.56)

The requirement in Clause 6 a) does not apply to:

- shrunk-on film *packaging*, which is normally destroyed when the *packaging* is opened by the user;
- perforated *plastic sheeting* and bags made of perforated sheets which conform to the requirements in 4.3 b);
- *plastic sheeting* with *backing* or of an area equal to, or less than, 100 mm × 100 mm;

- **A3** bags made of flexible plastics of an area equal to, or less than, 100 mm x 100 mm, measured without cutting the bag open. **A3**

The *packaging* of toys shall conform to the following requirements:

- A3** *Plastic sheeting* and bags made of flexible plastics used for external or internal *packaging*, shall have an average sheet thickness of 0,038 mm or more when tested according to 8.25.1 (plastic sheeting, thickness). **A3**
- Bags made of flexible plastics with an opening perimeter greater than 380 mm shall not have a draw-string or *cord* as a means of closing.
- The requirements in 5.10 (small balls) apply to *packaging* and *packaging* components that are small *balls* regardless of the intended age group of the toy.
- Regardless of the intended age group of the toy, any separable part of its *packaging*, which is a small *ball* or that has a cylindrical shape with a rounded end shall not pass entirely through template E when tested according to 8.32.1 (small balls and suction cups). This requirement does not apply to parts with a major dimension of 64 mm or more, or parts that are attached to another part of the *packaging* with an attachment that does not break when tested according to 8.3 (torque test) and 8.4.2.1 (tension test, general).
- The requirements in 5.12 (hemispheric shaped toys) apply to hemispheric-shaped containers that are part of the *packaging* for toys intended for children under three.

## **7 Warnings, markings and instructions for use (see A.33)**

**NOTE** The text of this note is for information only and the indents do not constitute requirements of this European Standard. The information is not exhaustive and Directive 2009/48/EC and the associated guidance documents should be consulted for further details.

- Toys made available on the market must bear the CE marking. The CE marking is subject to the general principles set out in Article 30 of Regulation (EC) No 765/2008. The CE marking must be affixed visibly, legibly and indelibly to the toy, to an affixed label or to the *packaging*. In the case of small toys and toys consisting of small parts, the CE marking may alternatively be affixed to a label or an accompanying leaflet. Where, in the case of toys sold in counter displays, that is not technically possible, and on condition that the counter display was originally used as *packaging* for the toy, the CE marking may be affixed to the counter display. Where the CE marking is not visible from outside a *packaging*, it shall as a minimum be affixed to the *packaging*. Where specific legislation does not impose specific dimensions, the CE marking must be at least 5 mm high.
- The manufacturer's<sup>2</sup> name, registered trade name or registered trade mark and the address at which the manufacturer can be contacted must be indicated on the toy or, where that is not possible, on its *packaging* or in a document accompanying the toy. This requirement applies also to the name and address etc. of any importer<sup>3</sup>.
- Manufacturers must ensure that their toys bear a type, batch, serial or model number or other element allowing their identification, or where the size or nature of the toy does not allow it, that the required information is provided on the *packaging* or in a document accompanying the toy.
- Manufacturers and importers must ensure that the toy is accompanied by instructions and safety information in a language or languages easily understood by consumers, as determined by the Member State concerned.

---

<sup>2</sup> A manufacturer is any natural or legal person who manufactures a toy or has a toy designed or manufactured, and markets that toy under his name or trademark.

<sup>3</sup> An importer is any natural or legal person established within the Community who places a toy from a third country on the Community market.

- A Member State may, within its territory, stipulate that warnings and safety instructions shall be written in a language or languages easily understood by consumers, as determined by that Member State.
- Information relating to the age grading of toys and, in particular, which toys are intended for children under 36 months and which toys are not, can be found in CR 14379, the CPSC Age determination guidelines, CEN Guide 11 and the European Commission's Guidance Documents.

## 7.1 General

Warnings on toys shall not be misleading or incorrect. Toys intended for children under 36 months shall comply with the requirements in Clause 5. A warning on a toy or its *packaging* does not release the manufacturer or his authorized representative from the obligation to meet these requirements.

A toy shall not bear a warning that conflicts with the intended use of the toy, as determined by virtue of its function, dimension and characteristics.

The warnings shall be preceded by the words "Warning" or "Warnings", as appropriate (i.e. instead of repeating the word "Warning" before each warning when several of the warnings in Clause 7 are present, the word "Warnings" may be used once). The word "Warning" or "Warnings" may be followed by punctuation, e.g. an exclamation mark.

The manufacturer shall mark the warnings in a clearly visible, easily legible and understandable and accurate manner on the toy, on an affixed label or on the packaging **A1** and, if appropriate, include the warnings in the instructions for use.

Manufacturers shall for that purpose consider the good practice given in A.33. **A1**

In the following clauses, the location of the warnings is therefore indicated (on the toy itself, on the *packaging*, in the instructions for use, on an accompanying leaflet). Warnings which determine the decision to purchase the toy shall appear on the consumer *packaging* or be otherwise clearly visible to the consumer before the purchase.

Small toys that are sold without *packaging* (for example from a display box or from a vending machine) shall have the appropriate warnings affixed to them. In all cases the warning shall be clearly legible at the point of sale. It is not sufficient to place the warning(s) only on a display box.

NOTE The requirement that warnings must be clearly visible to the consumer at the time of purchase applies also in cases where the purchase is made on-line (e.g. internet) or by catalogue or by other means where the buyer does not have access to the toy at the time of purchase.

In the following sub-clauses a requirement, that a toy shall carry a warning shall mean that the warning shall appear on the toy itself.

## 7.2 Toys not intended for children under 36 months (see 4.22 and A.34)

The provisions in 7.2 do not apply to toys which, on account of their function, dimensions, characteristics, properties or other cogent grounds, are clearly unsuitable for children under 36 months. Toys which are not intended for but might be dangerous for children under 36 months shall be accompanied by a warning, such as:

"Warning. Not suitable for children under 36 months" or "Warning. Not suitable for children under three years"

together with a brief indication of the specific hazard calling for this restriction. The hazard is the potential source of harm. Harm means physical injury or any other damage to health, including long term health effect.

When more than one hazard is present, at least one of the principal hazards shall be indicated.

If the hazard (the potential source of harm) cannot be considered to be obvious to consumers, the hazard indication shall be supplemented by a clear description of the harm in order to explain the warning as a whole (e.g. “Long cord. Strangulation hazard” or “Small ball. Choking hazard”).

The harm may be referred to using e.g. the terms “Choking hazard” and “Strangulation hazard” since this is well established. However, it is never sufficient to indicate the harm alone (*choking*, strangulation etc.). In cases where it is well known which harm a product characteristic can cause (for example that “small parts” can cause *choking*) it is sufficient to indicate the hazard alone. It is, however, always permitted to mention both the hazard and the harm (e.g. “Small parts. Choking hazard”).

Examples of acceptable warnings, together with brief indications of the specific hazard and, in the second example, a clear description of the harm, are:

“Warning. Not suitable for children under 36 months. Small parts”

“Warning. Not suitable for children under 36 months. Long cord. Strangulation hazard”

The manufacturer shall provide appropriate information about the hazard(s) through the examples mentioned above or through other sentences that achieve the same result.

The age warning shall be clearly legible at the point of sale of the product and shall appear either on the toy itself or on its *packaging*.

The indication of the specific hazard may appear in a leaflet or in the instructions for use, instead of on the toy or on the *packaging*.

The phrase: “Not suitable for children under 36 months” or “Not suitable for children under three years” may be substituted by the symbol as specified in Figure 17.



**Figure 17 — Age-warning symbol**

The age warning symbol shall be accompanied by the word “Warning”.

The details of the design shall be as follows:

- the circle and the stroke shall be red;
- the background shall be white;
- the age range and the outline of the face shall be black;
- the symbol shall have a diameter of at least 10 mm and the proportions between its different elements shall be such as those prescribed in Figure 17.

The symbol shall be used to indicate only “0 to 3” years and not for any other age-grade warning to avoid misinterpretation of the symbol.

### 7.3 Latex balloons (see 4.12 and A.16)

The *packaging* of latex balloons shall carry the following warning:

"Warning. Children under eight years can choke or suffocate on uninflated or broken balloons. Adult supervision required. Keep uninflated balloons from children. Discard broken balloons at once."

The *packaging* of natural rubber latex balloons shall indicate "Made of natural rubber latex".

If there is no *packaging*, the information shall be on the balloons and/or on a leaflet accompanying the balloons.

### 7.4 Aquatic toys (see 4.18 and A.23)

*Aquatic toys* and their *packaging* shall carry the following warning:

"Warning. Only to be used in water in which the child is within its depth and under adult supervision."

The warning on the toy shall be visible, indelible and in a colour which contrasts with the body of the toy. The height of letters shall be 3 mm or more and the marking on inflatable *aquatic toys* shall be 100 mm or less from one of the air inflation inlets.

No advertising copy or graphics shall state or imply that the child will be safe with such a toy if left unsupervised.

### 7.5 Functional toys (see A.35)

*Functional toys* and their *packaging* shall carry the following warning:

"Warning. To be used under the direct supervision of an adult."

In addition, these toys shall be accompanied by directions giving working instructions and precautions to be taken by the user, with the warning that failure to take these precautions would expose the user to the hazards – to be specified – normally associated with the appliance or product of which the toy is a scale model or an imitation. It shall also be indicated that the toy shall be kept out of the reach of children under a certain age which shall be specified by the manufacturer.

### 7.6 Hazardous sharp functional edges and points (see 4.7 and 4.8)

For toys that incorporate hazardous sharp *functional edges* (see 8.11, sharpness of edges) or hazardous sharp *functional points* (see 8.12, sharpness of points), attention shall be drawn to the potential hazards of such points and *edges* on the *packaging* and in the instructions for use accompanying the toy, if appropriate.

### 7.7 Projectiles (see 4.17.3 c) and 4.17.4 c))

#### 7.7.1 Toys with projectiles which are able to discharge an object other than that provided with the toy

Toys with *projectiles* which are able to discharge an object other than that provided with the toy shall be accompanied by instructions for use which draw attention to the hazards of using missiles other than those supplied or recommended by the manufacturer.

### **7.7.2 Toys capable of discharging a projectile with a kinetic energy greater than 0,08 J**

Toys capable of discharging a *projectile* with a kinetic energy greater than 0,08 J shall carry the following warning on the toy and/or its *packaging* and in the instructions for use:

"Warning. Do not aim at eyes or face."

### **7.8 Imitation protective masks and helmets (see 4.14.2 and A.19)**

Toys that are imitations of protective masks and helmets (for example motorcycle helmets, industrial safety helmets and fireman's helmets) and their *packaging* shall carry the following warning:

"Warning. This toy does not provide protection."

### **7.9 Toy kites (see 4.13)**

Toy kites and other flying toys with *cords* exceeding 2 m linking the toy to the child shall carry the following warning:

"Warning. Do not use near overhead power lines or during thunderstorms."

### **7.10 Roller skates, inline skates, skateboards and certain other ride-on toys (see 4.15.1.2 and A.20)**

#### **7.10.1 Roller skates, inline skates and skateboards**

Roller skates, inline skates and skateboards for children offered for sale as toys, and their *packaging*, shall carry the following warning:

"Warning. Protective equipment should be worn. Not to be used in traffic. 20 kg max."

#### **7.10.2 Ride-on toys without a braking device**

Where required according to 4.15.1.2, ride-on toys without a braking device shall carry the following warning:

"Warning. This toy has no brake."

#### **7.10.3 Electrically-driven ride-on toys**

Where required according to 4.15.1.2, electrically-driven ride-on toys and/or their *packaging*, and the accompanying instructions for use, shall carry the following warning:

"Warning. Protective equipment should be worn. Not to be used in traffic."

In addition, electrically-driven ride-on toys and/or their *packaging*, and the accompanying instructions for use, shall carry the following warnings which shall be clearly visible to the consumer at the point of sale:

— a warning, preceded by the word "Warning", which draws attention to the potential hazards of using the toy in areas other than private grounds;

— a warning regarding the age group for which the toy is intended, with regard to the limitations specified in 4.15.1.8, either:

"Warning. This toy is unsuitable for children under 3 years due to its maximum speed.", or

"Warning. This toy is unsuitable for children under 6 years due to its maximum speed."

#### 7.10.4 Instructions for use

Apart from the information and warning required by 4.15.1.2, the instructions for use of toys intended to bear the mass of a child, other than *toy bicycles* and *toy scooters*, shall contain:

- examples of safe riding areas;
- a recommendation for adult supervision of young children;
- instructions to be given to the child in the proper use of the toy, particularly in the use of any braking system;
- a reminder that the toy should be used with caution since skill is required to avoid falls or collisions causing injury to the user or third parties.

If the toy carries a warning regarding protective equipment, some indication shall also be given in the instructions for use with regard to recommended protective equipment (helmet, gloves, knee-pads, elbow-pads etc.).

#### 7.11 Toys intended to be attached to or strung across a cradle, cot, or perambulator (see 5.4 f))

Toys covered by the requirement in 5.4 f) and their *packaging* shall carry the following warning:

"Warning. To prevent possible injury by entanglement, remove this toy when the child starts trying to get up on its hands and knees in a crawling position."

#### 7.12 Liquid-filled teethingers (see 5.5)

Liquid-filled *teethers* or their *packaging* shall carry the following instruction:

"Cool only in a refrigerator. Do not place in the freezer compartment."

#### 7.13 Percussion caps specifically designed for use in toys (see 4.19)

The *packaging* of percussion caps shall carry the following warning:

"Warning. Do not fire indoors or near eyes and ears. Do not carry caps loose in a pocket."

**A<sub>2</sub>**

#### 7.14 Acoustics (see 4.19 and 4.20)

*Percussion toys* and *cap-firing toys* which produce high impulse sound levels, or their *packaging*, shall carry the following warning:

"Warning. Do not use close to the ear! Misuse may cause damage to hearing."

For toys using percussion caps add adjacent to the text above:

"Do not fire indoors! Use only percussion caps recommended by the manufacturer." **A<sub>2</sub>**

### **7.15 Toy bicycles (see 4.15.2.2)**

*Toy bicycles* and their *packaging* shall carry the following warning:

"Warning. Protective equipment should be worn. Not to be used in traffic."

The instructions for use shall contain a reminder that the toy shall be used with caution, since skill is required to avoid falls or collisions causing injury to the user or third parties. The instructions for use shall also give an indication as to recommended protective equipment, and shall provide the following information that should be explained to the child:

- instructions in the proper use of the braking system;
- a reminder that the bicycle is not suitable for use on public highways.

### **7.16 Toys intended to bear the mass of a child (see 4.15.1.2, 4.15.2.2, 4.15.3 and 4.15.4)**

Toys that due to their construction, strength, design or other factors are not suitable for children of 36 months and over shall carry the following warning on the toy and its *packaging*:

"Warning. Not to be used by children over 36 months."

together with a brief indication of the specific reason for this restriction (e.g. insufficient strength).

The age warning shall be clearly legible at the point of sale of the product.

### **7.17 Toys comprising monofilament fibres (see 5.9)**

Toys comprising monofilament fibres of straightened length greater than 50 mm attached to a fabric base, or their *packaging*, shall carry the following warning:

"Warning. Not suitable for children under 10 months due to long hair."

### **7.18 Toy scooters (see 4.15.5.2)**

*Toy scooters* intended for children with a body mass of 20 kg or less and their *packaging* shall carry the following warning:

"Warning. Protective equipment should be worn. Not to be used in traffic. 20 kg max."

*Toy scooters* intended for children with a body mass of 50 kg or less and their *packaging* shall carry the following warning:

"Warning. Protective equipment should be worn. Not to be used in traffic. 50 kg max."

The instructions for use shall contain a reminder that the toy shall be used with caution, since skill is required to avoid falls or collisions causing injury to the user or third parties. The instructions for use shall also, as appropriate, include information such as:

- the warning indicated above;
- how to safely fold or unfold foldable scooters;
- the necessity to ensure that all locking devices are engaged;
- the dangers of using *toy scooters* on public highways;



- a recommendation to use protective equipment such as a helmet, gloves, knee-pads and elbow-pads.

### 7.19 Rocking horses and similar toys (see 4.15.3 and A.21)

Rocking horses and similar toys, where the intended sitting surface is 600 mm or more above the ground, shall carry the following warning:

“Warning. Risk of falling. Do not leave children under 36 months sitting or playing unattended.”.

The warning shall be clearly legible at the point of sale of the product.

### 7.20 Magnetic/electrical experimental sets (see 4.23.3 and A.51)

The *packaging* and the instructions for use of *magnetic/electrical experimental sets* intended for children over 8 years shall carry the following warning:

“Warning. Not suitable for children under 8 years. This product contains (a) small magnet(s). Swallowed magnets can stick together across intestines causing serious injuries. Seek immediate medical attention if magnet(s) are swallowed.”.

This warning is not required for *magnetic/electrical experimental sets* in which all magnets have a magnetic flux index less than  $50 \text{ kG}^2\text{mm}^2$  ( $0,5 \text{ T}^2\text{mm}^2$ ) when tested according to 8.35 (magnetic flux index), or do not fit entirely in the cylinder when tested according to 8.2 (small parts cylinder).

### 7.21 Toys with electrical cables exceeding 300 mm in length (see 5.4 i)

Toys intended for children under 36 months, with *electrical cables* longer than 300 mm and their *packaging* shall carry the following warning:

“Warning. Long cable. Strangulation hazard.”.

### 7.22 Toys with cords or chains intended for children of 18 months and over but under 36 months (see 5.4 b), 5.4 c) and 5.4 g))

Toys intended for children of 18 months and over but under 36 months shall, when required by 5.4 carry the following warning on the toy or its *packaging*:

“Warning. Not suitable for children under 18 months. Long cord/Long chain. Strangulation hazard.”.

The age warning shall be clearly legible at the point of sale of the product.

## 8 Test methods

### 8.1 General requirements for testing

This European Standard specifies different forces and/or loads to be used when testing toys intended for children of different age groups. If no age group is specified, or a toy spans over more than one age group, or there is reasonable doubt as to which age group the toy is intended for, the toy shall be subjected to the more severe test.

The tests shall be performed in the order specified in the requirements. If a toy during a test has been materially affected by a clamp or similar test equipment, the following test(s) shall be performed on a new toy.

## 8.2 Small parts cylinder (see 4.6, 4.11, 4.18, 4.23.2, 4.23.3, 4.25, 5.1, 5.2 and A.36)

Place the toy or component without compressing it and in any orientation in a cylinder having dimensions as indicated in Figure 18.

Determine whether the toy or component fits entirely within the cylinder.

Dimensions in millimetres

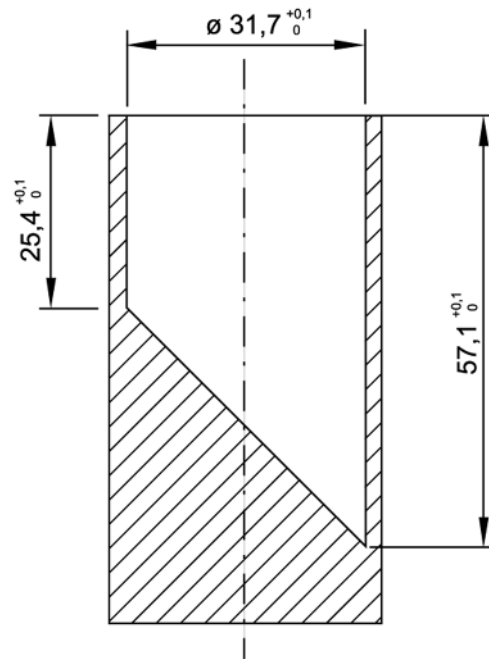

Figure 18 — Small parts cylinder

## 8.3 Torque test (see 4.6, 4.11, 4.14.2, 4.17, 4.18, 4.22, 4.23.2, 4.25, 5.1, 5.10, 5.12, 5.13 and Clause 6)

If a component can be gripped between thumb and forefinger, gradually apply a torque to the component over a period of approximately 5 s in a clockwise direction until either

- a rotation of 180° from the original position has been attained, or
- a torque of 0,34 Nm is reached.

Maintain the maximum rotation or required torque for 10 s. Permit the test component to return to a relaxed condition. Repeat this procedure in a counter-clockwise direction.

To prevent rotation, projections, parts, or assemblies that are rigidly mounted on an *accessible* rod or shaft designed to rotate along with the projections, parts, or assemblies, shall be tested with the rod or shaft clamped.

If a component which is attached by a screw thread becomes loosened during application of the required torque, continue to apply the torque until the required torque is exceeded or the part disassembles, or until it becomes apparent that the part will not disassemble.

## 8.4 Tension test (see A.37)

### 8.4.1 Apparatus

8.4.1.1 **Tensile testing machine or dead-weight arrangement** with means of applying forces up to at least 90 N with an accuracy of 2 N

#### 8.4.1.2 Clamps and straps

8.4.1.3 **Feeler gauge** with a thickness of  $(0,4 \pm 0,02)$  mm and an insertion *edge* radius of approximately 3 mm (see Figure 19)

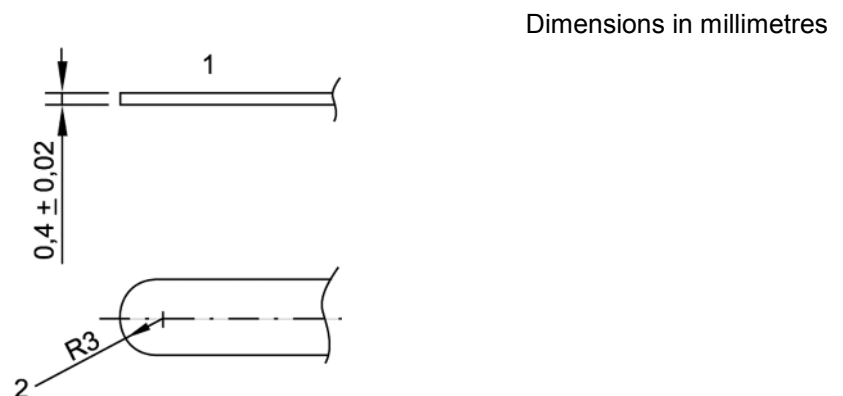

#### Key

- 1 edges broken
- 2 insertion edge radius

Figure 19 — Feeler gauge

### 8.4.2 Procedure

#### 8.4.2.1 General (see 4.6, 4.11, 4.14.2, 4.17, 4.18, 4.22, 4.23, 4.25, 5.1, 5.3, 5.10, 5.12, 5.13 and Clause 6)

If a requirement indicates that 8.3 (torque test) and 8.4 (tension test) shall be performed, the tension test shall follow after the torque test and be performed on the same component of the toy.

If the component to be tested cannot be gripped between thumb and forefinger, establish whether it is grippable by inserting the feeler gauge between the component and the underlying layer or body of the toy at an angle between  $0^\circ$  and  $10^\circ$  from the toy surface using a force of  $(10 \pm 1)$  N. If the gauge can be inserted more than 2 mm, the component shall be considered as grippable.

If the component is grippable, affix a suitable clamp behind the component taking care not to damage the attachment mechanism or the body of the toy.

Fasten the toy in the test apparatus and apply a tensile force to the component by means of a clamp or by other means.

In the case of *projectiles* with a *suction cup* as impact area, one suitable clamp or other device shall be attached around the *suction cup* and one at the other end of the *projectile* (see Figure 20). The distance from the end of the *suction cup* to the front *edge* of the clamp shall be  $(57 \pm 1)$  mm or, if the *projectile* is too short to allow this, the clamps shall be placed such that the distance is maximized. This distance shall be measured with the *suction cup* in an uncompressed state. The distance will allow the clamps to be attached to *projectiles*

with the shortest permissible length (57 mm) and will also ensure that any weak points of the shaft are detected (i.e. weak points that, when subjected to a tension force, could result in a shaft-part with a *suction cup* that has a total length of less than 57 mm). In the case of *projectiles* where the *projectile* is not moulded in one piece, it shall be ensured that the *suction cup* is not clamped to the shaft during the test.

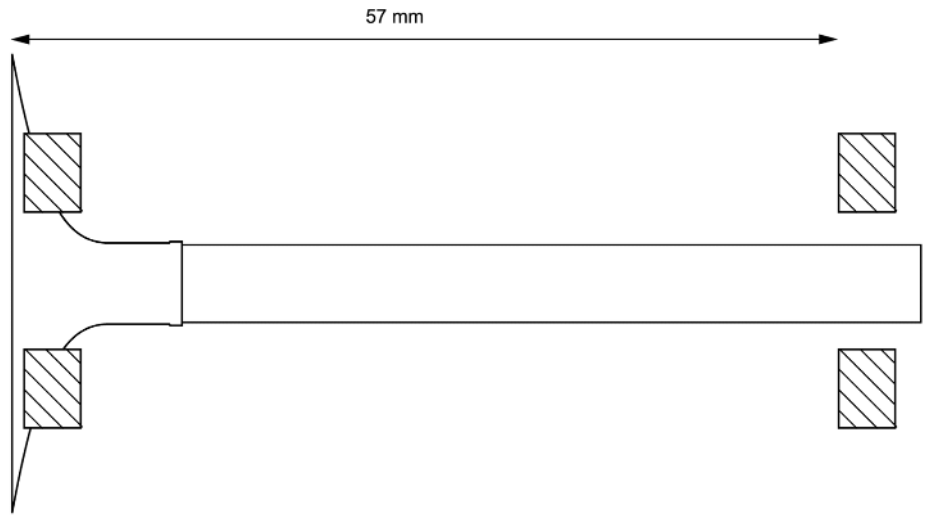

**Key**



**Figure 20 — Example of attachment of clamps when testing suction cups on projectiles**

Apply a force of:

- $(50 \pm 2)$  N when the largest *accessible* dimension of the component to be gripped and tested is 6 mm or less, or
- $(90 \pm 2)$  N when the largest *accessible* dimension of the component to be gripped and tested is greater than 6 mm,  $\text{A}_3$  or  $\text{A}_3$
- $\text{A}_3$   $(25 \pm 2)$  N when the component to be gripped is made entirely of *paperboard*.  $\text{A}_3$

Apply the force gradually over a period of approximately 5 s. Maintain the force for 10 s.

Determine whether the component or *suction cup* has become detached or if the shaft of the *projectile* has broken.

Determine whether the *projectile* continues to conform to the relevant requirements of this European Standard.

If the clamp or other device causes any damage to the *projectile*, either clamp the *suction cup* only and apply the torque and the tension force to it (for example by attaching a weight to the clamp while holding the shaft between the thumb and the forefinger), or glue the *suction cup* to an even surface by means of a suitable glue and subsequently carry out the torque test and tension test as described above. Care shall then be taken that the solvents, which can possibly be set free from the glue, do not influence the material properties of the *suction cup* or its *fastening* to the shaft such that the test results in incorrect failures.

**8.4.2.2 Seams and materials (see 4.23.2 and 5.2)**

- a) *Soft-filled toys* containing small parts

Use clamps with jaws to which discs with a diameter of 19 mm are affixed.

Remove any clothing supplied with the toy. Attach the clamps at the most onerous position of the casing (e.g. seam joint between the leg and body) not less than 30 mm apart and equidistant to the seam.

If there is insufficient material to fully attach the 19 mm disc jaws, the tension test below shall be performed on another appropriate part (e.g. a limb), instead of across the seam.

Gradually apply a force of  $(70 \pm 2)$  N between the two clamps over a period of approximately 5 s. Maintain the force for 10 s.

Apply the test to this area of casing or seam only once.

Determine whether it is possible to insert the front part of accessibility probe A (see Figure 21) under a force of 10 N or less.

b) Other *soft-filled* toys

Follow the procedure described in the first four paragraphs of 8.4.2.2 a). Determine whether the front part of a  $12_{-0}^{+0,1}$  mm diameter rod, with a fully radiused end, can be inserted through any one opening in the seam or cover material, using a maximum force of 10 N.

#### 8.4.2.3 Protective components (see 4.9 and 4.17.1)

Gradually apply a force of  $(60 \pm 2)$  N over a period of approximately 5 s. Maintain the force for 10 s.

Determine whether the component has become detached.

### 8.5 Drop test (see 4.5, 4.6, 4.10.2, 4.14.2, 4.22, 4.23.2, 4.25, 5.1, 5.10, 5.12 and 5.13)

Drop the toy, or the relevant toy component, five times through a height of  $(850 \pm 50)$  mm on to a 4 mm thick steel plate with a 2 mm thick coating of Shore A hardness  $(75 \pm 5)$  as measured according to EN ISO 868 or ISO 7619-2 and which is placed on a non-flexible horizontal surface.

Prior to release, orientate the toy in a position that allows the most onerous impact onto the coated surface of the steel plate.

Determine whether the casing of toys intended for children too young to sit up unaided has separated into parts or *cracked*. Determine whether small parts (8.2, small parts cylinder), hazardous sharp *edges* (8.11, sharpness of edges), hazardous sharp points (8.12, sharpness of points) or hazardous *driving mechanisms* (4.10.2, driving mechanisms) have become *accessible*.

### 8.6 Tip over test (see 4.10.2, 4.22, 4.23.2, 5.1, 5.10, 5.12 and 5.13)

Place the toy on a horizontal surface as prescribed in 8.5 (drop test) and attempt to tip it over by pushing the toy slowly past its centre of balance three times, one of which shall be in its most onerous position, by gradually applying a force, which is not to exceed 120 N, in a horizontal direction and 1 500 mm above the horizontal surface or at the top *edge* of the toy for toys less than 1 500 mm in height. A non-resilient step with a height of  $(25 \pm 2)$  mm shall be positioned such that it prevents sliding or rolling of the toy during the test.

The original point of application relative to the toy shall be maintained, and the force shall remain horizontal, throughout the test. The vertical position of the point of application relative to the horizontal surface is permitted to increase during the test. The test shall also be stopped if the toy slides or rolls over the non-resilient step without tipping over.

If a force greater than 120 N is required to bring the toy beyond its centre of balance, or if the vertical position of the point of application, relative to the horizontal surface, exceeds 1 800 mm, the tip-over test shall be stopped.

NOTE 1 800 mm corresponds to the length (95<sup>th</sup> percentile) of a 14-year-old child.

Toys supplied with anchors and intended to be permanently fixed (e.g. in concrete) when in use according to the manufacturer's instructions, shall not be subjected to the tip-over test.

Determine whether small parts (8.2, small parts cylinder), hazardous sharp *edges* (8.11, sharpness of edges), hazardous sharp points (8.12, sharpness of points) or hazardous *driving mechanisms* (4.10.2, driving mechanisms) have become *accessible* and whether small *balls* (4.22 and 5.10, small balls) or hemispheric-shaped toys (5.12, hemispheric-shaped toys) have become detached.

### **8.7 Impact test (see 4.5, 4.6, 4.10.2, 4.14.2, 4.22, 4.23.2, 4.25, 5.1, 5.10, 5.12, 5.13 and A.38)**

Place the toy, or the relevant toy component, in its most onerous position on a plane horizontal steel surface and drop a metallic weight with a mass of  $(1 \pm 0,02)$  kg, distributed over an area with a diameter of  $(80 \pm 2)$  mm, through a distance of  $(100 \pm 2)$  mm on to the toy.

Perform the test once.

Determine whether the casing of toys intended for children too young to sit up unaided has separated into parts or *cracked*. Determine whether small parts (8.2, small parts cylinder), hazardous sharp *edges* (8.11, sharpness of edges), hazardous sharp points (8.12, sharpness of points) or hazardous *driving mechanisms* (4.10.2, driving mechanisms) have become *accessible*.

### **8.8 Compression test (see 4.6, 4.14.2, 4.22, 4.23.2, 4.25, 5.1, 5.10, 5.12, 5.13 and A.39)**

Any *accessible* area on the surface of a toy that is *inaccessible* to flat surface contact during the drop test (8.5) or tip over test (8.6) shall be subjected to a compression test.

Place the toy on a horizontal rigid surface with the part of the toy to be tested uppermost. Apply a compression force of  $(110 \pm 5)$  N through a rigid metal disc with a diameter of  $(30 \pm 1,5)$  mm to the area to be tested. The perimeter of the disc shall be rounded.

Apply the force gradually over a period of approximately 5 s. Maintain the force for 10 s.

Determine whether the casing of toys intended for children too young to sit up unaided has separated into parts or *cracked*. Determine whether small parts (8.2, small parts cylinder), hazardous sharp *edges* (8.11, sharpness of edges), hazardous sharp points (8.12, sharpness of points) or hazardous *driving mechanisms* (4.10.2, driving mechanisms) have become *accessible*.

### **8.9 Soaking test (see 4.11, 4.23.2, 5.1, 5.10 and 5.12)**

Submerge the toy or the component completely in a container of demineralised water at a temperature of  $(20 \pm 5)$  °C for 4 min. Remove the toy, shake off excess water and keep the toy at room temperature for 10 min.

Perform the test cycle four times.

Immediately after the last cycle, determine whether any components released fit entirely in the cylinder when tested according to 8.2 (small parts cylinder).

## 8.10 Accessibility of a part or component (see 4.5, 4.7, 4.8, 4.10.2, 4.10.4, 4.15.1.3, 4.21, 5.2 and 5.7)

### 8.10.1 Principle

An articulated probe is manoeuvred to the part or component being tested. If the probe contacts the part or component, the part or component is considered to be *accessible*.

### 8.10.2 Apparatus

Articulated *accessibility* probes illustrated in Figure 21, manufactured from rigid material, and with dimensions as specified in  $\square_{A2}$  Table 3  $\square_{A2}$ . The tolerance on the dimensions shall be  $\pm 0,1$  mm except for *f* and *g* which shall have a tolerance of  $\pm 1$  mm.

### 8.10.3 Procedure

Remove all components that are intended to be removed without the use of a *tool*.

NOTE 1 Where a *tool* is intended to be used in conjunction with the toy during play, all the components on the toy that are capable of being removed by that *tool* should be removed.

Manoeuvre, as described in a), b) and c), the appropriate articulated *accessibility* probe in any convenient attitude towards the part or component to be tested and, if necessary, pivot the probe at any of its joints in an attempt to contact that part or component.

NOTE 2 Each probe joint may be rotated up to  $90^\circ$  to simulate knuckle movement.

NOTE 3 Where the part is a sharp point that lies adjacent to a plane surface so that the gap between the point and the surface is 0,5 mm or less, the point is considered to be *inaccessible* and the procedure specified in b) need not be performed.

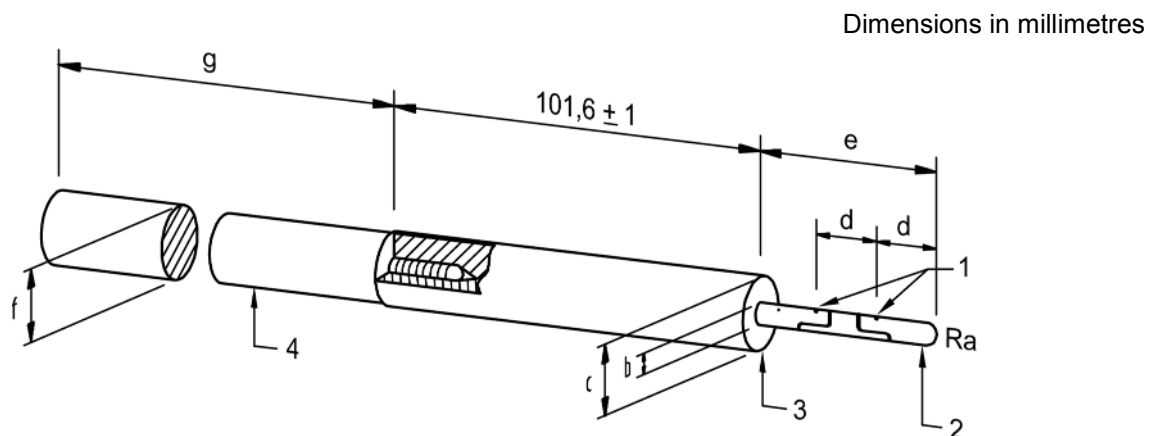

#### Key

- 1 pivot points
- 2 spherical radius ( $R_a$ )
- 3 collar
- 4 extension

Figure 21 — Accessibility probe



Table 3 — Dimensions of accessibility probes

Age group	Probe	Dimensions (mm)						
		$R_a$	$b$	$c$	$d$	$e$	$f$	$g$
Under 36 months	A	2,8	5,6	25,9	14,7	44,0	25,4	464,3
36 months and over	B	4,3	8,6	38,4	19,3	57,9	38,1	451,6
Toys intended for children of both age groups	A and B (both probes shall be used)	According to specifications above.						

- a) For any hole, recess, or other opening having a minor dimension (see Note 4) smaller than the collar diameter of the appropriate probe, insert the probe so that the total insertion depth for *accessibility* is up to the collar;

NOTE 4 The minor dimension of an opening is the diameter of the largest sphere that will pass through the opening.

- b) for any hole, recess, or other opening having:

— a minor dimension larger than the diameter of the collar of probe A but less than 187 mm when probe A is used, or

— a minor dimension larger than the diameter of the collar of probe B but less than 230 mm when probe B is used,

— determine the total insertion depth for *accessibility* by inserting the appropriate probe, with the extension shown in Figure 21 in any direction for up to 2,25 times the minor dimension of the hole, recess, or opening, measured from any point in the plane of the opening;

- c) for any hole, recess, or other opening having:

— a minor dimension of 187 mm or larger when probe A is used, or

— a minor dimension of 230 mm or larger when probe B is used,

the total insertion depth for *accessibility* is unrestricted unless other holes, recesses, or openings within the original hole, recess, or opening are encountered that have dimensions conforming to a) or b) of this sub-clause; in such instances, follow the procedure in a) or b) as appropriate. If both probes shall be used, a minor dimension of 187 mm or larger shall determine the unrestricted access.

Determine whether a tested part or component can be contacted by any portion forward of the collar of the *accessibility* probe.

## 8.11 Sharpness of edges (see 4.5, 4.7, 4.9, 4.10.2, 4.14.2, 4.15.1.3 and 5.1)

### 8.11.1 Principle

A self-adhesive *tape* is attached to a mandrel which is then rotated for a single 360° revolution along the *accessible edge* being tested. The *tape* is then examined for the length of cut.



## 8.11.2 Apparatus

### 8.11.2.1 General

The apparatus shall be as illustrated in Figure 22.

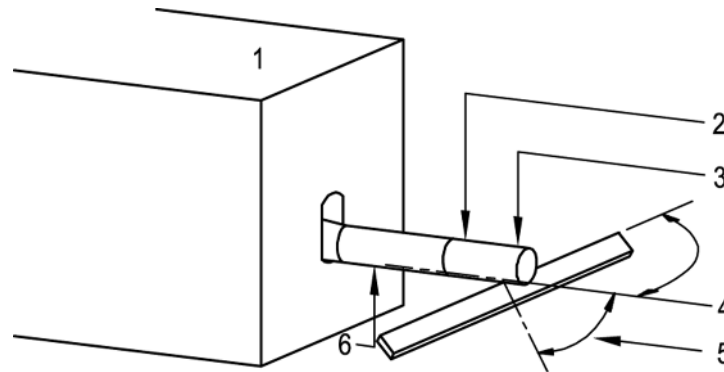

#### Key

- 1 any suitable device, portable or non-portable, to apply a known force and rotation to the mandrel
- 2  $(6 \pm 0,5)$  N applied to the mandrel axis
- 3 single wrap of self-adhesive *tape*
- 4  $(90 \pm 5)^\circ$  (test *edge* relationship to mandrel)
- 5 variable angle to seek worst case situation
- 6 during the test the mandrel rotates one full revolution

Figure 22 — Edge test apparatus

### 8.11.2.2 Mandrel, made of steel

The test surface of the mandrel shall be free from scratches, nicks or *burr* and shall have a surface roughness  $R_a$  according to EN ISO 4287 which is not greater than  $0,40 \mu\text{m}$ . The surface shall have a Rockwell C scale hardness of not less than 40 when measured according to EN ISO 6508-1. The diameter of the mandrel shall be  $(9,53 \pm 0,12)$  mm.

### 8.11.2.3 Device for rotating the mandrel and applying a force to it

The device shall be capable of rotating the mandrel at a constant tangential velocity of  $(23 \pm 4)$  mm/s during the central 75 % of its  $360^\circ$  travel, starting and stopping of the mandrel being smooth. Portable or non-portable and of any suitable design, the device shall be capable of applying any force up to 6 N to the mandrel, perpendicular to the mandrel axis.

### 8.11.2.4 Self-adhesive tape

The self-adhesive *tape* shall be pressure-sensitive polytetrafluoroethylene (PTFE) high temperature electrical insulation *tape*.

The thickness of the polytetrafluoroethylene *backing* shall be between 0,066 mm and 0,090 mm. The adhesive shall be pressure-sensitive silicone polymer with a nominal thickness of 0,08 mm. The width of the *tape* shall be 6 mm or more. During the tests, the temperature of the *tape* shall be maintained at  $(20 \pm 5) ^\circ\text{C}$ .

### **8.11.3 Procedure**

Ascertain that the *edge* to be tested is *accessible* by the method described in 8.10 (accessibility of a part or component).

Support the toy in such a manner that the *accessible edge* to be tested does not bend or move when the force of the mandrel (8.11.2.3) is applied. Ensure that the support is 15 mm or more from the *edge* to be tested.

If part of the toy has to be removed or disassembled in order to test a particular *edge*, and as a result, the rigidity of the *edge* being tested is affected, support the *edge* so that its stiffness approximates to the *edge* stiffness in the assembled toy.

Wrap the mandrel with one layer of the *tape* (8.11.2.4) to provide a sufficient area for performing the test.

Place the d mandrel so that its axis is at  $(90 \pm 5)^\circ$  to the line of a straight *edge*, or at  $(90 \pm 5)^\circ$  to a tangent at the test point of a curved *edge*, and the *tape* is in contact with the sharpest part of the *edge* (i.e. the worst case situation) when the mandrel is rotated (see Figure 22).

Apply a force of  $(6 \pm 0,5)$  N to the mandrel at the centre of the *tape* and rotate the mandrel  $360^\circ$  about its axis against the *edge*, ensuring that no relative motion occurs between the mandrel and the *edge* during the rotation of the mandrel. If this procedure causes the *edge* to bend, apply the maximum force that will not cause the *edge* to bend.

Remove the *tape* from the mandrel without enlarging any cut in the *tape* or causing any score in the *tape* to become a cut. Measure the length of *tape* that is cut, including any intermittent cuts. Measure the length of *tape* which has contacted the *edge* during the test. In this way, calculate the percentage of the length of *tape* which has been cut during the test. If this is more than 50 % of the contact length, the *edge* tested is considered to be a sharp *edge*.

## **8.12 Sharpness of points (see 4.5, 4.8, 4.9, 4.10.2, 4.14.2, 4.15.1.3, 5.1 and A.40)**

### **8.12.1 Principle**

A point tester is applied to an *accessible* sharp point and it is determined whether or not the point being tested penetrates a specified distance into the sharp point tester.

### **8.12.2 Apparatus**

**Point tester** (for example as shown in Figure 23).

A rectangular opening measuring  $(1,02 \pm 0,02)$  mm by  $(1,15 \pm 0,02)$  mm in the end of the slotted cap establishes two reference dimensions. The sensing head is recessed  $(0,38 \pm 0,02)$  mm below the end cap. There is a distance of  $(0,12 \pm 0,02)$  mm between it and a return *spring* having a force of  $2,5_{-0,3}^0$  N.

Dimensions in millimetres

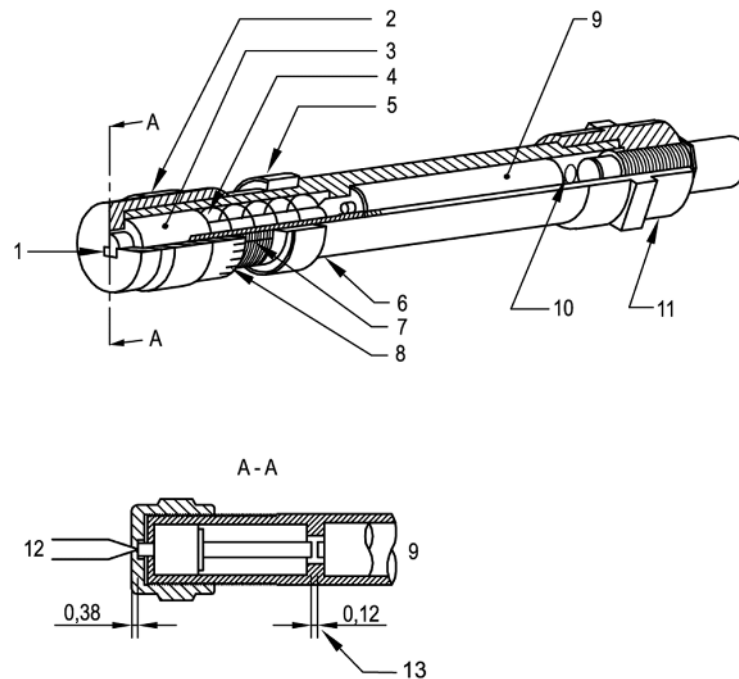

**Key**

- 1 gauging slot
- 2 gauging cap
- 3 sensing head
- 4 loading *spring*
- 5 lock ring
- 6 barrel
- 7 adjusting reference mark
- 8 micrometer divisions
- 9 R03 dry cell
- 10 electrical contact *spring*
- 11 indicator lamp assembly and adapter nut
- 12 test point
- 13 gap is closed upon insertion of sufficiently sharp point to pass through gauging slot and depress sensing head 0,12 mm. Electrical circuit is thereby completed and indicator test lamp lights – sharp point fails test

**Figure 23 — Point tester**

**8.12.3 Procedure**

Ascertain that the point to be tested is *accessible* by the method described in 8.10 (accessibility of a part or component).

Support the toy in such a manner that the *accessible* point to be tested does not move during the test. In most cases it will not be necessary to support the point directly; if necessary, ensure that the support is 6 mm or more from the point to be tested.

If part of the toy has to be removed or disassembled in order to test a particular point, and, as a result, the rigidity of the point being tested is affected, support the point so that its stiffness approximates to the point stiffness in the assembled toy.

Adjust the point tester (8.12.2) by loosening the locking ring and rotating it so that it moves a distance toward the indicator lamp assembly sufficient to expose the calibration reference mark on the barrel. Rotate the gauging cap clockwise until the indicator lamp lights. Rotate the cap counter-clockwise until the sensing head moves a distance of  $(0,12 \pm 0,02)$  mm from making contact with the dry cell, as shown in Figure 23.

**NOTE** Where the gauging cap includes micrometer markings, the distance may be readily achieved by rotating the cap counter-clockwise until the appropriate micrometer marking corresponds to the calibration reference mark. The gauging cap may now be locked in this position by rotating the locking ring until it fits firmly against the cap.

Insert the point into the cap slot in the direction which confers the greatest rigidity on the point, and apply a force of 4,5 N to depress the *spring* as far as possible without shaving the point on the *edges* of the slot or extruding the point through the slot.

Determine whether or not the indicator lamp lights up.

If the point penetrates a distance of 0,50 mm or more into the gauging slot, causing the indicator lamp to light, and the point maintains its original shape while under a force of 4,5 N, the point tested is considered to be a sharp point.

### **8.13 Flexibility of metallic wires (see 4.8 and A.41)**

#### **8.13.1 General**

If the metallic wire has a covering, apply the test to the metallic wire in the condition in which it appears in the toy (i.e. do not remove the metallic wire from the toy).

Grip the metallic wire firmly between two metal cylinders, radiused pliers, or equivalent metal pieces with a diameter of  $(10 \pm 1)$  mm. At a point 50 mm from the point of gripping or, if less than 50 mm protrudes, at the end of the metallic wire, apply a force of  $(70 \pm 2)$  N perpendicular to the metallic wire. If the metallic wire bends more than  $60^\circ$ , continue the test as follows.

Bend the metallic wire from the upright position to one side through  $60^\circ$ , and then bend in the opposite direction through  $120^\circ$ , and finally return to the upright position. This is one cycle.

#### **8.13.2 Metallic wires and other metallic components intended to be bent**

Perform the cycle described in 8.13.1 (general) 30 times at a rate of one cycle per 2 s with a 60 s rest period after each 10 cycles. To ensure that the metallic wire or other metallic component bends at the point emerging from the cylinders, it shall be kept taut during the test.

Examine the metallic wire or metallic component for breakage or hazardous sharp points (8.12, sharpness of points), removing any covering material, if applicable, to aid the examination.

#### **8.13.3 Metallic wires likely to be bent**

Perform the cycle described in 8.13.1 (general) one time.

Examine the metallic wire for breakage or hazardous sharp points (8.12, sharpness of points), removing any covering material, if applicable, to aid the examination.

#### 8.14 Expanding materials (see 4.6)

Condition the toy or component at  $(20 \pm 5) ^\circ\text{C}$  and at a relative humidity of 40 % to 65 % for at least 7 h before the test. Measure the maximum dimensions of the toy or any component of the toy in the x, y and z dimensions using callipers. Submerge the toy or component completely in a container of demineralised water at  $(37 \pm 3) ^\circ\text{C}$  for  $(24 \pm 0,5)$  h. Ensure that sufficient water is used so that the toy or component still remains under water at the end of the test.

Remove the item using a pair of tongs. If the item cannot be removed because of insufficient mechanical strength, it is considered to pass this test.

Allow water adhering to the toy or component to drain for 1 min and re-measure the item.

After re-measuring, repeat the above procedure twice, from the point where the toy or component is submerged in the demineralised water, such that the item has been measured after 24 h, 48 h and 72 h of submergence.

Calculate the expansion in the x, y and z dimensions as a percentage of the original dimension and determine whether it has expanded more than 50 % in any direction after 24 h, 48 h or 72 h.

If the toy fails the requirement in 4.6 after 24 h or 48 h no further testing is required.

#### 8.15 Leakage of liquid-filled toys (see 5.5 and A.42)

Condition the toy at a temperature of  $(37 \pm 1) ^\circ\text{C}$  for 4 h or more.

Within 30 s of removing the toy from conditioning, apply a force of  $5_0^{+0,5}$  N to the external surface of the toy through a steel needle with a diameter of  $(1 \pm 0,05)$  mm and with a tip radius of  $(0,5 \pm 0,05)$  mm.

Apply the force gradually over a period of approximately 5 s. Maintain the force for 5 s.

After completion, examine the toy for leakage of the contents. In determining leakage, apply cobalt-chloride paper over the area where the force was applied while elsewhere compressing with a force of  $5_0^{+0,5}$  N using suitable means other than a needle.

Repeat the test after conditioning the toy at a temperature of  $(5 \pm 1) ^\circ\text{C}$  for 4 h or more.

NOTE Cobalt-chloride paper should not be used after the  $5 ^\circ\text{C}$  test as condensation may give false results.

After completion, visually examine the toy and determine whether leakage of its contents has occurred.

#### 8.16 Geometric shape of certain toys (see 5.8, 5.11 and A.43)

Position and clamp template A shown in Figure 24 so that the axis of the slot is substantially vertical and the slot is unobstructed at its top and bottom openings.

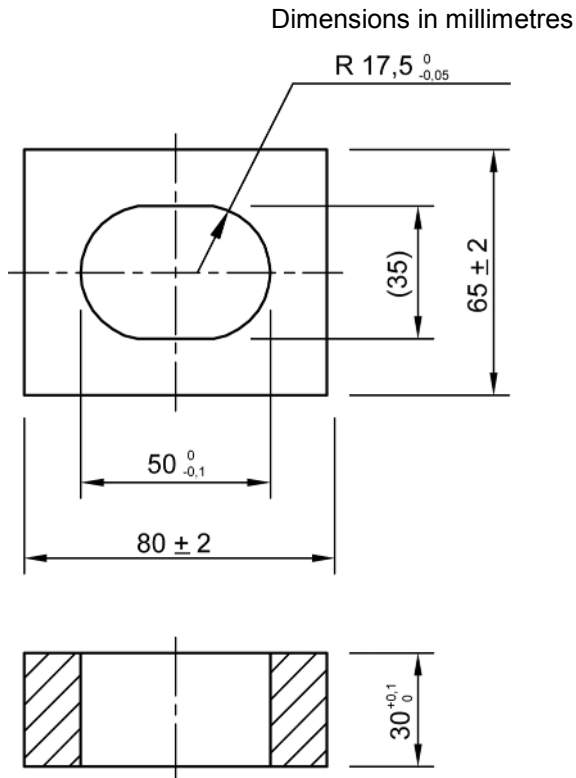

Figure 24 — Template A

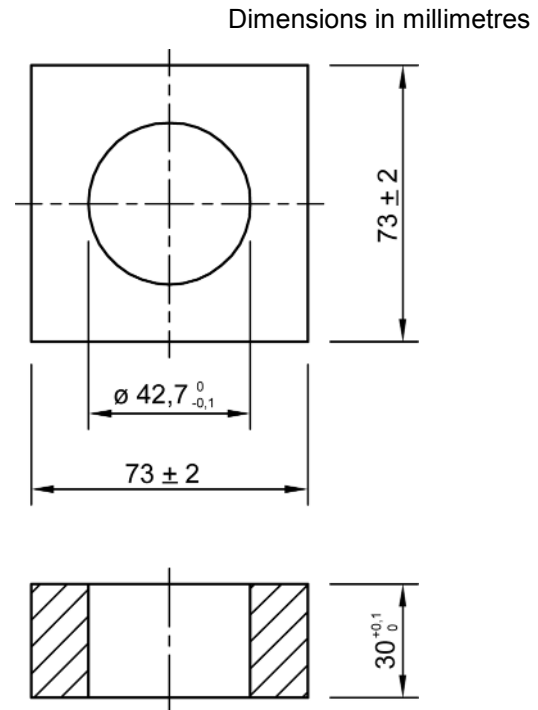

Figure 25 — Template B

Orientate the toy in a position which would most likely permit the entry of the toy through the slot in template A. Place the toy in the slot so that the force on the toy is only the force due to its mass.

Determine whether the toy passes through the slot or whether any part of the toy protrudes past the base of template A.

Repeat the procedure for toys with nearly spherical, hemispherical or circular flared ends using template B shown in Figure 25.

## 8.17 Durability of mouth-actuated toys (see 4.11 and A.44)

### 8.17.1 Mouth-actuated projectile toys

Load the mouth-actuated *projectile* toy with the intended *projectile* and apply a pressure of  $13,8 \text{ kPa} \pm 5 \%$  in the direction of the mouthpiece for 5 s.

Carry out the test 10 times in total.

### 8.17.2 Other mouth-actuated toys

Connect a piston pump capable of discharging and receiving more than  $300 \text{ cm}^3$  of air in less than 3 s to the mouthpiece of the toy. Arrange a relief valve so that the pump will not generate a positive or negative pressure of more than  $13,8 \text{ kPa}$ . Subject the toy to 10 alternating blowing and sucking cycles, each within 5 s and of at least  $(295 \pm 10) \text{ cm}^3$  of air including the volume which may be discharged through the relief valve. If the air outlet is *accessible*, ensure that the above is also applied to the outlet.

Determine whether any released component fits entirely in the small parts cylinder when tested according to 8.2 (small parts cylinder).

## 8.18 Folding or sliding mechanisms (see 4.10.1 and A.45)

### 8.18.1 Loads

Load the toy with a mass of  $(50 \pm 0,5)$  kg.

For toys labelled as not suitable for children of 36 months and over, load the toy with a mass of  $(25 \pm 0,2)$  kg.

The dimensions of the load are given in Figure 26.

Dimensions in millimetres

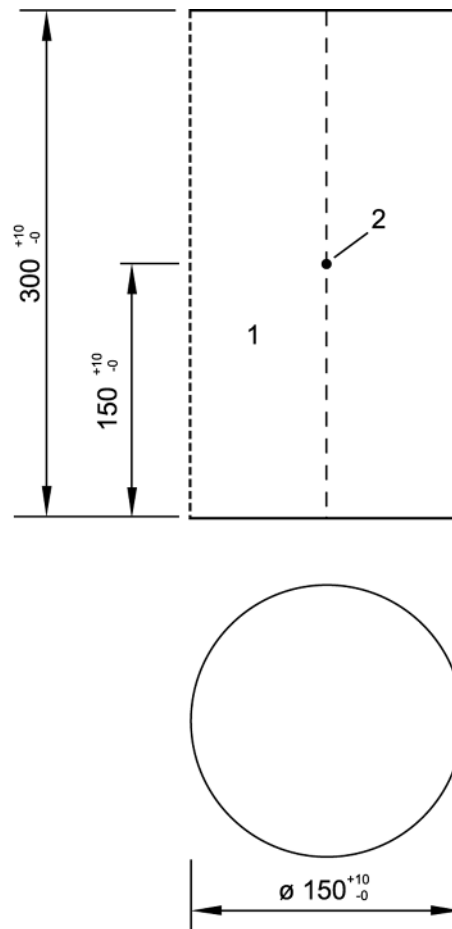

#### Key

- 1 mass, < 36 months, 25 kg  
mass,  $\geq$  36 months, 50 kg
- 2 centre of gravity

Figure 26 — Load for determination of strength and stability

### 8.18.2 Toy pushchairs and perambulators

Precondition the toy by erecting and folding it ten times.

- a) Toy pushchairs and perambulators covered by 4.10.1 a).

Erect the toy on a horizontal surface with the locking devices engaged and load the toy with the appropriate mass ensuring that the load is borne by the frame. Where necessary, use support so that the seat material is not damaged. Apply the load to the frame in the most onerous position with respect to the folding parts. Apply the load for 5 min.

Determine whether it is possible to partially erect the toy without engaging either of the locking devices. If so, also perform the above loading in the partially erect position.

If the seat of the body is detachable from the chassis, this test shall also be performed on the chassis only, using suitable support for the test load.

Determine whether the toy *collapses* and whether the locking devices are still operable and engaged.

b) Toy pushchairs and perambulators covered by 4.10.1 b).

Erect the toy on a horizontal surface with the locking devices engaged and load the toy with the appropriate mass ensuring that the load is borne by the frame. Where necessary, use support so that the seat material is not damaged. Apply the load to the frame in the most onerous position with respect to the folding parts. Apply the load for 5 min.

Determine whether it is possible to partially erect the toy without engaging the locking device. If so, also perform the above loading in the partially erect position.

Determine whether the toy *collapses* and whether the locking device or safety stop is still operable and engaged.

#### **8.18.3 Other collapsible toys (see 4.10.1 c))**

a) Erect the toy. Lift the toy and determine whether the locking device disengages when the toy is tilted in any  $(30 \pm 1)^\circ$  angle from the horizontal.

b) Erect the toy on a surface inclined at  $(10 \pm 1)^\circ$  and in the most onerous position with respect to the folding parts. Engage any locking device. Load the toy for 5 min with the appropriate mass. Apply the load wherever it is possible for a child to sit and in the most onerous position with respect to the folding parts. Ensure that the load is borne by the frame. Where necessary, use support so that the seat material is not damaged (see A.45).

Determine whether the toy *collapses* and whether the locking mechanism disengages.

#### **8.19 Electric resistivity of cords (see 4.13)**

Condition the samples for 7 h or more at a temperature of  $(25 \pm 3)^\circ\text{C}$  and at a relative humidity of 50 % to 65 % and perform the test in this atmosphere.

Determine the electric resistance, using an appropriate appliance.

#### **8.20 Cords cross-sectional dimension (see 5.4 a))**

Whilst under a tension of  $(25 \pm 2)$  N, measure the maximum cross-sectional dimension of the *cord* (see Figure 27) at between three and five points along its length using an instrument capable of measuring in units of 0,1 mm or less. Determine the average cross-sectional dimension to the nearest 0,1 mm. For *cords* approaching 1,5 mm in cross-sectional dimension, use a non-compressible measuring device, e.g. an optical projector.



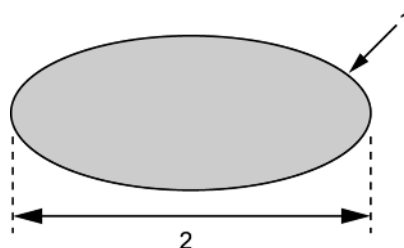

**Key**

- 1 cord transversal section
- 2 cross-sectional dimension

**Figure 27 — Example of measurement of the cross-sectional dimension of a cord**

**8.21 Static strength (see 4.15.1.3, 4.15.1.5, 4.15.3, 4.15.4 and A.46)**

Load the toy in the most onerous position with a mass of  $(50 \pm 0,5)$  kg on its standing or sitting surface for 5 min.

For toys labelled as not suitable for children of 36 months and over, load the toy with a mass of  $(25 \pm 0,2)$  kg.

The dimensions of the load are given in Figure 26.

Where the toy is intended to bear the mass of more than one child at a time, test every sitting or standing area simultaneously.

Toys which due to their design are inherently unstable (e.g. pogo sticks) shall be supported for the duration of the test.

For toys where, by design, the mass of the child is distributed over various positions on the toy, distribute the prescribed load consistent with the recommended use of the toy. In this case, apply other test loads where consideration of the number of distribution points has to be made.

For *toy scooters* the test load shall be positioned in the centre of the platform (see Figure 28).

For *toy scooters* labelled as intended for children with a body mass of 20 kg or less, a test load of  $(50 \pm 0,5)$  kg shall be used.

For other *toy scooters* the test load shall be  $(100 \pm 1)$  kg.

The approximate diameter of the base of the load shall be 150 mm (see Figure 26).

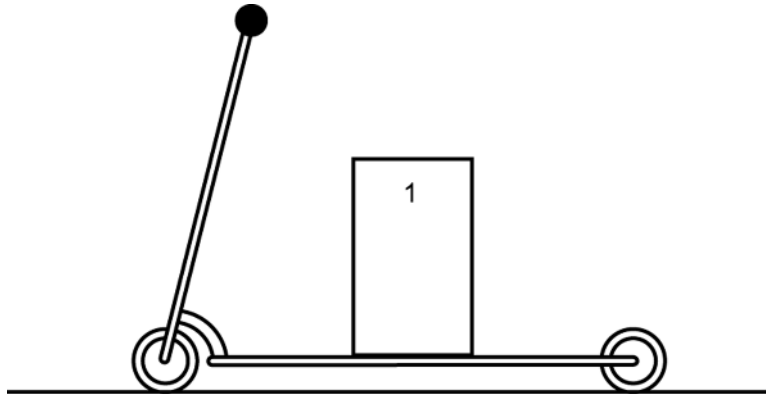

**Key**

1 test load

**Figure 28 — Static strength test for toy scooters**

## 8.22 Dynamic strength (see 4.15.1.3)

### 8.22.1 Principle

A load is secured to the toy, and articulated arms with the elbow joints in a downward position are attached to the steering wheel or handlebars if the toy is so equipped. The toy is driven three times into a non-resilient step.

Determine whether the toy continues to conform to relevant requirements of this European Standard.

### 8.22.2 Loads

Loads as specified in Figure 29, equipped with two articulated arms and a removable cushion with *straps* shall be used.

For toys intended for children of 36 months and over, use load A with a mass of  $(50 \pm 0,5)$  kg.

For toys labelled as unsuitable for children of 36 months and over, use load B with a mass of  $(25 \pm 0,2)$  kg.

The mass of each articulated arm shall be  $(2 \pm 0,02)$  kg.

The mass of the cushion including sand and *straps* shall be  $(0,5 \pm 0,01)$  kg.

The masses of the two articulated arms and the cushion shall be added to the two loads giving a nominal mass of 54,5 kg for load A and 29,5 kg for load B.

The articulated arms shall be attached with spherical joints to the top element diametrically opposite each other, allowing the arms to be moved in any direction.

The joints at the "elbows" move in one direction and shall be capable of being locked. The joints at the "wrists" move in two directions and shall be capable of being locked. The ends of the arms shall be equipped with clamps used for securing the arms to the toy.

### **8.22.3 Procedure**

#### **8.22.3.1 General**

Load the toy on its sitting or standing surface with the appropriate mass in a position that corresponds approximately to the normal use of the toy and secure the load to the toy by means of the *straps*. To prevent undue damage to the toy by the test load, a cushion shall be used but may be omitted if the test load will clearly not cause damage.

Attach the clamps of the articulated arms to the steering wheel or handlebar of the toy in a position that corresponds approximately to the normal use of the toy, and lock the joints at the elbows and the wrists.

Accelerating smoothly, drive the toy three times at a steady speed of  $(2,0 \pm 0,2)$  m/s perpendicularly into a non-resilient step with a height of  $(50 \pm 2)$  mm. The load shall be suspended just after impact in order to prevent it from falling and thereby causing unrelated damage to the toy. For electrically-driven toys, the speed during the test shall be either  $(2,2 \pm 0,2)$  m/s or its maximum design speed, when tested according to 8.29 (determination of maximum design speed of electrically-driven ride-on toys), whichever is the lower.

NOTE 1 During the setting up of the test, adequate precautions for the safe handling of the 50 kg test load should be taken.

NOTE 2 To achieve the suspension and for the safety of the test personnel, it is recommended to connect the load by a wire to an overhead telfer line or similar arrangement.

NOTE 3 A means of constraining the toys should be used in order to assure that the wheel(s) runs into the non-resilient step perpendicularly.

NOTE 4 Stabilizers may be used in order to keep the toy and the load in a vertical position during the test.

If the toy is intended to bear the mass of more than one child at a time, test each sitting or standing surface simultaneously.

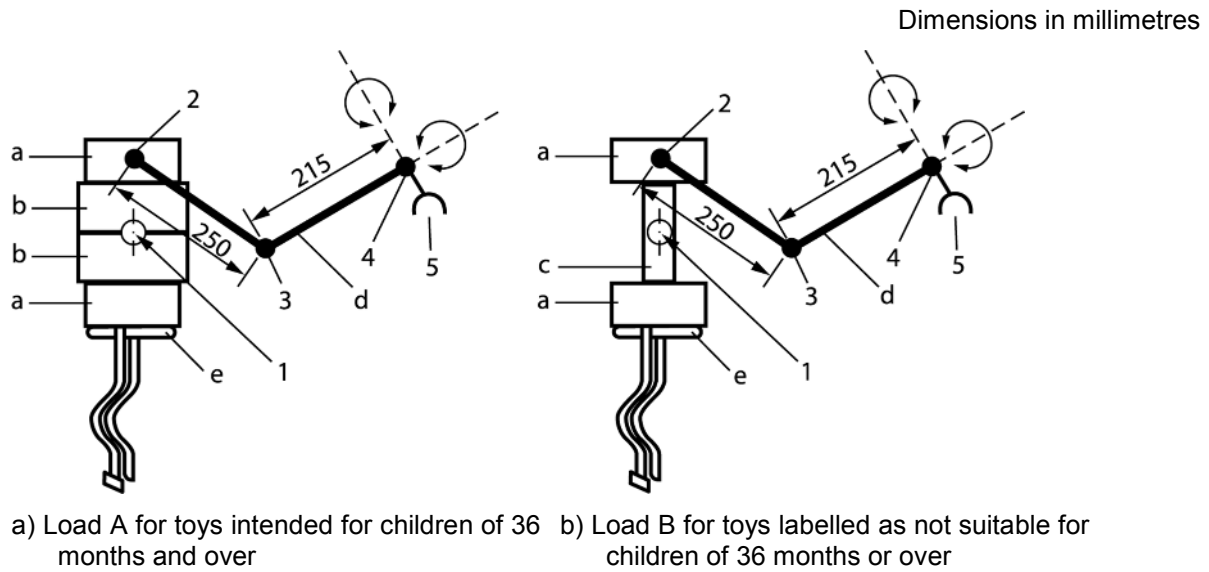

Specification of loads for determination of dynamic strength			
Part	Mass kg	Diameter mm	Height mm
a	10,42	150 ± 2	75 ± 2
b	14,58	178 ± 2	75 ± 2
c	4,16		
d (each)	2,00		
e	0,50		

**Key**

- 1 centre of gravity
- 2 spherical joint
- 3 1-way joint
- 4 2-way joint
- 5 clamp
- d articulated arms
- e cushion with *straps* (removable)

**Figure 29 — Loads for determination of dynamic strength**

**8.22.3.2 Toys intended for use sitting down**

Attach the clamps of the articulated arms to the steering wheel or handlebar of the toy in a position that corresponds approximately to the normal use of the toy, and lock the joints at the elbows and the wrists.

Perform the test as described in 8.22.3.1.

Determine whether the toy continues to conform to relevant requirements of this European Standard.

### 8.22.3.3 Toys intended for use standing

Load the toy on its standing surface with the appropriate mass using a suitable platform with a height of  $(250 \pm 25)$  mm that will place the centre of gravity of the load at a position 400 mm above the standing surface. Secure the load and the platform to the toy by means of *straps*.

The mass of the platform shall be  $(4,8 \pm 0,2)$  kg.

Attach the clamps of the articulated arms to the steering wheel or handlebar of the toy in a position that corresponds approximately to the normal use of the toy, and lock the joints at the elbows and the wrists.

Perform the test as described in 8.22.3.1.

Determine whether the toy continues to conform to relevant requirements of this European Standard.

### 8.22.3.4 Roller skates and toys without steering wheel or handles

For roller skates and toys without steering wheel or handles, secure the articulated arms to the sides of the load. When testing roller skates, the test shall be performed with two roller skates using a suitable bridge to support the load.

Perform the test as described in 8.22.3.1.

Determine whether the toy continues to conform to relevant requirements of this European Standard.

## 8.23 Stability

### 8.23.1 Toys intended to bear the mass of a child (see 4.15.1.4, 4.15.3 and 4.15.4)

Load the toy in the most onerous position with a mass of  $(50 \pm 0,5)$  kg on its standing or sitting surface.

For toys labelled as not suitable for children of 36 months and over, load the toy with a mass of  $(25 \pm 0,2)$  kg.

The dimensions of the load are given in Figure 26.

Place the toy on a  $(10 \pm 1)^\circ$  slope in the most onerous position with respect to stability.

Where the toy is intended to bear the mass of more than one child at a time, test every sitting or standing area reproducing all possible combinations.

Determine whether the toy tips over.

### 8.23.2 Heavy immobile toys (see 4.16)

Place the toy in the most onerous position on a  $(5 \pm 1)^\circ$  slope. Adjust any moving parts so as to produce the most onerous position for stability.

Determine whether the toy tips over.

## 8.24 Determination of kinetic energy (see A.47)

### 8.24.1 Kinetic energy of projectiles (see 4.17.3)

Measure the kinetic energy of the toy under normal conditions of use by a means that is capable of determining the energy to an accuracy of 0,005 J. Take five measurements. Take the kinetic energy as the

maximum of the five readings. Ensure that the readings are taken in such a way that the maximum energy is determined.

If more than one type of *projectile* is supplied with the toy, the kinetic energy of each type of *projectile* shall be measured.

#### **8.24.2 Kinetic energy of bows and arrows (see 4.17.4)**

For bows, use an arrow intended for the bow and stretch the bow string, using a force of 30 N or less, as far as the arrow allows but to no more than 70 cm.

Measure the kinetic energy as specified in 8.24.1.

### **8.25 Plastic sheeting**

#### **8.25.1 Thickness (see 4.3, 5.3 and Clause 6)**

##### **8.25.1.1 Apparatus**

**Measuring device**, capable of measuring thickness to an accuracy of 1 µm according to ISO 4593.

##### **8.25.1.2 Procedure**

For plastic bags, cut along the seams without stretching the bag, so that two single sheets are produced.

Measure the thickness of any sheet at 10 equidistant points across the diagonal of any area having dimensions of at least 100 mm × 100 mm, and average the readings.

#### **8.25.2 Adhesion (see 5.3)**

##### **8.25.2.1 Apparatus**

**Feeler gauge**, with a thickness of  $(0,4 \pm 0,02)$  mm and an insertion *edge* radius of approximately 3 mm (see Figure 19).

##### **8.25.2.2 Procedure**

Using a force of  $(25 \pm 2)$  N, insert the feeler gauge between the component and the underlying layer or body of the toy at any angle between 0° and 10° from the toy surface. The feeler gauge shall be inserted at any place around the component but shall not be inserted at the same place more than 5 times.

Perform the test 30 times.

Determine whether the gauge is inserted more than 2 mm.

### **8.26 Brake performance**

#### **8.26.1 Brake performance for certain ride-on toys (see 4.15.1.5)**

##### **8.26.1.1 General**

Load the toy as in 8.21 (static strength) and place it on a plane inclined at  $(10 \pm 1)^\circ$  covered with a surface of abrasive paper (aluminium oxide P60) with the toy's longitudinal axis parallel to the incline. Apply a force of  $(50 \pm 2)$  N, in the case of levers operated by the hand and arm or by foot, or  $(30 \pm 2)$  N, in the case of levers

operated only by the hand, in the direction in which the brake lever is normally operated. Apply the force to the brake lever 25 mm from the end of the lever.

If the brake is operated by a pedal, apply the force to the pedal in the operating direction to produce the effect of the brake.

If the toy has several brakes, test each brake separately.

Determine whether the toy moves more than 5 cm.

#### **8.26.1.2 Motor brake performance – Ramp test**

Load the toy as in 8.21 (static strength) and place it on a plane inclined at  $(10 \pm 1)^\circ$  covered with a surface of abrasive paper (aluminium oxide P60) with its longitudinal axis parallel to the incline. Allow the toy to roll down the incline. Measure the average speed over a two-metre distance, starting when the toy has travelled one metre from its starting point.

#### **8.26.1.3 Motor brake performance – Horizontal test**

Load the toy as in 8.21 (static strength). Measure the force required to pull the toy on a horizontal plane covered with a surface of abrasive paper (aluminium oxide P60) at a constant speed of  $(2 \pm 0,2)$  m/s.

#### **8.26.2 Brake performance for toy bicycles (see 4.15.2.3)**

Load the *toy bicycle* with a mass of  $(50 \pm 0,5)$  kg, specified in Figure 26, placed vertically on the seat. Place the *toy bicycle* on a plane inclined at  $(10 \pm 1)^\circ$  with its longitudinal axis parallel to the incline.

If the brake is operated by a handle, apply a force of  $(30 \pm 2)$  N at right angles to the axis of the handle, at the middle of the handle.

If the brake is operated by a pedal, apply a force of  $(50 \pm 2)$  N in the operating direction to produce the effect of the brake.

Test each brake separately.

Determine whether the *toy bicycle* moves more than 5 cm.

#### **8.26.3 Brake performance for toy scooters (see 4.15.5.5)**

##### **8.26.3.1 Toy scooters with handbrake**

Load the *toy scooter* as described in 8.22.3.3 using load A, as defined in Figure 29 a), with a nominal mass of 54,5 kg. The platform shall be fitted with adjustable stabilizers in such a way that they allow the *toy scooter* to maintain a vertical position during the test, but such that they are unloaded when the *toy scooter* is in a vertical position. Attach the articulated arms to the handle bar and place the *toy scooter* on a plane inclined at  $(10 \pm 1)^\circ$  covered with a surface of abrasive paper (aluminium oxide P60) and with its longitudinal axis parallel to the incline. Apply a force of  $(30 \pm 2)$  N at right angles to the axis of the brake lever, 25 mm from the end of the lever.

Ensure that the force required to hold the *toy scooter* stationary on the inclined plane, parallel to the plane, is less than 50 N.

NOTE The total test load is 59,3 kg (platform 4,8 kg, mass on platform 50 kg, articulated arms 4 kg, cushion 0,5 kg).

### 8.26.3.2 Toy scooters with foot brake

Load the *toy scooter* as described in 8.22.3.3 using load B, as defined in Figure 29 b), with a nominal mass of 29,5 kg. Apply an additional load with a mass of  $(25 \pm 0,5)$  kg on the foot brake as shown in Figure 30. The platform shall be fitted with adjustable stabilizers in such a way that they allow the *toy scooter* to maintain a vertical position during the test, but such that they are unloaded when the *toy scooter* is in a vertical position. Attach the articulated arms to the handle bar and place the *toy scooter* on a plane inclined at  $(10 \pm 1)^\circ$  covered with a surface of abrasive paper (aluminium oxide P60) and with its longitudinal axis parallel to the incline (see Figure 30).

Ensure that the force required to hold the *toy scooter* stationary on the inclined plane, parallel to the plane, is less than 50 N.

NOTE The total test load is 59,3 kg (platform 4,8 kg, mass on platform 25 kg, mass on foot brake 25 kg, articulated arms 4 kg, cushion 0,5 kg).

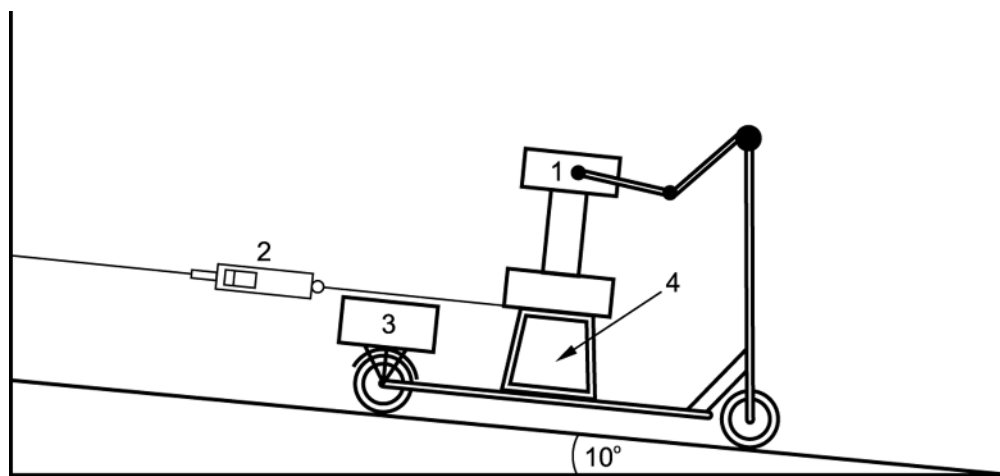

#### Key

- 1 test load,  $(25 \pm 0,2)$  kg, with articulated arms,  $(2 \pm 0,02)$  kg per arm
- 2 dynamometer
- 3 test load,  $(25 \pm 0,5)$  kg
- 4 platform and stabilizers,  $(4,8 \pm 0,2)$  kg, with a platform height of 250 mm

Figure 30 — Brake performance for toy scooters with foot brake

## 8.27 Strength of toy scooter steering tubes (see 4.15.5.3)

### 8.27.1 Resistance to downward forces

Place the *toy scooter* on a horizontal plane and secure it so that it will stand upright during the test. Check that the locking devices are correctly engaged.

- a) For *toy scooters* with two handles, suspend a mass of  $(50 \pm 0,5)$  kg at the centre of each handle (see Figure 31 a)) Maintain the load for 5 min.

Determine whether the steering tube *collapses* and the locking devices are still operable and engaged.

Remove the 50 kg masses. Release one locking device and with the other locking device still engaged, load the handles with a mass of  $(25 \pm 0,2)$  kg each and maintain the load for 5 min.



Determine whether the other locking device is still operable and engaged.

Repeat the test such that both locking devices have been tested.

- b) For *toy scooters* with steering tubes without handles, perform the test as in a) above using a load with a mass of  $(100 \pm 1)$  kg and  $(50 \pm 0,5)$  kg respectively on top of the tube (see Figure 31 b)).

### 8.27.2 Resistance to upward forces

Place and secure the *toy scooter* upside down on a podium (see Figure 31 c)). Check that the locking devices are correctly engaged.

- a) For *toy scooters* with two handles, suspend a mass of  $(25 \pm 0,2)$  kg at the centre of each handle. Maintain the load for 5 min.
- b) For *toy scooters* with steering tubes without handles, place a mass of  $(50 \pm 0,5)$  kg on the end of the steering tube. Maintain the load for 5 min.

Determine whether the steering tube has separated and the locking devices are still operable and engaged.

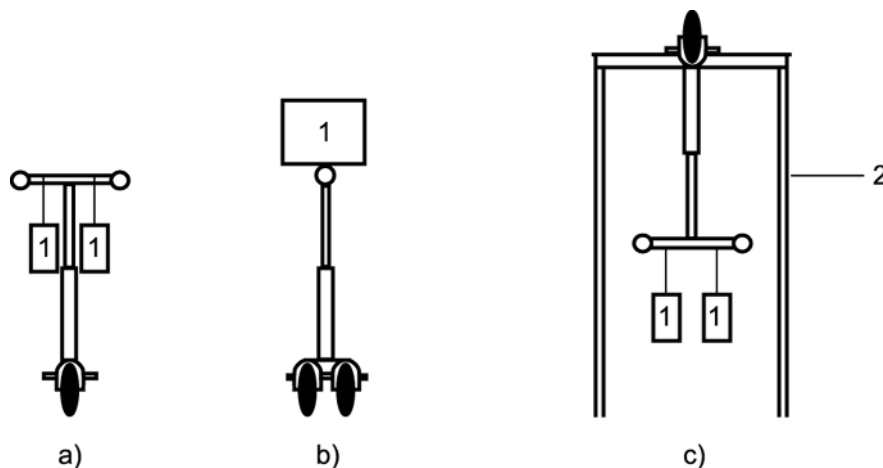

#### Key

- 1 test load  
2 podium

Figure 31 — Test of steering tubes



## 8.28 Determination of emission sound pressure levels (see 4.20)

### 8.28.1 General

#### 8.28.1.1 Principle

The principle is to determine the sound pressure level as it would be in an environment excluding all reflections from walls and ceiling. The operating condition shall be the one yielding the highest A-weighted *time-averaged emission sound pressure level*,  $L_{pA}$ , and the highest C-weighted *peak emission sound pressure level*,  $L_{pCpeak}$ , respectively and the microphone position shall be the one out of a specified set of positions yielding the highest sound pressure level.

NOTE For pull-along or push toys the time-averaged emission sound pressure level,  $L_{pA}$ , is replaced by the maximum emission sound pressure level,  $L_{AFmax}$ .

### **8.28.1.2 Basic test procedure**

Use EN ISO 11201 or EN ISO 11202 and aim for the grade 2 (engineering method) measurement uncertainty. In case of dispute, the more accurate grade 1 of EN ISO 11201 shall be used. When EN ISO 11202 is used the local environmental correction  $K_3$  shall be calculated using the actual distance between source and microphone,  $d$ , and not the minimum distance of 1 m as stated in Annex A of the standard. Earphone and headphone toys shall be tested according to EN 50332-1.

The instrumentation system, including the microphone and cable, shall meet the requirements of a class 1 instrument specified in EN 61672-1. When measuring high *peak emission sound pressure levels*, e.g. from *cap-firing toys*, the microphone and the entire instrumentation system shall have the capability of handling linear peak levels exceeding the C-weighted peak level by at least 10 dB.

### **8.28.1.3 Test conditions**

The tests shall be carried out on a new toy.

Battery toys shall be tested using new non-rechargeable batteries or fully charged rechargeable batteries, whichever is least favourable.

NOTE 1 In general a fully charged rechargeable battery or a new alkaline battery is considered to be the least favourable battery.

Transformer toys shall be tested with the transformer supplied with the toy. If the toy is supplied without a transformer, it shall be tested with a transformer recommended in the instructions.

Toys using both transformers and batteries shall be tested with the least favourable supply allowed by the construction, the type of supply being evaluated for each test.

Clockwork toys shall be fully wound.

Moving toys, where the sound is caused as a result of movement imparted on the toy, shall be tested as *pull-along or push toys*. If the sound of a moving toy is not caused by the movement, the toy shall be tested as *hand-held toys or table-top or floor toys*.

NOTE 2 Examples of moving toys where the sound is not caused as a result of movement include rotating toys hanging from the ceiling or rail-bound trains emitting electronic sound.

Sound reflections caused by test rigs used or the operator shall be minimized.

NOTE 3 Reflections can be minimized by using test rig components (preferably without flat, uncovered surfaces) of dimensions smaller than half a wavelength of the dominant frequencies and by making the operator, whenever possible, stand sideways to the reference box rather than face-on.

Operate the toy in the mode of its intended or foreseeable use which produces the highest sound pressure level relative to the microphone position. The normal measurement time shall be  $(15 \pm 1)$  s. If the toy is sounding during a shorter time than the measurement time, the sound shall be repeated as fast as possible considering a sustainable duration during the measurement time. If needed, the measurement time shall be an integer number of toy sound cycles. For toys with many different operational modes, each lasting less than 15 s, combine these to one long operational cycle. If the toy selects operating conditions randomly increase the number of conditions until a repeatable measurement value is obtained.

Normal operating mode(s) shall be reached before the tests are performed.

Microphone positions that make the toy impossible or impractical to operate shall not be used.

### 8.28.1.4 Test environment

The test environment shall meet the qualification requirements of EN ISO 11201 or EN ISO 11202. Estimate or measure the equivalent sound absorption area in the test room according to EN ISO 3744 or EN ISO 3746. Use Figure 32 to estimate the environmental correction  $K_{2A}$  or  $K_{3A}$  and make sure that it is within the limits given in Table 4.

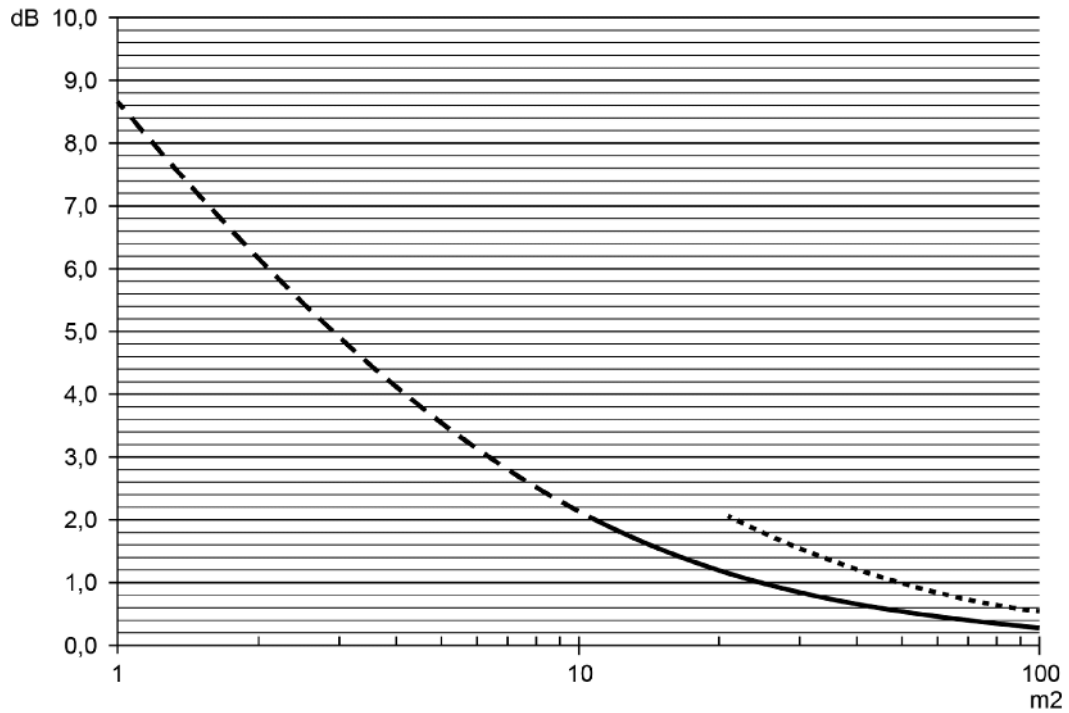

**Key**

- — Local environmental correction according to EN ISO 11202
- ..... Environmental correction  $K_{2A}$  in a free field according to EN ISO 3746
- Environmental correction  $K_{2A}$  in a free field above a reflecting plane according to EN ISO 3746

**Figure 32 — Environmental corrections as a function of the equivalent sound absorption area of the test environment**

Table 4 — Maximum achievable accuracy for different test environments

Standard	Grade of accuracy	Requirement
EN ISO 11201	Grade 1 (Precision)	See EN ISO 3745
EN ISO 11201	Grade 2 (Engineering)	$K_{2A} \leq 2,0$ dB
EN ISO 11202	Grade 2 (Engineering)	$K_{3A} \leq 4$ dB

NOTE If an operator is used, hearing protectors should be used when testing very loud toys.

### 8.28.1.5 Microphone positions

Several microphone positions are prescribed. They shall all be evaluated with respect to finding the position with the highest sound pressure levels but complete measurements are only required for the position yielding these highest levels. Whenever it is practicable, it is always an alternative to rotate the test object instead of moving the microphone. Attention shall be paid to maintaining the correct measuring distance.

For toys mounted in a free field away from reflecting surfaces six microphone positions shall be selected on a box-shaped measurement surface at a measuring distance of 50 cm from the reference box of the toy, as defined in EN ISO 3746 and as specified in Figure 33. The positions are at the centres of the sides of the measurement surface at a distance of  $(50 \pm 1)$  cm from the reference box. Microphone positions that make the toy impossible or impractical to operate shall be disregarded.

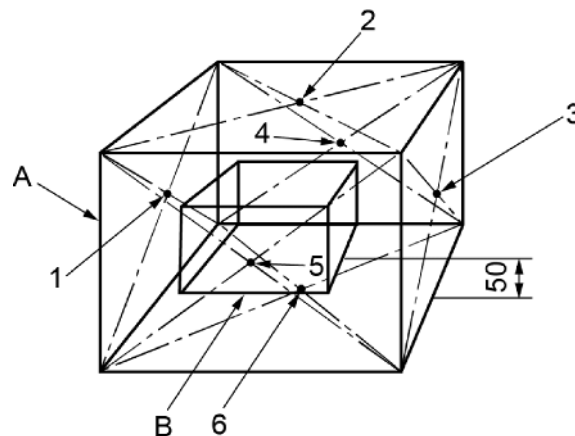

#### Key

- A measurement surface
- B reference box
- 1-6 microphone positions

Figure 33 — Microphone positions for a box-shaped measurement surface in a free field

NOTE 1 It is often convenient to rotate the test object instead of moving the microphone.

NOTE 2 Many distances are defined with respect to the reference box. Parts of the toy not emitting significant sound should, if practicable, be left outside this box. Examples of such typical parts are handles and stands.

Other specific procedures for selection of microphone positions are given in 8.28.2.

### 8.28.1.6 Measurement uncertainty

The total standard uncertainty is given by

$$\sigma_{\text{tot}} = \sqrt{\sigma_{\text{R0}}^2 + \sigma_{\text{omc}}^2}$$

where

$\sigma_{\text{R0}}$  = the standard deviation of the reproducibility of the test method, in decibels

$\sigma_{\text{omc}}$  = the standard deviation describing the instability of the operating and mounting conditions of the toy under test, in decibels

GUM (Guide to the Expression of Uncertainty in Measurement) should be used to calculate  $\sigma_{\text{R0}}$ . As a guidance, the following values are given:

- 1) EN ISO 11201 without meteorological correction at altitudes below 500 m and in a test room qualified according to EN ISO 3745  $\sigma_{\text{R0}} = 0,7$  dB;
- 2) EN ISO 11201 grade 2 using a test room in compliance with grade 2  $\sigma_{\text{R0}} = 1,2$  dB;
- 3) EN ISO 11202 with  $K_{3A} \leq 4$   $\sigma_{\text{R0}} = \sqrt{0,45 + 0,25 \cdot K_{3A}}$  dB.

The above numbers assume class 1 instrumentation and that the background noise is at least 10 dB below the sound to be measured. There is no difference between peak and  $L_{\text{eq}}$  measurements.

$\sigma_{\text{omc}}$  is more complicated as it varies from toy to toy.

In general  $\sigma_{\text{omc}} = 2,0 \pm 1,6$  dB (95 % probability) is a reasonable description. Internal repeatability tests will not give the true round-robin repeatability but can be used as a guidance, in particular for child-actuated toys such as *percussion* toys and *rattles*, where three different operators are used. For other toys the repeatability test is likely to underestimate the round-robin variation of the operating conditions.

In general there is no significant difference in uncertainty between child actuated and other toys. Nor is there any significant difference in uncertainty between measurements of  $L_{\text{pCpeak}}$  and  $L_{\text{pA}}$ .

## 8.28.2 Test procedures

### 8.28.2.1 Close-to-the-ear toys

#### 8.28.2.1.1 Mounting conditions

Mount *close-to-the-ear toys* in a proper test rig at least 100 cm above the reflecting plane, or have them operated by an adult operator with the arm outstretched.

#### 8.28.2.1.2 Microphone positions

Use the box-shaped measurement surface described in Figure 33 with the microphone(s) at a distance of  $(50 \pm 1)$  cm.

#### 8.28.2.1.3 Operating conditions and measurements

If the toy has a clearly defined operating cycle, measure the *time-averaged emission sound pressure level*,  $L_{\text{pA}}$ , in each microphone position during at least one whole cycle. The measurement time shall be  $(15 \pm 1)$  s. If the operating cycle lasts less than 15 s the cycle shall be repeated as quickly as possible and the measurement time shall be adapted to an integer number of operating cycles. If a toy has more than one cycle, each operation cycle may be measured sequentially during one test. Alternatively, one cycle (or combinations of a few cycles) that yields the highest result may be used.

Measure the C-weighted *peak emission sound pressure level* of at least three cycles, using the cycle(s) that yield the highest results.

Repeat the measurement procedure at each microphone position as specified under 8.28.2.1.2 above.

#### 8.28.2.1.4 Measurement results

Record the A-weighted *time-averaged emission sound pressure level*,  $L_{pA}$ , in decibels as the energy average of all measurements taken from the microphone position of the highest energy average.

Record the highest C-weighted *peak emission sound pressure level*,  $L_{pCpeak}$ , in decibels.

#### 8.28.2.2 Table-top or floor toys

##### 8.28.2.2.1 Mounting conditions

Place *table-top or floor toys* on the reflecting plane, if necessary in a test rig so that they can be operated with full power but are prevented from moving around. If holding the toy in position prevents the operation of the toy, e.g. by preventing the rotation of the wheels, the toys should be raised above the reflecting plane, sufficiently to allow operation, but no more than 5 mm.

NOTE Alternatively, the toys may be placed on a standard test table as described in EN ISO 11201.

##### 8.28.2.2.2 Microphone positions

Select five microphone positions on a box-shaped measurement surface at a measuring distance of  $(50 \pm 1)$  cm from the reference box of the toy as specified in Figure 34. If the length or width of the toy is larger than 100 cm, nine microphone positions shall be used by introducing microphone positions at the top four corners of the box-shaped measurement surface. The sides of the measurement box with height  $H$  are always  $(50 \pm 1)$  cm from the sides of the reference box, except for the bottom of the boxes, which lie in the same plane. All microphone positions are on the measurement box. Microphone positions that make the toy impossible or impractical to operate shall be disregarded.

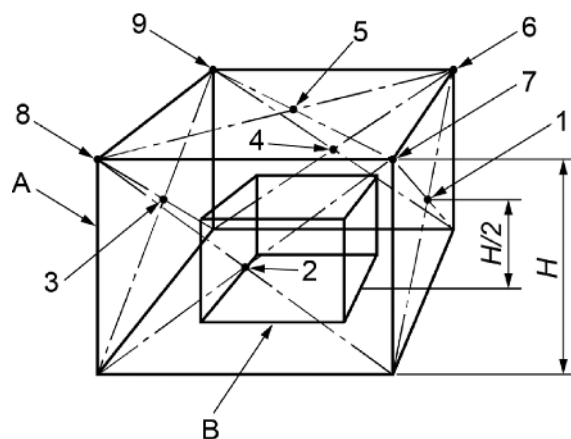

#### Key

- A measurement surface
- B reference box
- 1-5 basic microphone positions
- 6-9 additional microphone positions for large sources
- H height of the box-shaped measurement surface

Figure 34 — Microphone positions for the table-top reference box

### 8.28.2.2.3 Operating conditions and measurements

If the toy has a clearly defined operating cycle, measure the *time-averaged emission sound pressure level*,  $L_{pA}$ , in each microphone position during at least one whole cycle. The measurement time shall be  $(15 \pm 1)$  s. If the operating cycle lasts less than 15 s the cycle shall be repeated as quickly as possible and the measurement time shall be adapted to an integer number of operating cycles. If a toy has more than one cycle then each operation cycle may be measured sequentially during one test. Alternatively one cycle (or combinations of a few cycles) that yield the highest results may be used.

Measure the *peak emission sound pressure level* of at least three cycles, using the cycle(s) that yield the highest results.

Repeat the measurement procedure at each microphone position as specified under 8.28.2.2.2 above.

### 8.28.2.2.4 Measurement results

Record the A-weighted *time-averaged emission sound pressure level*,  $L_{pA}$ , in decibels as the energy average of all measurements taken from the microphone position of the highest energy average.

Record the highest C-weighted *peak emission sound pressure level*,  $L_{pCpeak}$ , in decibels.

## 8.28.2.3 Hand-held toys

### 8.28.2.3.1 Mounting conditions

Mount *hand-held toys* in a proper test rig at least 100 cm above the reflecting plane, or have them operated by an adult operator with the arm outstretched.

### 8.28.2.3.2 Microphone positions

Use the box-shaped measurement surface as defined in Figure 33 with the microphone(s) at a distance of  $(50 \pm 1)$  cm.

### 8.28.2.3.3 Operating conditions and measurements

If the toy has a clearly defined operating cycle, measure the *time-averaged emission sound pressure level*,  $L_{pA}$ , in each microphone position during at least one whole cycle. The measurement time shall be  $(15 \pm 1)$  s. If the operating cycle lasts less than 15 s the cycle shall be repeated as quickly as possible and the measurement time shall be adapted to an integer number of operating cycles. If a toy has more than one cycle then each operation cycle may be measured sequentially during one test. Alternatively one cycle (or combinations of a few cycles) that yield the highest results may be used.

Measure the *peak emission sound pressure level* of at least three cycles, using the cycle(s) that yield the highest results.

Repeat the measurement procedure at each microphone position specified in 8.28.2.3.2.

### 8.28.2.3.4 Measurement results

Record the A-weighted *time-averaged emission sound pressure level*,  $L_{pA}$ , in decibels as the energy average of all measurements taken from the microphone position of the highest energy average.

Record the highest C-weighted *peak emission sound pressure level*,  $L_{pCpeak}$ , in decibels.

## 8.28.2.4 Toys with earphones and headphones

### 8.28.2.4.1 Mounting

Mount earphones and headphones on a Head and Torso Simulator (HATS) according to IEC/TS 60318-7. Alternatively intra-concha and supra aural earphones may also be mounted in an occluded ear simulator according to EN 60318-4 together with an ear canal extension and pinna as described in IEC/TS 60318-7.

NOTE This alternative method includes a less accurate mounting and will thus yield a less accurate result. Whenever possible it is recommendable to use a HATS.

### 8.28.2.4.2 Microphone positions

Use the devices as described in 8.28.2.4.1 above.

### 8.28.2.4.3 Operating conditions and measurements

Measure the A-weighted *time-averaged emission sound pressure level*,  $L_{pA}$ , according to EN 50332-1.

Measurement of C-weighted *peak emission sound pressure level*,  $L_{pC\ peak}$ , is not defined in EN 50332-1, but shall be made in the same manner as the A-weighted *emission sound pressure level* measurement.

### 8.28.2.4.4 Measurement results

Record the A-weighted *time-averaged emission sound pressure level*,  $L_{pA}$ , in decibels and the C-weighted *peak emission sound pressure level*,  $L_{pC\ peak}$ , in decibels converted to free field equivalent levels.

The free field C-weighted *peak emission sound pressure level* shall be determined by subtracting 10 dB from the value measured in the coupler. The free field A-weighted *time-averaged emission sound pressure level* shall be determined using the field response data of the HATS, ear simulator or ear coupler provided by the manufacturer, otherwise the 0° free field response given in IEC/TS 60318-7 shall be used.

## 8.28.2.5 Rattles

### 8.28.2.5.1 Mounting

*Rattles* shall be operated by an adult operator with the forearm essentially horizontal at the same height as the microphone, standing side-face with the microphone with the *rattle* at the same height as the microphone at a distance of 50 cm.

### 8.28.2.5.2 Microphone positions

Mount the microphone at least 100 cm above the floor and at a distance of  $(50 \pm 1)$  cm from the nearest vertical plane in which the *rattle* is shaken.

### 8.28.2.5.3 Operating conditions and measurements

For *rattles* or other types of toy intended to be similarly shaken, use a movement of approximately 15 cm. Operate a *rattle* by grasping it where it is meant to be held or, if in doubt, where the longest lever can be obtained between the hand and the sound emitting part of the *rattle*. Ensure that the radiated sound is not affected by the grip of the hand. Strike downward with hard lashes. Use the wrist and keep the forearm essentially horizontal. Stand side-face with the microphone and keep the *rattle* at the same height as the microphone at a distance of  $(50 \pm 1)$  cm (i.e. the *rattle* shall be shaken at a constant distance from the microphone and not towards and away from the microphone).

Use three adult operators.



For *peak emission sound pressure level* measurements, for each operator, strike downwards 10 times in a slow tempo yielding the highest C-weighted peak sound pressure level for each strike.

For  $L_{pA}$ -measurements measure during  $(15 \pm 1)$  s using the tempo yielding the highest time-averaged sound pressure level. Each operator shall produce at least three samples of the intended sound. If needed, for each operator, increase the number of samples until the maximum difference, in dB, between any two samples is less than the number of samples.

#### 8.28.2.5.4 Measurement results

Record the A-weighted *time-averaged emission sound pressure level*,  $L_{pA}$ , in decibels as the energy average of all measurements taken. Subtract 5 dB from the measured  $L_{pA}$  before comparing the measured value with the limit value.

Record the highest C-weighted *peak emission sound pressure level*,  $L_{pCpeak}$ , in decibels.

#### 8.28.2.6 Squeeze toys

##### 8.28.2.6.1 Mounting

*Squeeze toys* shall be operated by an adult operator with the arm outstretched, standing directly in front of the microphone. The air exit hole shall be at a distance of 50 cm from the microphone and directed towards the microphone. The microphone shall be at the same height as the *squeeze toy*.

##### 8.28.2.6.2 Microphone positions

Mount the microphone at least 100 cm above the floor and at a distance of  $(50 \pm 1)$  cm from the air exit hole of the *squeeze toy*.

##### 8.28.2.6.3 Operating conditions and measurements

Operate a squeeze toy by grasping the toy with both hands, if feasible, otherwise by one hand, and holding it where it is meant to be held or, if in doubt, where the highest sound level can be achieved. Squeeze, if possible, with both thumbs to achieve the highest possible sound level. Use three adult operators.

For *peak emission sound pressure level* measurements, for each operator, squeeze 10 times using the tempo yielding the highest C-weighted peak sound pressure level for each squeeze.

For  $L_{pA}$ -measurements measure during  $(15 \pm 1)$  s using the tempo yielding the highest time-averaged sound pressure level. Each operator shall produce at least three samples of the intended sound. If needed, for each operator, increase the number of samples until the maximum difference, in dB, between any two samples is less than the number of samples.

##### 8.28.2.6.4 Measurement results

Record the A-weighted *time-averaged emission sound pressure level*,  $L_{pA}$ , in decibels as the energy average of all measurements taken. Subtract 5 dB from the measured  $L_{pA}$  before comparing the measured value with the limit value.

Record the highest C-weighted *peak emission sound pressure level*,  $L_{pCpeak}$ , in decibels.

### 8.28.2.7 Pull-along or push toys

#### 8.28.2.7.1 Mounting

Place *pull-along or push toys* on the reflecting plane and fix them in a test rig enabling them to be moved with varying speed along a direct line which passes the measuring microphones ("pass-by test"). Make sure that the reflecting plane offers sufficient friction to prevent wheels from skidding.

#### 8.28.2.7.2 Microphone positions

Dimensions in centimetres

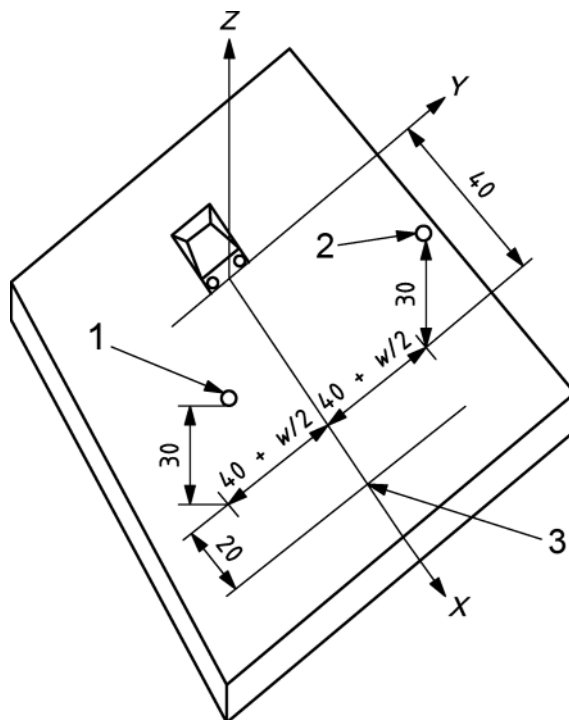

#### Key

- 1-2 microphones
- 3 end of measurement
- w width of toy

**Figure 35 – Microphone positions for the measurement of pull-along or push toys**

Use two microphones placed 30 cm above the reflecting plane ( $40 + w/2$ ) cm from the X-axis as shown in Figure 35.

Place the toy on a test rig or on the reflecting plane in its normal operating orientation in such a way that movement of the toy is possible along the x-axis passing the microphone positions.

#### 8.28.2.7.3 Operation conditions and measurements

Operate *pull-along or push toys* at a speed of 1 m/s or less, whichever yields the maximum sound pressure level. Measure the A-weighted *maximum emission sound pressure level* with time-weighting F and the C-weighted *peak emission sound pressure level* on each side for each of two pass-bys.

#### 8.28.2.7.4 Measurement results

Record the highest A-weighted *maximum emission sound pressure level* with time-weighting F,  $L_{pAFmax}$ , of the two sides and the two pass-bys, in decibels.

Record the highest C-weighted *peak emission sound pressure level*,  $L_{pCpeak}$ , of the two sides and the two pass-bys, in decibels.

#### 8.28.2.8 Percussion toys

##### 8.28.2.8.1 Mounting conditions

Mount *percussion toys* using the most appropriate of the following:

- On the table or reflecting plane, for *percussion toys* intended to be used on a table;
- At arm's length using an adult tester, for *percussion toys* intended to be hand held;
- Hanging around the neck/waist of an adult user, for toys intended to be hung around the neck/waist.

##### 8.28.2.8.2 Microphone positions

For *hand-held toys* use the box-shaped measurement surface defined in Figure 33 with the microphone(s) at a distance of 50 cm. For *table-top or floor toys* use the box-shaped measurement surface defined in Figure 34.

##### 8.28.2.8.3 Operation conditions and measurements

Strike the toy with one beater holding the beater such that the longest lever can be obtained. Strike the surface intended to be struck, with hard lashes. If no beater is supplied strike the surface of the toy intended to be struck with the hand. The hand should be positioned so that the maximum sound is generated. Ensure that the radiated sound is not affected by the beater or hand after striking.

Mount drums hanging horizontally and beat the upper surface (i.e. the surface intended to be hit). When playing xylophones beat all plates equally much.

Use three adult operators.

For *peak emission sound pressure level* measurements, for each operator, strike 10 times using the tempo yielding the highest C-weighted peak sound pressure level for each strike.

For  $L_pA$ -measurements measure during  $(15 \pm 1)$  s using the tempo yielding the highest time-averaged sound pressure level. Each operator shall produce at least three samples of the intended sound. If needed, for each operator, increase the number of samples until the maximum difference, in dB, between any two samples is less than the number of samples.

##### 8.28.2.8.4 Measurement results

Record the A-weighted *time-averaged emission sound pressure level*,  $L_{pA}$ , in decibels as the energy average of all measurements taken from the microphone position of the highest energy average. Subtract 10 dB from the measured  $L_{pA}$  before comparing the measured value with the limit value.

Record the highest C-weighted *peak emission sound pressure level*,  $L_{pCpeak}$ , in decibels.

### **8.28.2.9 Wind toys**

#### **8.28.2.9.1 Mounting conditions**

*Wind toys* shall be tested while in the mouth of an adult tester.

#### **8.28.2.9.2 Microphone positions**

Use the box-shaped measurement surface specified in Figure 33, each position located at a distance 50 cm excluding the position behind the blowing person.

#### **8.28.2.9.3 Operating conditions and measurements**

Operate wind toys with three different adult operators. Each operator shall be standing away from other reflecting obstacles.

For *peak emission sound pressure level* measurements, for each operator, produce three samples of the intended sound in each microphone position by blowing to achieve the highest possible C-weighted sound pressure level.

For  $L_{pA}$ -measurements blow to achieve the highest possible A-weighted time-averaged sound pressure level. Each operator shall produce at least three samples of the intended sound in each microphone position. If needed, for each operator, increase the number of samples until the maximum difference, in dB, between any two samples is less than the number of samples.

#### **8.28.2.9.4 Measurement results**

Record the A-weighted *time-averaged emission sound pressure level*,  $L_{pA}$ , in decibels as the energy average of all measurements taken from the microphone position of the highest energy average. Subtract 5 dB from the measured  $L_{pA}$  before comparing the measured value with the limit value.

Record the highest C-weighted *peak emission sound pressure level*,  $L_{pCpeak}$ , in decibels.

### **8.28.2.10 Cap-firing toys**

#### **8.28.2.10.1 Mounting conditions**

Mount *cap-firing toys* in a proper test rig at least 100 cm above the reflecting plane, or have them operated by an adult operator with the arm outstretched.

#### **8.28.2.10.2 Microphone positions**

For cap-guns use 6 microphone positions around the toy. Place the main sound emitting part of the toy at the origin of the measuring coordinate system in its normal operating orientation in such a way that the main axes of the toy coincide with the axes of the coordinate system (See Figure 36). If the length of the toy exceeds 50 cm, rotate the toy in the xy-plane 45° around the z-axis without changing the microphone positions. Select two microphone positions along each axis at a distance of  $(50 \pm 1)$  cm to both directions from the toy.

Dimensions in centimetres

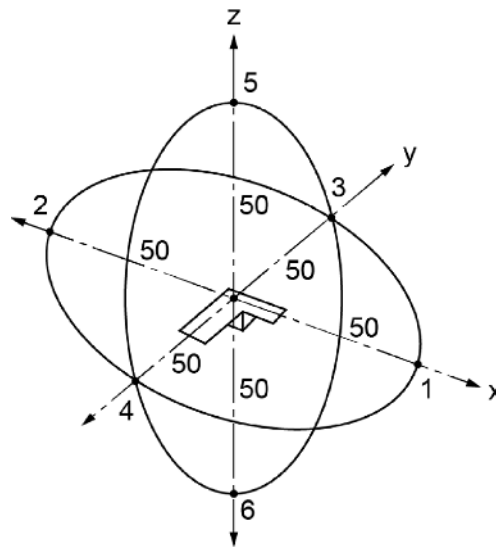

**Key**

1-6 microphone positions

**Figure 36 – Microphone positions for the measurement of the emission sound pressure levels of cap guns**

For other *cap-firing* toys use the reference box as defined in 8.28.1.5 with the microphone(s) at a distance of 50 cm.

**8.28.2.10.3 Operating conditions and measurements**

For measurement of the C-weighted *peak emission sound pressure level* fire the gun at least 3 times in each microphone position to find the position with the highest peak sound pressure level. Then fire additionally 6 times in the position with the highest peak sound pressure level.

For measurement of the A-weighted *time-averaged emission sound pressure level*,  $L_{pA}$ , fire the gun with highest possible frequency for at least 10 s. If the gun has to be reloaded during the measurement time for loading at normal speed it shall be included in the measurement time. Repeat the test three times. Carry out the test in the position with the highest C-weighted peak sound pressure level.

**8.28.2.10.4 Measurement results**

Record the A-weighted *time-averaged emission sound pressure level*,  $L_{pA}$ , in decibels as the energy average of all measurements taken from the microphone position of the highest energy average.

Record the highest C-weighted *peak emission sound pressure level*,  $L_{pCpeak}$ , in decibels.

**8.28.2.11 Voice toys**

**8.28.2.11.1 Mounting conditions**

Operate voice toys set at maximum output level by placing the microphone unit of the toy at the most suitable distance within the range 5 cm to 50 cm in front of a wideband loudspeaker emitting programme simulating noise as defined in EN 50332-1. Loudspeaker and noise may be limited to the frequency range 200 Hz to 4000 Hz. Gradually increase the output level of the wideband loudspeaker until the output level of the toy is no longer increasing. If the loudspeaker level is increased in steps, the steps shall not be larger than 5 dB. Feedback sound shall not be considered.

Walkie talkies are measured with the source apparatus and the loudspeaker in one room and with the receiving apparatus in another room. Toys with recording capacity are measured with the programme simulating noise switched off while playing the recorded noise. Bull horns are first measured with the bull horn switched off and then with both programme simulating noise and bull horn switched on.

#### **8.28.2.11.2 Microphone positions**

For *voice toys* intended to be used on the floor or on a table use the microphone positions as specified in 8.28.2.2.2, and for *voice toys* intended to be hand-held use the microphone positions as specified in 8.28.2.3.2 or use the most appropriate microphone positions according to the other toy types.

#### **8.28.2.11.3 Operating conditions and measurements**

Operate *voice toys* by placing the microphone unit of the toy in front of a wideband loudspeaker emitting programme simulating noise as defined in EN 50332-1. Gradually increase the output level of the loudspeaker until the output level of the toy is no longer increasing. If the loudspeaker level is increased in steps, the steps shall not be larger than 5 dB. Feed-back sound shall not be considered.

#### **8.28.2.11.4 Measurement results**

Record the A-weighted *time-averaged emission sound pressure level*,  $L_{pA}$ , in decibels as the energy average of all measurements taken from the microphone position of the highest energy average.

Record the highest C-weighted *peak emission sound pressure level*,  $L_{pCpeak}$ , in decibels.

For bull horns and other toys which are measured with output from both the toy and the wide band loudspeaker simultaneously, the A-weighted *time averaged emission sound pressure level* of the toy,  $L_{pA}$ , is given by

$$L_{pA} = 10 \lg(10^{0,1L_1} - 10^{0,1L_2}) \text{ dB}$$

where

$L_1$  = measured A-weighted *time averaged emission sound pressure level* with both toy and loudspeaker emitting programme simulating noise in operation simultaneously,

$L_2$  = measured A-weighted *time averaged emission sound pressure level* with toy switched off and only loudspeaker emitting programme simulating noise in operation.

If  $L_1 - L_2 < 3$  dB,  $L_{pA}$  cannot be calculated. In that case the result shall be given as  $L_{pA} < L_1$  dB.  $\triangleleft 2$

### **8.29 Determination of maximum design speed of electrically-driven ride-on toys (see 4.15.1.2, 4.15.1.5, 4.15.1.8 and 5.6)**

For electrically-driven ride-on toys labelled as not suitable for children of 36 months and over, load the toy with a mass of  $(25 \pm 0,2)$  kg on its sitting or standing surface.

For all other electrically-driven ride-on toys, load the toy with a mass of  $(50 \pm 0,5)$  kg.

If the toy is intended to bear the mass of more than one child at a time, place the mass on the driver's sitting or standing surface.

The dimensions of the load are given in Figure 26.

Ensure that the battery is fully charged according to the instructions for use.

Operate the toy on a horizontal plane with a surface that prevents skidding of the wheels (e.g. abrasive paper, asphalt or similar), with any speed control at its highest setting. If the toy is equipped with a two-position device with which the maximum design speed can be changed, the speed shall be determined with the device in the low-speed position and in the high-speed position.

Determine the average speed with an accuracy of  $\pm 10\%$ .

Carry out the test three times and determine the maximum value.

The maximum design speed is the determined maximum value.

### **8.30 Measurement of temperature rises (see 4.21)**

In an ambient temperature of  $(20 \pm 5)^\circ\text{C}$ , operate the toy according to the instructions for use at the maximum input until equilibrium temperature is reached.

Measure the temperature of the *accessible* parts and calculate the temperature rises.

Determine whether the toy ignites.

### **8.31 Toy chest lids (see 4.14.1 c))**

#### **8.31.1 General**

The lid shall be assembled according to the manufacturer's instructions before testing.

#### **8.31.2 Lid support**

Lift the lid to any position in its arc of travel to a distance greater than 50 mm from its fully closed position measured at the outermost *edge* of the lid, but not to cause the lid to move through an arc of more than  $60^\circ$ . Release the lid and measure any dropping motion at a point in the approximate centre of the outermost *edge* of the lid.

Determine whether the lid drops more than 12 mm.

#### **8.31.3 Durability test for vertically opening hinged lids**



Subject the lid to 7 000 opening and closing cycles. One cycle consists of raising the lid from its fully closed position to fully open and returning it to fully closed. To prevent undue stress on screws or other *fastenings* used to attach the lid support mechanism, care should be taken not to force the lid beyond its normal arc of travel.

The time to complete one cycle shall be approximately 15 s. The 7 000 cycles shall be completed within a period of 72 h, after which the test described in 8.31.2 (lid support) shall be repeated.

Determine whether the toy chest lid and the lid support mechanism continues to conform to relevant requirements of this European Standard.

### **8.32 Small balls and suction cups test (see 4.17, 4.22, 4.25, 5.10 and 5.13)**

#### **8.32.1 Small balls and suction cups (see Clause 6)**

Position and clamp template E shown in  Figure 37  so that the axis of the slot is substantially vertical and the slot is unobstructed at its top and bottom openings.

Place the *ball* or the *suction cup* or the toy with an attached *suction cup* without compressing it, in any orientation in the slot so that the force on the *ball* or *suction cup* or toy with an attached *suction cup* is only the force due to its mass.

Determine whether the *ball* or *suction cup* or toy with an attached *suction cup* passes entirely through template E.

Dimensions in millimetres

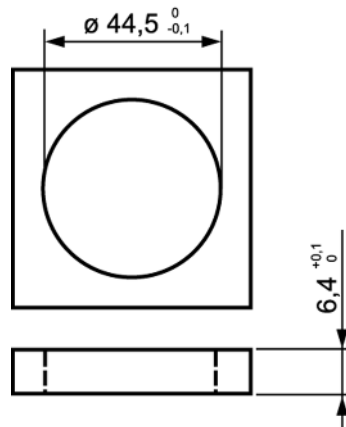

Ⓐ

Figure 37 Ⓐ — Template E

### 8.32.2 Small balls attached to a toy by a cord

Position and clamp template E shown in Ⓐ Figure 37 Ⓐ so that the axis of the slot is substantially vertical and the slot is unobstructed at its top and bottom openings.

Suspend the *ball* by the toy and its *cord* and lower the *ball*, without compressing it, into the slot so that the force on the *ball* is only its force due to its mass. Before the distance A is measured, the *ball* shall be lowered as far as the *cord* and the attached toy allow (see Ⓐ Figure 38 Ⓐ).

Determine whether the *ball* passes through the base of template E such that the distance A indicated in Ⓐ Figure 38 Ⓐ is greater than 30 mm. The distance A shall be measured from the top of the template to the intersection point of the major and minor axes of the *ball*.



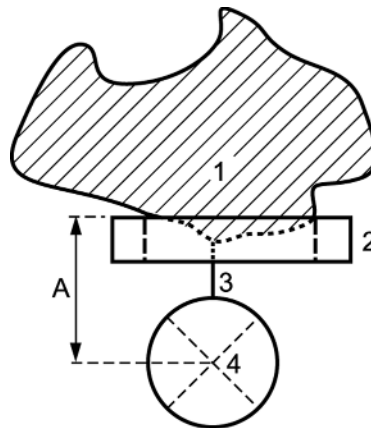

**Key**

- 1 toy
- 2 template E
- 3 cord
- 4 intersection point of the major and the minor axes

**A<sub>2</sub>**

**Figure 38 **A<sub>2</sub>** — Example of test of a ball attached to a toy by a cord**

**8.33 Test for play figures (see 5.11)**

Position and clamp template B shown in Figure 25 so that the axis of the slot is substantially vertical and the slot is unobstructed at its top and bottom openings.

Orientate the play figure in a position which would most likely permit the entry of the rounded end through the slot in the template. Place the toy in the slot so that the force on the toy is only the force due to its mass.

Determine whether the rounded end of the play figure protrudes past the base of template B.

**8.34 Tension test for magnets (see 4.23.2 and A.51)**

**8.34.1 General**

Either a magnet or a *magnetic component*, or a reference disc (see 8.34.3.1), is used in order to test whether an *accessible* but not grippable magnet in the toy can be detached by a magnetic pulling force.

The test shall simulate the intended or a reasonably foreseeable play pattern.

If, for toys that contain more than one magnet or *magnetic component*, the test specified in 8.34.2 cannot be carried out without damaging the toy, the *accessible* but non-grippable magnets in the toy shall instead be tested in accordance with 8.34.3.

NOTE An example of a case where 8.34.2 is not possible to perform without damaging the toy could be a toy figurine with one *accessible* but non-grippable magnet in each foot.

**8.34.2 Toys that contain more than one magnet or magnetic component**

Identify the magnet or *magnetic component* in the toy that is most likely to be able to detach the magnet that is to be subjected to the tension test.

Without damaging the toy, place the magnet or *magnetic component* as close as possible to the magnet to be tested. Gradually apply a pulling force to the magnet/*magnetic component* until it separates from the tested magnet or until the magnet is detached from the toy. Perform the test 10 times.

Repeat the procedure for any other magnet that according to 4.23.2 shall be subjected to the tension test for magnets.

NOTE If it is not possible to determine which magnet or *magnetic component(s)* in the toy that is most likely to be able to detach the magnet that is to be subjected to the test, it is permissible to repeat the test with another magnet or *magnetic component* from the toy.

### **8.34.3 Toys that contain one magnet only**

#### **8.34.3.1 Apparatus**

A nickel disc with a minimum nickel content of 99 %, and having the following dimensions:

- diameter ( $30 \pm 0,5$ ) mm;
- length ( $10 \pm 0,5$ ) mm.

#### **8.34.3.2 Procedure**

Without damaging the toy, place the flat part of the nickel disc as close as possible to the magnet to be tested.

Gradually apply a pulling force to the disc until it separates from the magnet or until the magnet is detached from the toy. Perform the test 10 times.

### **8.35 Magnetic flux index (see 4.23.2 and 4.23.3)**

#### **8.35.1 General**

The magnetic flux index is calculated based on the results from measurements of the flux density and the pole surface area.

#### **8.35.2 Apparatus**

**A1**

**8.35.2.1 Direct current field Gauss meter** with a resolution of 5 G, and capable of determining the field to an accuracy of 1,5 % or better. **A1**

The meter shall have an axial type probe manufactured with

- an active area diameter of ( $0,76 \pm 0,13$ ) mm;
- a distance between the active area and probe tip of ( $0,38 \pm 0,13$ ) mm.

**8.35.2.2 Calliper square** or similar device capable of determining dimensions to an accuracy of 0,1 mm.

### 8.35.3 Procedure

#### 8.35.3.1 Measurement of flux density

Place the tip of the Gauss meter's probe in contact with the pole surface of the magnet. For a *magnetic component* (where the magnet is fully or partially imbedded in part of the toy), place the tip of the probe in contact with the surface of the component.

Maintain the probe in a position perpendicular to the surface.

Move the probe across the surface to locate the maximum flux density.

Record the maximum flux density.

#### 8.35.3.2 Measurement and calculation of the pole surface area

If the magnet is imbedded/attached as part of a *magnetic component*, extract the magnet from the component even if it is necessary to break the toy.

If the pole is not flat (for example, hemispherical), measure the maximum diameter of the magnet perpendicular to an axis through the magnet poles (see  $\text{A}_2$  Figure 39  $\text{A}_2$ ), with an accuracy of  $\pm 0,1$  mm and calculate the area of the corresponding cross-section.

If the pole surface of the magnet is flat, measure the dimensions with an accuracy of  $\pm 0,1$  mm and calculate the area using the appropriate geometric formula.

For multi-pole magnets measure and calculate the area of the largest single pole, which can be identified using magnetic field viewing film or equivalent.

NOTE An example of multi-pole magnet is a rubberized/plastoferrite magnet, consisting of multiple strips of poles.

### 8.35.4 Calculation of magnetic flux index

The flux index ( $\text{kG}^2 \text{mm}^2$ ) is calculated by multiplying the calculated area of the pole surface ( $\text{mm}^2$ ) of the magnet by the square of the maximum flux density ( $\text{kG}^2$ ).

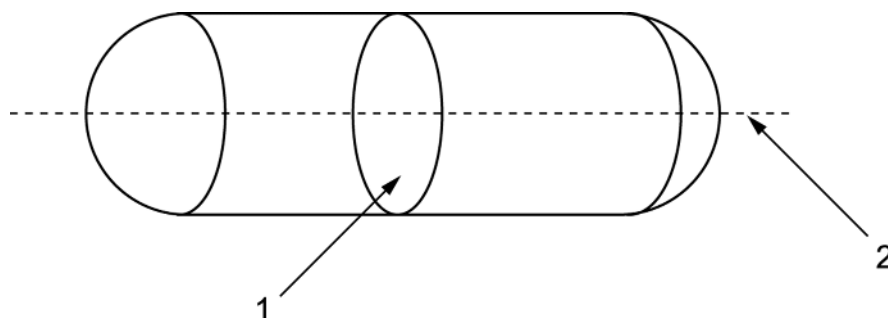

#### Key



- 1 maximum cross-section perpendicular to the axis
- 2 axis through the magnet poles

$\text{A}_2$

Figure 39  $\text{A}_2$  — Maximum diameter of magnet with a non-flat pole

### 8.36 Perimeter of cords and chains (see 5.4 c) and 5.4 d))

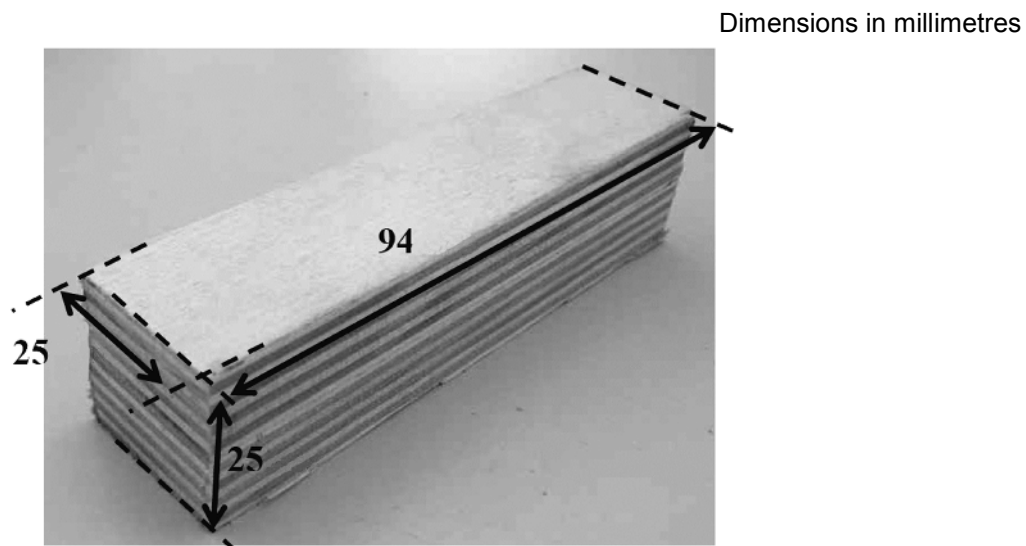

#### 8.36.1 Test equipment

Test blocks: two rectangular test blocks made of rigid, smooth material (wood is acceptable) with dimensions  $(94 \pm 1) \text{ mm} \times (25 \pm 1) \text{ mm} \times (25 \pm 1) \text{ mm}$  (see  Figure 40 .





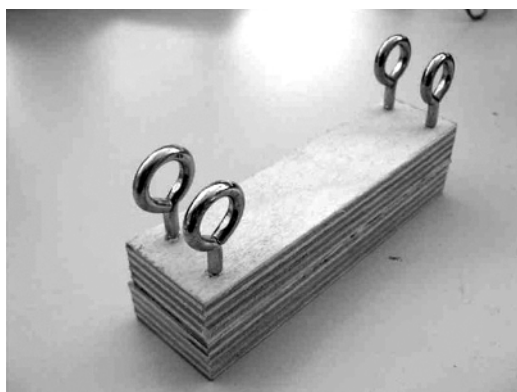

**Figure 40  — Test blocks dimensions**

One of the test blocks shall be equipped, at its corners, with a suitable means to attach a *cord* (e.g. holes, screws) (see  Figure 41 .





**Figure 41  — Example of suitable cord fixing means**

Two inelastic *cords* shall be attached to this test block as shown in  Figure 42 .

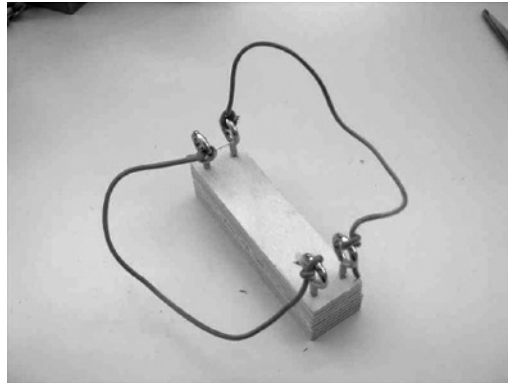

A<sub>2</sub>

Figure 42 A<sub>2</sub> — Example of test block fitted with cords

The length of the two *cords* shall be such that, when they are tensioned with a force of  $(25 \pm 2)$  N at their centres, the distance from the centre of the *cord* to the upper surface of the test block is approximately 0,1 m (see A<sub>2</sub> Figure 45 and Figure 46 A<sub>2</sub>).

### 8.36.2 Test procedures

#### 8.36.2.1 Cords and chains with a single fixing point or with fixing points less than 94 mm apart

Apply a tension force of  $(25 \pm 2)$  N to the middle of the *cord* or *chain* and measure the perimeter of the loop.

In the diagram of A<sub>2</sub> Figure 43 A<sub>2</sub> the perimeter of the loop is equal to  $(a + b + c)$ .

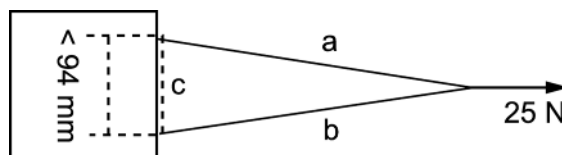

A<sub>2</sub>

Figure 43 A<sub>2</sub> — Measurement with fixing points less than 94 mm apart

#### 8.36.2.2 Cords and chains fixed to the toy at points of 94 mm or more apart

Place the test block with the attached strings under the *cord* or *chain* of the toy in such a way that it runs along the axis of the test block (see A<sub>2</sub> Figure 44 A<sub>2</sub>).

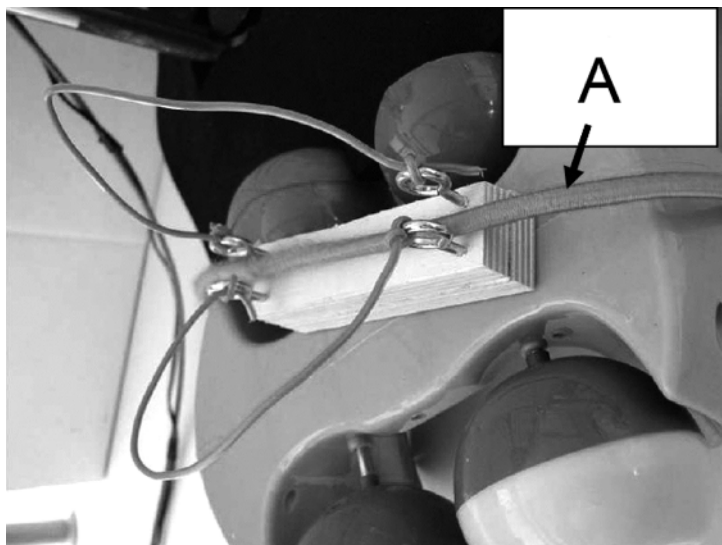

**Key**

A cord or chain of the toy

$\square_{A2}$

**Figure 44  $\square_{A2}$  — Position of the test block under the cord**

Using a force gauge or mass attached to the strings of the test block, apply a force of  $(25 \pm 2)$  N away from and perpendicular to the toy.

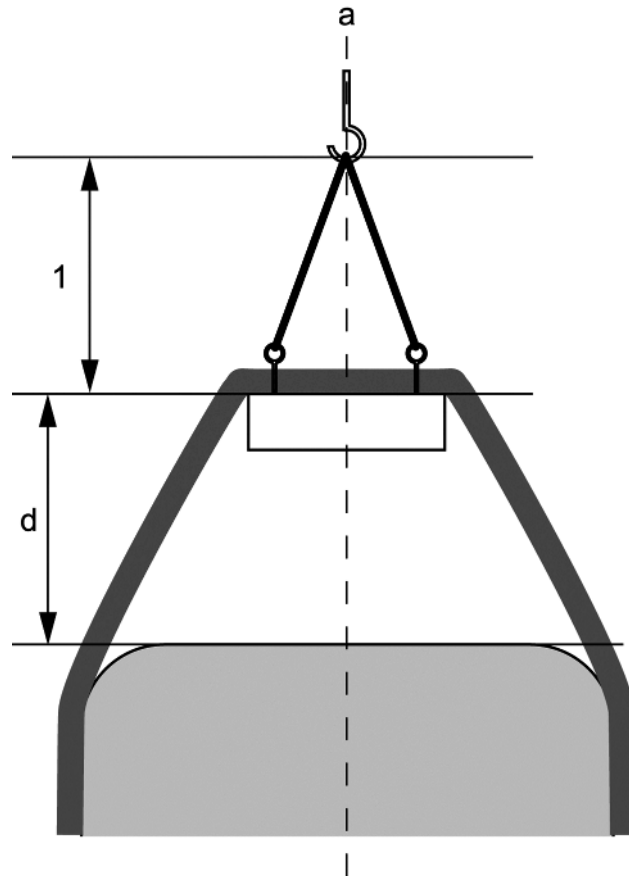

**Key**

1 approximately 0,1 m

$\square_{A2}$

**Figure 45  $\square_{A2}$  — Measurement of distance  $d$  in case of toys with flat surface**

Measure the distance  $d$  between the surface of the toy and the side of the test block in contact with the *cord* or *chain* (see  $\square_{A2}$  Figure 45  $\square_{A2}$ ).

In cases where the toy surface is not flat, position the second test block on the toy surface, parallel to the first test block and with its main axis in line with that of the first test block.

Measure the distance  $d$  between the side of the second test block in contact with the surface of the toy and the side of the test block in contact with the *cord* or *chain* (see  $\square_{A2}$  Figure 46  $\square_{A2}$ ).

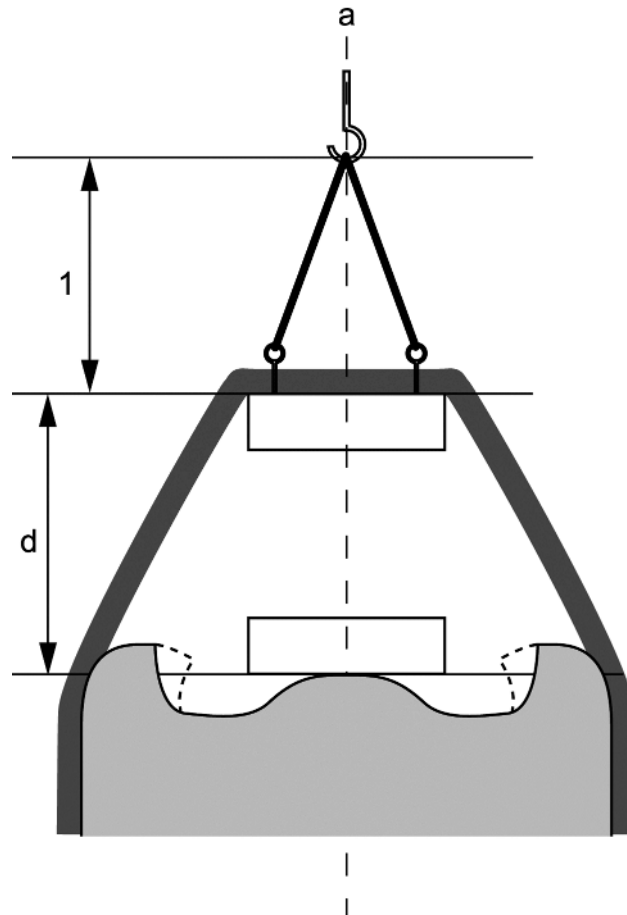

**Key**

1 approximately 0,1 m

$\square_{A2}$

**Figure 46  $\square_{A2}$  — Measurement of distance  $d$  in case of toys with an irregular surface**

### 8.37 Yo-yo balls measurements (see 4.24)

#### 8.37.1 Measurement of initial length $l_0$

Attach a fixed clamp to the maximum diameter of the *yo-yo ball* so that the tether can hang vertically beneath the clamp (see  $\square_{A2}$  Figure 47  $\square_{A2}$ ).



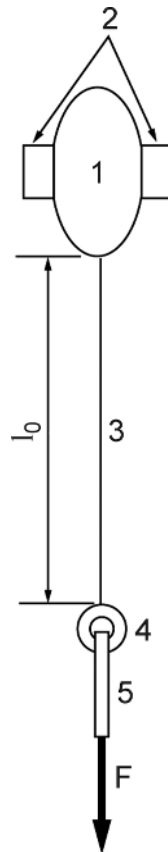

**Key**

- 1 ball
- 2 fixed clamp
- 3 tether made of *elastic material*
- 4 ring or other part made of *elastic material*
- 5 hook
- $l_0$  distance between the *ball* and the ring

**A<sub>2</sub>**

**Figure 47 **A<sub>2</sub>** — Measurement of the initial length  $l_0$  of yo-yo balls**

Apply a mass of  $(0,05 \pm 0,001)$  kg to the ring at the end of the tether made of *elastic material* or, if there is no ring, at a position 5 mm from the end of the elastic tether.

Measure the initial length  $l_0$  (see **A<sub>2</sub>** Figure 47 **A<sub>2</sub>**), in millimetres to an accuracy of  $\pm 1$  mm.

**8.37.2 Measurement of elastic constant k**

Attach a fixed clamping device to the *yo-yo ball* tether  $(15 \pm 5)$  mm from the *ball*. Position the tether vertically and attach a free clamping device to the tether at a distance of  $(15 \pm 5)$  mm from the ring at the end of the tether or, if there is no ring, at a distance of  $(15 \pm 5)$  mm from the end of the tether (see **A<sub>2</sub>** Figure 48 **A<sub>2</sub>**).

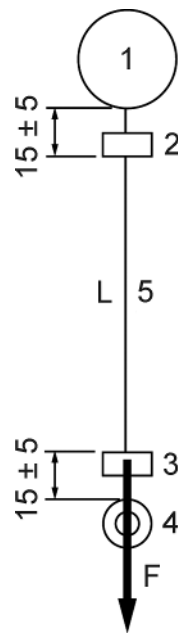

**Key**

- 1 ball
- 2 fixed clamp
- 3 free clamp
- 4 ring or other part made of *elastic material*
- 5 tether made of *elastic material*
- L distance between the two clamps



**Figure 48 — Clamp positioning to measure the constant k of yo-yo balls**

Apply a mass (including the mass of the free clamping device) of  $(0,1 \pm 0,005)$  kg to the free clamping device parallel to the axis of the tether made of *elastic material* and measure the distance  $L_1$  between the two clamps in millimetres to an accuracy of  $\pm 1$  mm.

Remove the force and allow the tether made of *elastic material* to relax to its approximate original length.

Apply a mass (including the mass of the free clamping device) of  $(0,2 \pm 0,005)$  kg to the free clamping device. Measure the distance  $L_2$  between the two clamps in millimetres to an accuracy of  $\pm 1$  mm.

Calculate k as in Equation 2:

$$k = \frac{1000}{L_2 - L_1} \quad (2)$$

**8.38 Breakaway feature separation test (see 5.4 b), 5.4 c) and 5.14)**

Fix one end of the *cord* or the *strap*. Apply a force of  $(25 \pm 2)$  N vertically to the other end, along the axis of the *cord* or *strap*, in such a way that the breakaway feature is in the middle between the fixing points. Observe whether or not the *cord*, *strap* or breakaway feature separates.

### 8.39 Self-retracting cords (see 5.4 e))

Position the toy such that the *cord* is suspended vertically beneath the toy and the force of the recoil mechanism is not impaired.

Attach a mass of  $(1 \pm 0,1)$  kg to the free end of the *cord*. Determine whether the recoil mechanism is able to lift the mass by retracting the *cord*, under any of the following conditions:

- with the *cord* extracted from the mechanism to the extent of 20 mm;
- with the *cord* extracted from the mechanism for a length equal to half of its maximum extractable length;
- with the *cord* extracted from the mechanism to its maximum extent.

### 8.40 Length of cords, chains and electrical cables (see 5.4 b), 5.4 c), 5.4 g), 5.4 h) and 5.4 i))

Fix one end of the *cord* or *chain* and apply a force of  $(25 \pm 2)$  N to the other end along the axis of the *cord* or *chain*. Measure, to an accuracy of  $\pm 1$  mm, the length of the *cord* or *chain* from the fixing point to the end of the *cord* or *chain*. If the fixing point has the same shape or form as the *cord* or *chain*, this part is measured as part of the entire *cord* or *chain* (see  $\text{A}_2$  Figure 49  $\text{A}_2$ ).

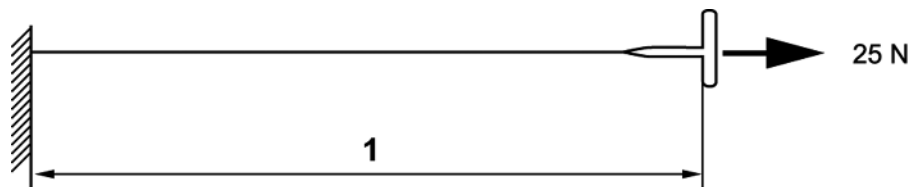

#### Key

1 length of *cord* or *chain*

$\text{A}_2$

Figure 49  $\text{A}_2$  — Measurement of the length of a cord or chain with attachments of the same shape or form as the cord or chain

NOTE For the purpose of this test method, an *electrical cable* is regarded as a *cord*.

## **Annex A**

(informative)

### **Background and rationale for this European Standard**

#### **A.1 General**

This European Standard seeks as far as possible to apply a hazard approach instead of design restrictions for toys. The following definitions should be kept in mind when reading the standard:

- hazard is a potential source of harm;
- risk is the probable rate of occurrence of a hazard causing harm and the degree of severity of the harm;
- harm is physical injury or any other damage to health, including long-term effects.

For most of the requirements, the hazard which is addressed is explained in Annex A together with a background and rationale.

#### **A.2 Scope (see Clause 1)**

In the scope, a number of toys are listed which this standard does not apply to. "Slings and catapults" includes slingshots but also, according to a communication from the EU Commission in 1992, toys (e.g. aeroplanes and rockets) which are propelled into free flight by a child releasing an elastic band.

In addition, a number of products are listed which, for the purpose of this standard, are not considered as toys. However, some comments are considered to be necessary:

- "toy vehicles equipped with combustion engines" also includes the engine itself as well as spare parts;
- "detailed and faithful scale models" covers, for example, replicas of ships;
- the exemption for "Fashion accessories for children which are not for use in play" does not apply to jewellery with play value, for instance jewellery sold with toy disguise costumes and (imitation) jewellery to be assembled by the child himself (for classification of toy creative kits, see European Commission's guidance document).

It should also be observed that the CE-marking is not to be affixed to products or toys excluded from this European Standard unless an EC-type examination certificate has been issued under directive 2009/48/EC, or if the product falls under the scope of another EU Directive which requires the affixing of the CE-marking.

#### **A.3 Material cleanliness (see 4.1)**

This requirement is intended to ensure that materials used in toys are new or, if reprocessed, so refined that the level of contamination of hazardous substances does not exceed that found in new material. There should be no infestation from animals or vermin.

According to Directive 2009/48/EC toys should be designed and manufactured in such a way as to meet hygiene and cleanliness requirements in order to avoid any risk of infection, sickness or contamination.

#### A.4 Assembly (see 4.2)

These requirements are intended to address hazards associated with toys which have to be assembled before they can provide play but have not been properly assembled (e.g. ride-on toys which, for practical reasons, are shipped in an unassembled state).

The requirements only apply to such assembly that is important from a safety point of view. The assembly of, for example, a model plastic kit is therefore not covered by this requirement.

For evident reasons, it is not possible to establish any safety criteria for something that a child builds using, for example, building blocks.

#### A.5 Flexible plastic sheeting (see 4.3)

These requirements are intended to address the hazards that might be associated with thin flexible plastic film, should it cover the face of a child or be inhaled and lead to *asphyxiation*.

Thin *plastic sheeting* may adhere to the child's mouth and nose making it impossible to breathe. If the thickness is greater than 0,038 mm, this risk is considered less significant.

With respect to balloons, see A.16.

#### A.6 Glass (see 4.5 and 5.7)

These requirements are intended to address the hazards associated with broken glass – for example sharp *edges*.

*Accessible* glass should as far as possible be avoided and should not be used unless necessary for the function of the toy.

Porcelain is used in, for example, toy tea sets and should still be allowed for children of 36 months and over. The hazard associated with broken porcelain is well known.

#### A.7 Expanding materials (see 4.6)

This requirement is intended to address the hazards associated with certain toys which expand substantially if swallowed. Such toys and parts of such toys are, if swallowed, considered to have the potential to lead to fatal accidents since they could cause obstruction of the intestines. If the toy has expanded more than 50 % in any direction after 24 h, 48 h or 72 h it has failed the test. An example of *expanding material* that is enclosed by a material intended to break during soaking is a “growing egg”.

#### A.8 Edges (see 4.7)

These requirements are intended to address the hazards associated with sharp *edges* on toys.

The standard refers to metal and glass *edges* only as there is no test method available for plastic *edges*. Manufacturers should however, in designing toys and in the production of tooling, avoid sharp plastic *edges* as far as possible.

It has been agreed that the test method for assessing sharp *edges* should be supplemented with a subjective assessment to determine the associated risk. There could be *edges* on toys that, although sharp according to the test method, are not a significant risk to the user of the toy.

The presence of *burr* on an *edge* is established by drawing a finger along the *edge*. To fail the requirement, the roughness needs to be sufficient to fail the sharp *edge* tester.

It has been established that it is not possible to manufacture electrical conductors (for example in battery boxes) which do not present sharp *edges*. This hazard has, however, been considered to be of a minor nature and allowance has therefore been given for such *edges*.

### **A.9 Points and metallic wires (see 4.8)**

These requirements are intended to address the hazards associated with sharp points capable of causing punctures of the skin, etc. It should, however, be noted that they do not intend to cover risks related to the eyes, which are too delicate to be protected.

It has been agreed that the test method for assessing sharp points should be supplemented with a subjective assessment to determine the associated risks. There could be points on toys that, although sharp according to the test method, are not a significant risk to the user of the toy, for example the points of pipe-cleaners, used as toys, that are so weak that they are not capable of puncturing the skin.

For children under 36 months, however, even points that are not sharp according to the test method may be hazardous. In 5.1 c) (toys intended for children under 36 months, general requirements), requirements are given for points with a cross-section of 2 mm or less.

Metallic wires and other metallic components that are designed and intended to be bent and metallic wires likely to be bent, whether covered by other materials or not, are tested according to a flexibility test to ensure that they do not break and produce sharp points.

Metallic wires and other metallic components designed and intended to be bent are subjected to 30 test cycles and metallic wires likely to be bent are subjected to one test cycle.

Metallic wires and other metallic components designed and intended to be bent are often used in *soft-filled toys*, which are considered suitable for children under 36 months. Should such a metallic wire break, it will eventually protrude through the covering and be hazardous. Metallic wires and other metallic components designed and intended to be bent are also often used in other types of toys for stiffening or retention of form.

Metallic wires likely to be bent accidentally can be found, for example, in the form of antennas on toys.

The requirements in 4.8 d) are not intended to cover for example U- or L-shaped cross-sections such as those often used in spokes in toy-umbrellas. Toys where the metallic wires cannot be bent in the manner that is described in the test method, without the metallic wires being removed from the toy, need not be tested.

### **A.10 Protruding parts (see 4.9)**

These requirements are intended to address the hazards associated with the users of toys falling on projections or rigid components on toys (e.g. *toy bicycle* handle bars, levers on go-carts, pram frames) possibly causing internal injury or skin puncture. Such protruding parts should be protected. The size and shape of the end protection has not been stipulated, except for *toy scooters*, but the end protection should be given a sufficiently large surface area to avoid puncturing of the body.

Since the requirement concerns hazards arising from a child falling on to a toy, it follows that this requirement relates only to vertical or nearly vertical projections. The toy is tested in its most onerous position.

If the projection is on a small toy which topples over when pressure is applied to the end of the projection, it is unlikely to be hazardous.

### A.11 Folding and sliding mechanisms (see 4.10.1)

These requirements are intended to address some but not all of the possible *crushing*, laceration and pinching harms that might occur due to the sudden and unexpected *collapse* of folding toys whether intended to support the mass of a child or not.

They are also intended to address the hazards associated with the child being trapped in a collapsing pushchair or perambulator, and with children getting their fingers jammed when playing with a toy.

Fatal accidents are known to have occurred when toy pushchairs have *collapsed* and the handle has come down over the head or throat of the child when the child has been trying to sit in or climb into the toy pushchair. It is, therefore, necessary to require that such pushchairs or perambulators should be equipped with two separate locking and/or safety devices as is the case for full-size pushchairs and prams.

Certain pushchairs are not designed with a handlebar that folds down over the toy when it *collapses* but folds together in a sideways direction. It has been agreed that such toys do not present the same severe hazard and consequently do not require two separate locking devices.

However, it has not been considered possible to eliminate all possible harms such as jamming when the toys are folded together in their intended way. Manufacturers should reduce the hazards as far as possible, for example by allowing for a 12 mm clearance between moving parts and by using safety stops. Great care should also be used when designing toys with folding or sliding parts so that scissor-like actions of moving parts are avoided as far as possible.

The requirements in 4.10.1 a), b), and c) cover toys that can *collapse*. Other toys with moving parts (e.g. excavating equipment on a ride-on tractor) are addressed by 4.10.1 d), and the requirement that these toys are intended for or capable of bearing the mass of a child excludes smaller toys.

### A.12 Driving mechanisms (see 4.10.2)

These requirements are intended to address the laceration and puncture hazards associated with sharp *edges* and points being exposed if the toy has been damaged. They are also intended to address pinching or laceration by entrapment of fingers in holes, in winder keys or between the winder key and the body of the toy.

*Driving mechanisms* should be enclosed in order to prevent jamming or *crushing* of fingers and other parts of the body. Toys that should be assembled by an adult are tested when assembled (see 4.2, assembly).



Small mechanisms are excluded, such as in small cars which would have insufficient power to jam fingers, and where power may be checked with a finger or a pencil inserted into the mechanism.

A mechanism would fail the requirement in this clause, were it to become *accessible* and the moving parts were liable to jam the fingers or otherwise injure a child.

### A.13 Hinges (see 4.10.3)

This requirement is intended to address the possible *crushing* hazard related to varying clearances along the *hinge line*, admitting fingers in one position of the hinged part but not in another.

It is only applicable to hinged assemblies in which both parts have a mass of 250 g or more and where the hinged moving part could be construed as a "door" or a "lid". For the purposes of this requirement, a door or lid can be defined as a closure of extended surface area with an extended *hinge line*. Other hinged parts without a significant surface area or *hinge line* would probably fall into the category of a folding mechanism (see 4.10.1, parts moving against each other, folding and sliding mechanisms).

The requirement relates to the entrapment of a finger and injury through squashing between *edges* along the *hinge line* and between surfaces parallel with the *hinge line* as shown in Figure 1 (see  3.32 , hinge line, definition) but not between other *edges* and surfaces of the assembly. There is only concern with the considerable forces which can be applied to the *edges* of the *hinge line* when the door or lid is closed or opened.

It has not been considered possible to specify a hinge area instead of *hinge line*. Manufacturers should, however, consider this and try to reduce the associated hazards, e.g. by allowing for a 12 mm clearance between moving parts near the *hinge line*.

#### **A.14 Springs (see 4.10.4)**

These requirements are intended to address the pinching or *crushing* hazards to fingers, toes and other parts of the body, associated with toys with *springs*.

#### **A.15 Mouth-actuated toys and other toys intended to be put in the mouth (see 4.11)**

These requirements are intended to address the *choking* hazard associated with unintentional inhalation of toys intended to be put in the mouth, mouth-actuated toys or detachable and *removable components* of these toys (e.g. their mouthpieces).

It is essential that such toys as well as *removable components* and components which become detached when tested according to relevant requirements are not so small that they can be unintentionally swallowed or inhaled. The requirement did previously only address removable or detachable mouthpieces of mouth-actuated toys but due to a new particular safety requirement in Directive 2009/48/EC the requirement had to be extended to address any removable or detachable component of such toys and of toys intended to be put in the mouth.

To ascertain that mouthpieces do not become loose if they become wet after prolonged use in the mouth, they are subjected to a soaking test before being subjected to the torque and tension tests. However, the soaking test is not applied to mouth-actuated *projectile* toys since they are normally not used in the mouth for a prolonged time.

To ascertain that small parts do not come loose when a mouth-actuated toy like a harmonica or whistle is used, these toys are subjected to a sucking and blowing test where a specified volume of air is forced through the toy.

This requirement applies regardless of the age of the child for whom the toy is intended.

#### **A.16 Balloons (see 4.3, 4.12 and 7.3)**

Balloons can be made of expandable latex or plastic. Plastic balloons made of metallized plastic are normally stronger than latex balloons and do not present the same risk of *choking* or *suffocation*. They therefore do not require the warning text in 7.3 (latex balloons).

Latex balloons are not covered by 4.3 (flexible plastic sheeting) as they are not made of plastic. Plastic balloons are normally so strong that they cannot be taken apart by a child and the thickness of the *plastic sheeting* should therefore be measured with double layers of sheeting (i.e. without tearing the balloon apart).

Products made from natural rubber latex can cause severe allergic reactions in some individuals. It is therefore important that balloons made from natural rubber latex are marked accordingly (see 7.3, latex balloons).



### **A.17 Cords of toy kites (see 4.13)**

These requirements are intended to address the electrocution hazard associated with toy kites that come in contact with overhead power lines. They also highlight the danger of flying a toy kite in a thunderstorm.

### **A.18 Toys which a child can enter (see 4.14.1)**

These requirements are intended to address the *asphyxiation* hazard associated with toys which might entrap and enclose the child completely (e.g. tents and toy chests).

All toys forming a confined space into which a child can enter are covered by this requirement regardless of whether the toy is designed to hold a child or not. Even if ventilation is ensured, it should be possible for the child to escape easily from the confinement without help from the outside.

4.14.1c) relating to toy chests was introduced to address the hazard associated with a child placing its head into the chest and the lid accidentally falling on to the child's neck, trapping the neck and causing *asphyxiation*. Such chests also have a play value.

### **A.19 Masks and helmets (see 4.14.2 and 7.8)**

These requirements are intended to address the *asphyxiation* hazard associated with insufficient ventilation of masks and helmets which enclose the head. Requirements are also necessary to address the hazards associated with visors on toy motorcycle helmets and similar articles which might break and damage the eyes.

It is essential that flexible masks do not adhere to the face of the child so that breathing becomes difficult.

The requirements also cover products that mimic protective equipment but are not intended to provide any protection to the child. Therefore items such as goggles which offer real protection to the child, are not classified as toys and are not covered by this standard.

Sunglasses intended for eye protection are not classified as toys but as personal protective equipment. However, sunglasses that have a play-value for children should also fulfil the requirements in EN 71-1 (e.g. sharp edges). Sunglasses for dolls, teddy-bears, etc. are classified as toys if they are too small for children to wear.

### **A.20 Toys intended to bear the mass of a child (see 4.15 and 7.10)**

These requirements are intended to address various hazards associated with inadequate strength and stability of the toy as well as insufficient braking capabilities of toy vehicles. The requirements are also intended to address the hazards associated with *chain* transmissions and wheel arrangements capable of *crushing* fingers and other parts of the body, if entrapped.

This European Standard contains requirements and test methods for bicycles with a *saddle height* of 435 mm or less. These small bicycles are not intended to - and should not - be used in the streets or on the highway. EN 14765 contains requirements and test methods for bicycles with a *maximum saddle height* that is less than 635 mm but more than 435 mm. Although it is not advisable, these bicycles are often used by young children in the streets near traffic. Legal requirements may exist in some countries relating to bicycles and their use by young children.

Requirements are given for roller skates, inline skates and skateboards intended for children with a body mass of 20 kg or less. Requirements for similar products intended for users over 20 kg can be found in standards for sports equipment: EN 13613 (skateboards), EN 13843 (inline-skates) and EN 13899 (roller skates). A warning regarding protective equipment is required for roller skates, inline skates and skateboards.

A warning regarding protective equipment is also required for electrically-driven ride-on toys unless they are intended for seated use and have passed the stability test, or have a maximum design speed not greater than 8,2 km/h, since in such cases protective equipment is not considered necessary.

The strength of the toy is tested by static and dynamic strength tests by applying a load to the toy. Two loads are specified, 50 kg for toys intended for children of 36 months and over, and 25 kg for toys intended for children under 36 months. In case of doubt as to which age range the toy is intended for, the greater load should be used. The dimensions of the loads are defined; however, when products such as pogo sticks are tested, the load will have to be distributed to the two foot pedals and it becomes impossible to define the design of the loads. For pogo sticks, the strength of the foot pedals is an important safety criterion since failure could result in injury.

The masses are based on anthropometric data and take into consideration the deterioration that toys are subject to during their lifetime.

The stability requirements do not apply to products which are not intended to be stable in their own right, e.g. pogo sticks.

Hand carts are wheeled toys in which one or more children may sit while being pulled along by another child or an adult.

If a toy which is designed to bear the weight of a child allows the child to use its feet to provide stability, the requirements do not apply. If the child is completely enclosed, the requirements should apply. It is a natural reaction for children to stabilise a toy with their feet when possible. However, the stability requirements apply to all toys intended for children under 36 months unless specifically excluded.

The braking requirements specify brakes for all ride-on toys with a *free-wheeling mechanism*. Toys with a *direct drive* are excluded from these requirements, e.g. certain tricycles with pedals on the front wheel, pedal cars and electrically-driven cars with a low maximum design speed (i.e. < 1 m/s) where the child's feet can be used for braking. Brakes are not required on ride-on toys without a *free-wheeling mechanism* partly because such vehicles are not intended to be used on sloping ground, and partly because no safe and easily operated braking systems are available. However, for ride-on toys that have no *free-wheeling mechanism* but are heavy, or are intended for simultaneous use by two or more children, a warning on the toy is required to inform the user and supervising adult that the toy is not equipped with brakes.

In assessing whether the motor on an electrically-driven ride-on toy has sufficient braking in itself, the toy should be subjected to one of the two available test methods. The complete equation for calculating the maximum pull-force is  $(M + 25) \times g \times \sin 10^\circ$ .  $\sin 10^\circ$  equals 0,173 and multiplied by 9,81 it equals 1,70.

Limits for the maximum design speed of electrically-driven toys are specified for toys intended for children of 6 years and over and for children under 6 years. Electrically-driven ride-on toys intended for standing use are permitted only for children over 6 years. Limiting the maximum design speed for toys intended for children under 6 years is intended to facilitate adult supervision whilst the toys are used. For toys intended for children of 3 years and over but under 6 years, a higher maximum design speed than 6 km/h is permitted, provided that the higher speed (8,2 km/h) can be achieved only if the setting of a special device has been changed by an adult supervisor with the use of a *tool*.

## **A.21 Rocking horses and similar toys (see 4.15.3)**

The requirements are intended to address the hazards associated with insufficient strength and stability of rocking horses and similar toys that might overturn unexpectedly. They also aim at warning supervising adults that children under 36 months should not be left unattended on rocking toys with a seat height over 600 mm, to avoid the risk of falls and injury.

## A.22 Projectiles (see 4.17)

These requirements are intended to address certain but not all potentially unexpected hazards associated with *projectile* firing toys and by the firing of improvised *projectiles* from such toys.

A toy in which the kinetic energy is determined by the toy and not by the child is typically a gun or other *spring*-loaded device. A pea-shooter is an example of a toy with a *projectile* (a pea) of which the kinetic energy is determined by the child by blowing.

Ground-based vehicular toys propelled along a track or other surface are not considered as *projectile* toys even if they include an element of motion in free-flight, e.g. between tracks.

The velocity of *projectiles* may be measured by direct or indirect means.

*Projectiles* with *suction cups* as an impact area have been involved in fatal accidents: therefore it is important that the *suction cups* are either large or firmly attached and that the length of these *projectiles* is sufficient to aid removal if a *suction cup* is blocking the airway. The requirement for a length of 57 mm or more applies also after testing to 8.3 (torque test) and 8.4.2.1 (tension test, general), meaning that, if the shaft breaks during testing, the part to which the *suction cup* is attached has to be at least 57 mm long after testing.

## A.23 Aquatic toys and inflatable toys (see 4.18 and 7.4)

These requirements are intended to address the hazards associated with the sudden loss of buoyancy of inflatable *aquatic toys* if air is released through the inlet with drowning as a possible consequence. They also aim at informing adults and children of the dangers of using these toys in deep water. Furthermore, they intend to address the *asphyxiation* hazard associated with unintentional inhalation of stoppers on air inflation inlets. The standard covers inflatable toys intended to bear the mass of a child and used for play in shallow water and generally under the supervision of an adult as well as other inflatable toys provided with air-inflation inlets with stoppers.

Stoppers on air-inflation inlets on all types of inflatable toys should not become detached. Stoppers on *aquatic toys* should be protected against being inadvertently removed. Non-return valves are often provided to facilitate the inflation of the toy.

Inflatable boats and mattresses which are larger than 1,2 m are not classified as toys but as floating leisure articles which are covered by the General Product Safety Directive. Aquatic ride-on toys such as inflatable dolphins and crocodiles are considered toys regardless of their size, but special safety requirements apply to such toys if they are larger than 1,2 meters since they are then considered to be sensitive to wind drift and thus present a risk of drifting away to deep water. Such toys need to fulfil the applicable requirements in both EN 71-1 and EN 15649-3 (including requirements in other parts of EN 15649 to which EN 15649-3 refers).

In addition, armbands are classified as personal protective equipment and flotation aids are classified as swimming aids rather than as toys.

## A.24 Percussion caps specifically designed for use in toys and toys using percussion caps (see 4.19)

These requirements are intended to address the thermal hazards associated with sparks, flame and glowing parts, capable of causing eye injuries, produced by toy percussion caps accidentally exploding outside the toy weapon, or by excessively dangerous explosive behaviour of properly used caps due to inadequate construction or manufacturing. The requirements also address the hazards associated with the simultaneous discharge of a large number of caps.



## A.25 Acoustics (see 4.20)

These requirements are intended to address the auditory hazards associated with high continuous and impulse sound pressure levels. They apply only to toys that are clearly designed to emit sound, i.e. toys that have sound-producing features such as electric or electronic devices, percussion caps, rattling components etc. Unintentional sound from the operation of the toy is excluded from the requirements. Examples of unintentional sound are sounds from: a marble track, pulling back a pull-back car, opening or closing a lid or door, the spring wind-up mechanic clicking or the light “zooming” noise of the motor of a radio-controlled car, etc.

It should be observed that it is not necessarily optimal to design a toy to emit sound close to the limit values since the most comfortable sound level at the ear for human listeners is in the range from 50 to 70 dB(A). For toys intended to be used in a noisy environment, it may, however, be necessary to increase the sound level. When the sound level increases the auditory performance of the ear decreases due to a reduced ability to discern fine details in the acoustic signal. Furthermore, sound levels below the range 75-80 dB(A) at the ear constitute no risk for permanent damage of the human ear, essentially independent of exposure time.

As yet there exists no scientific evidence that the sensitivity of children to loud sound is significantly different from that of adults. The limit values of the standard are based on the lower action values found in Directive 2003/10/EC [18] (commonly referred to as the “noise at work directive”), that is  $L_{EX,8h} = 80$  dB(A) for prolonged exposure and  $L_{pCpeak} = 135$  dB for acute exposure. It should be noted that these values represent the highest levels of protection since under Directive 2003/10/EC, workplaces found to have this level of noise are only obliged to make hearing protection available to those that request it, in order to protect the most sensitive individuals. These limit values are related to the position(s) normally occupied by the head of the person which is affected by the noise. For the purpose of this European Standard the appropriate reference point has been estimated at a distance of 2,5 cm from the ear of the child for *close-to-the-ear toys* and C-weighted peak sound pressure levels in general and at a distance of 25 cm for *time-averaged emission sound pressure levels* for toys other than *close-to-the-ear toys*. 2,5 cm was chosen as studies [20] have shown this to be the closest distance at which children hold the toys. The value of 25 cm was selected as an exposure distance for other toys as observations [20] have shown that this represents a typical distance at which such toys are used.

A decisive factor for continuous noise is the daily exposure time, as each doubling of the duration corresponds to an increase of 3 dB in *emission sound pressure level*. Studies have shown that children play with manufactured toys (sound-producing or not) and computer games for a maximum of between 2 and 5 h a day. For the purposes of this standard the duration of 2 h per day has been assumed for play with sound-producing toys. As a further refinement of the exposure time it has been noted that it would be extremely unlikely that some toys could make sound for the entire playing time since some toys need to be reactivated at short time intervals. To take this effect into account toys have been divided into three exposure categories corresponding to an effective daily operating time of 120 min (the full two hours), less than 40 min (one third of the full two hours) and less than 12 min (one tenth of the full two hours). When using the reference time of 2 h (120 min) the two other effective operating times correspond to a correction of - 5 dB and -10 dB respectively. It has been assumed that toys that need initiation more often than every 5 s to emit sound or that otherwise require a significant effort to make sound will not be in operation during more than 1/10 of the total playing time. If the sound emission lasts for more than 30 s after each initiation it has been assumed that the toy will be in operation during more than 1/3 of the playing time. For peak sound pressure levels the exposure time is not relevant since one single occurrence of a sound with a high instantaneous sound pressure can cause immediate hearing damage. Considering this risk, limit values for peak levels assume a worst case position of the toy close to the ear except in the case of *percussion toys* such as drums and xylophones which have been considered not possible to use close to the ear.

These assumptions yield a limit value for the A-weighted *time-averaged emission sound pressure level* of 86 dB, or, when rounded, 85 dB measured at the ear and a C-weighted *peak emission sound pressure level* limit of 135 dB (since this is not time dependant). The distance law (6 dB attenuation for each doubling of the distance) has been used to calculate the effective limit values at the specified measurement distance.

Applying the distance law between the close-to-the-ear location at 2,5 cm and the measurement distance at 50 cm corresponds to a sound level difference of 26 dB. Thus the peak limit value 110 dB at 50 cm corresponds to 136 dB, or, when rounded, 135 dB at 2,5 cm. In practice, a measured level of 110 dB at 50 cm will often yield peak levels lower than 135 dB when experienced from 2,5 cm, in particular when dealing with an extended source (a source which is not a point source), thus this use of the distance law represents a worst case. The calculated limit values have been rounded downwards as a further precaution. In line with other European Standards A-weighting has been used for time-averaged sound pressure levels and C-weighting for peak sound pressure levels.

*Close-to-the-ear toys* have an estimated normal use distance of 2,5 cm from the ear. The test method requires the microphone to be placed at a distance of 50 cm away from the toy. Using the distance law (increasing the distance from 2,5 cm to 50 cm results in a 26 dB attenuation), the limit value for *close-to-the-ear toys* has been set to 85 dB (86 dB before rounding) at 2,5 cm yielding 60 dB when measured at 50 cm. A child will not always use toys in the intended way. For example, a child can use some toys as *close-to-the-ear toys* (e.g. toys shaped like a telephone) also if this is not the intended use. This may lead to a risk of over-exposure to sound pressure. Toys that can be considered easy to confuse with *close-to-the-ear toys* should therefore be tested as *close-to-the-ear toys*. Incidental exposure by holding toys next to the ear, occasionally and briefly, is however addressed by the *peak emission sound pressure level* limits. The different exposure categories should be considered for *close-to-the-ear toys* (and toys that can be easily confused with these). The consideration shall regard not only the time during which sound is emitted but also the time during which the toy is actually held close to the ear, since these actions need to coincide for the close-to-the-ear exposure to be present. For peak sound the worst case distance has been set to 2,5 cm and using the distance law the limit value has been calculated to 110 dB (135 dB – 26 dB rounded) when measured at 50 cm.

Toys using headphones or earphones are expected to fall into exposure category 1, as they are always expected to be effectively used during more than 1/3 of the total playing time. These toys have been assigned a *time-averaged emission sound pressure level* limit of 85 dB and a *peak emission sound pressure level* limit of 135 dB. These values correspond exactly to the limits taken from Directive 2003/10/EC [18] since the measurement of the *emission sound pressure levels* takes place in an ear simulator. The measurement results from the simulator need, however, to be converted into a free-field equivalent since the limit values were specified under these conditions. Conversion of the A-weighted *time-averaged emission sound pressure level* is carried out in accordance with the ear simulator manufacturer's data on free field correction or, if no data is available, the conversion can be carried out in accordance with IEC/TS 60318-7 with a 0° response. The *peak emission sound pressure level* is more difficult to convert since this is an instantaneous measure. The *peak emission sound pressure level* measure is effectively a measure of an impulse within a continuous sound. Impulse sounds usually contain the most energy within the higher frequency bands which is also the region where the simulators will differ most from a free-field measure. It has been estimated that the difference between the ear simulator and the free field could be at least 10 dB for these higher frequency, impulse sounds. The free field limit values given are approximately equal to the limits given for *close-to-the-ear toys*.

Unless otherwise stated the toys mentioned below have been assigned a normal use distance of 25 cm and a worst case use distance of 2,5 cm. At a measurement distance 50 cm, these normal use distances correspond to the limit values 80 dB (for the A-weighted *time-averaged emission sound pressure level*) and 110 dB (for the C-weighted *peak emission sound pressure level*) respectively.

*Hand-held toys and table-top or floor toys.* Considering way of operation and use each toy has to be assigned the most appropriate exposure category. As to the size of the measurement box an assumption has been made that toys to be tested in a free field are never larger than 1 m and that toys on the floor may be larger and thus may require additional microphone positions.

*Rattles.* As *rattles* are unlikely to make sound effectively more than 1/3 of the time of use they have been put in exposure category 2 increasing the 80 dB limit to 85 dB. As, for the reason of better reproducibility, the test method for the A-weighted *time-averaged emission sound pressure level* requires that adult testers shake the toy under test violently and with highest possible frequency, the test method will yield an overestimate of the time-averaged sound pressure level. As collected test data have shown that this overestimate relative normal use is typically around 5 dB, 5 dB is to be subtracted from the measured value before it is compared with the limit value 85 dB. The measurement of the C-weighted *peak emission sound pressure level* aims at producing

the highest sound level when shaking at a slow pace and refers to a worst case situation. Since this is a worst case situation, no such subtraction is made from the measured value before comparing with the limit value. Toys that are used in the same manner as *rattles* (e.g. toy maracas) should be tested using the method specified for *rattles*.

*Squeeze toys.* As *squeeze toys* are unlikely to make sound effectively more than 1/3 of the time of use they have been put in exposure category 2 increasing the 80 dB limit to 85 dB. As, for the reason of better reproducibility, the test method requires that adult testers use maximum force with highest possible frequency, the test method will yield an overestimate of the time-averaged sound pressure level. As collected test data have shown that this overestimate relative normal use is typically around 5 dB, 5 dB is to be subtracted from the measured value before it is compared with the limit value 85 dB. As peak measurements refer to a worst case situation no such subtraction is to take place for the measured peak sound pressure levels.

*Pull-along or push toys* clearly designed to emit sound. The test method for these toys is a pass-by test, as they have to be in movement in order to generate sound. Because of the movement the distance to the stationary microphone will vary and, accordingly, the sound pressure level will vary, with the position of the toy. For that reason the A-weighted *maximum sound pressure level* using time-weighting F is to be measured instead of the time-averaged sound pressure level. Time-weighting F has been chosen in order not to risk underestimating the *maximum emission sound pressure level* from a source passing by at a short distance. However, the limit value will be the same as the corresponding time-averaged value for stationary sources as it has been assumed that the playing child will move with the toy at a constant distance yielding the *maximum emission sound pressure level*. Thus the limit values become 80 and 110 dB for the A-weighted *maximum emission sound pressure level* and the peak C-weighted sound pressure level respectively.

*Percussion toys.* Since the worst case use scenario for these toys is where the user strikes the toy very hard with the beater (or a hand), the worst case use distance has been set to 25 cm also for *peak emission sound pressure levels* since it is improbable the toy could be held any closer to the ear while using such force. This gives a limit value of 130 dB for the *peak emission sound pressure level*. As *percussion toys* are unlikely to make sound effectively more than 1/3 of the time of use they have been put in exposure category 2 increasing the 80 dB limit to 85 dB. As, for the reason of better reproducibility, the test method requires that adult testers use maximum force with highest possible frequency, the test method will yield an overestimate of the time-averaged sound pressure level. As collected test data have shown that this overestimate relative normal use can be up to 10 dB for *percussion toys*, 10 dB is to be subtracted from the measured value before it is compared with the limit value 85 dB. As peak measurements refer to a worst case situation no such subtraction is to take place for the measured peak sound pressure levels.

*Wind toys.* As *wind toys* are unlikely to make sound effectively more than 1/3 of the time of use they will either be put in exposure category 2, e.g. some toy instruments, increasing the 80 dB limit to 85 dB, or in exposure category 3, e.g. whistles, increasing the limit value to 90 dB. As, for the reason of better reproducibility, the test method requires that adult testers use maximum blow force, something that has been shown to be very difficult for periods longer than a few minutes, the test method will yield an overestimate of the time-averaged sound pressure level. As collected test data have shown that this overestimate relative normal use is typically around 5 dB, 5 dB is to be subtracted from the measured value before it is compared with the limit value 85 dB. As peak measurements refer to a worst case situation no such subtraction is to take place for the measured peak sound pressure levels.

*Cap-firing toys.* As *cap-firing toys* are unlikely to make sound effectively more than 1/10 of the time of use they have been put in exposure category 3 increasing the 80 dB limit to 90 dB. As to peak sound pressure levels the 110 dB limit is based on requirements for sounds in general. However, research has shown, Price et al.[19], that very short impulses with pulse lengths shorter than 0,2 ms, will not cause hearing damages at levels up to at least 151 dB at the ear, which corresponds to 125 dB at the measurement distance 50 cm. Thus the *peak emission sound pressure level* limit has been set to 125 dB since percussion caps have a sound duration of approximately 0,15 ms.

*Voice toys.* Each toy needs to be mounted in the most appropriate way considering its mode of operation. Each toy has to be assigned the most appropriate exposure category. 

## A.26 General requirements for toys intended for children under 36 months (see 5.1)

These requirements are intended to address the hazard associated with insufficient strength and durability of young children's toys, which are generally subject to considerable wear and tear. They are intended to address the hazards associated with small parts, capable of causing *choking*, being inhaled or swallowed, as well as hazards in connection with sharp *edges*, sharp points and *springs*, which jam fingers, etc.

Young children have a well-known habit of putting things into their mouths, and toys and toy components for this age category should, therefore, have a minimum size to avoid *choking*. They should also have sufficient strength to resist considerable wear and tear.

Certain materials, e.g. fabric and yarn, are as a general rule excluded from the requirements in 5.1. However, a tightly packed stuffed component made of these materials cannot be generally excluded from the requirements since it can present the same hazard as a small hard part made of non-excluded materials. A stuffed component should be considered as tightly packed only if it cannot be readily compressed by hand (between forefinger and thumb). Such a component should, however, not be considered hazardous if it does not remain tightly packed also after having been subjected to the relevant tests. This can be the case, for example, when the fabric of a tightly packed stuffed component splays out to reveal the stuffing material when the component becomes detached.

<sup>A3</sup> In 2014, it was clarified that the exemption for "fabric" covers "felt" and "elastic fabric". Thus, elastic polymeric materials that are interwoven in an elasticized fabric, as well as elasticized thread sewn in to a fabric, are excluded from the general requirements of 5.1. Elastic polymeric materials (e.g. rubber bands) that are not interwoven in, or sewn in to, a piece of fabric material are not excluded from the general requirements of 5.1.

*Paper* is also excluded from the requirements in 5.1, as *paper* components do not have the mechanical strength to pose any significant *choking* hazard.

Practical experience indicates that pieces of *paperboard* cannot easily be torn off or chewed off from *paperboard* components until the material becomes wet, thus losing mechanical strength. The released, wet pieces pose no significant *choking* hazard. Therefore, *paperboard* toys and *removable components* made entirely of *paperboard* are excluded from the foreseeable use testing requirements in 5.1 b). Accident data would support this, showing a distinct lack of serious *choking* incidents related to *paperboard*.

The requirements in 5.1 a) however stipulate that *paperboard* toys, *removable components* of *paperboard*, and weakly attached *paperboard* components must not be small parts. Dry *paperboard* pieces that are small parts in their as received state, and *removable components* that are small parts, may pose a risk of *choking* since they could be ingested or inhaled without previous wetting. For the same reason, small part *paperboard* components that are weakly attached are considered to present the same hazard. The application of the tension test in 5.1 a) for attached *paperboard* components is a reflection of this assessment of the particular hazard posed by dry *paperboard* components. The tension test in 5.1 a) was added as a precaution to minimize hazards associated with children removing small part *paperboard* components that are weakly attached.

It should be noted that some *paper* and *paperboard* components have polymeric lamination, thick coatings like varnish, or other treatments which may mean they are more resistant to wetting with an increased potential *choking* hazard as a result. If *paper* or *paperboard* components (with or without such treatments) present the same properties as *paper* or *paperboard* (e.g. that *paper* can be easily torn), they should be exempted from the requirements of 5.1 b).

The test programme for toys intended for children under 36 months is similar to the use and abuse tests specified in ASTM F 963 [2]. <sup>A3</sup>

Regarding the requirements for metal points and wires in 5.1 c), see comments in A.9.

The intention of the requirement for casing of toys in 5.1 g) is to ascertain the strength and durability of e.g. the casing of chiming toys and *rattles* which may include hazardous small parts, *edges* and points. If such casings *crack*, they will eventually fall apart and present hazards to the child.

The purpose of the soaking test in 5.1 e) for toys that are glued together is mainly to check the strength of the joint. Other properties of the toy which might be affected by the soaking are not considered except thick surface coatings such as varnish which may come loose.

Plastic stickers and decals (see 5.1 e)), self adhesive or not, glued on the toy and which come loose during the soaking test should pass the test for *plastic sheeting* as required in 4.3 (flexible plastic sheeting) and the small parts test (8.2).

Wood knots in wooden toys are by nature never the same, and no conclusion about the safety level for a certain kind of products can be drawn from a single toy with loose wood knots. Small wood knots in wooden toys which can easily be pulled or pushed out are, however, to be considered as *removable* small components.

### **A.27 Soft-filled toys and soft-filled parts of a toy (see 5.2)**

The requirements in 5.2 a) and 5.2 b) are intended to address the hazards related to objects that can cause cuts or lacerations if *accessible*, or *choking* if inhaled, or harm by ingestion.

The requirement in 5.2 b) is therefore intended to ensure that a child cannot get access to small parts should a seam break open on a *soft-filled toy* or a *soft-filled* part of a toy containing small parts or a containing a *filling* that could potentially release a small part.

Note that *soft-filled toys* and toys with coverings from which pieces can be bitten or torn off (e.g. foam toys) should meet the requirements in 8.3 (torque test) and 8.4 (tension test) as required in 5.1 (toys intended for children under 36 months, general requirements).

The requirement in 5.2 c) covers *soft-filled toys* and *soft-filled* parts of a toy, containing fibrous *filling* materials and no small parts.

Despite uncertainty as to the hazard presented by fibrous *filling*, it has been deemed prudent to require that the seams of *soft-filled toys* undergo a tension test. The requirements in 5.2 c) are therefore intended to ensure that the seams of such *soft-filled toys* do not come apart in a way that enables a child to insert two fingers through a seam to pull out clumps of *filling* (simulated by a 12 mm probe inserted to a depth of more than 6 mm).

### **A.28 Adhesion of plastic sheeting (see 5.3)**

These requirements are intended to address the hazards associated with *plastic sheeting* or plastic decals on toys – for example when children pull them off and put them over the face, forming an airtight seal capable of causing *suffocation*, or into the mouth.

### **A.29 Cords and chains in toys (see 5.4)**

These requirements are intended to prevent children from being strangled by *cords* or *chains* on toys. They also address the risk of the child being entangled by a self-retracting *cord* on e.g. a chiming toy.

*Electrical cables* intended to be connected to a computer or a TV are excluded from the definition of *cords* [and hence the requirements for *cords*] because restricting the cable length might not allow the toy to function correctly. Moreover, TVs and computers not having a play value on their own are not toys and any *electrical*



*cables* used to connect them to the toy that are not permanently attached to the toy or supplied with the toy, should be considered as accessories of the TV/computer.

The requirement in 5.4 a) is intended to address the hazard of a *cord* slipping through the hands causing skin abrasion. This hazard is mainly present in pull-along toys and in toys with self-retracting *cord* mechanisms, due to their specific play function.

The requirement in 5.4 b) is intended to ensure that *cords* cannot be wound around the neck and lead to strangulation. This hazard is present when the *cord* has attachments, knots or *fixed loops* that could cause the *cord* to tangle around the neck without the child being able to remove the *cord*.

References regarding age grading of toys e.g. "intended for children under 18 months" can be found in the CPSC Age Determination Guidelines and in CR 14379 (see Bibliography).

The requirements in 5.4 c) and 5.4 d) are intended to ensure that a *fixed loop* or a *noose* cannot be pulled over a child's head causing a strangulation hazard.

Note that plastic tips on shoelaces are not considered as attachments likely to form a *noose*.

Two test methods are described in 8.36.2. The elasticity of some *cords* prevents the use of test probes: these were considered but are thought to produce inconsistent results between testers.

The aim of the tests is to assess whether or not the head of a child can fit through a *fixed loop*. CEN/TR 13387:2004 has been used as the source for the appropriate head dimension for children of less than 3 months (see Figure A.1).

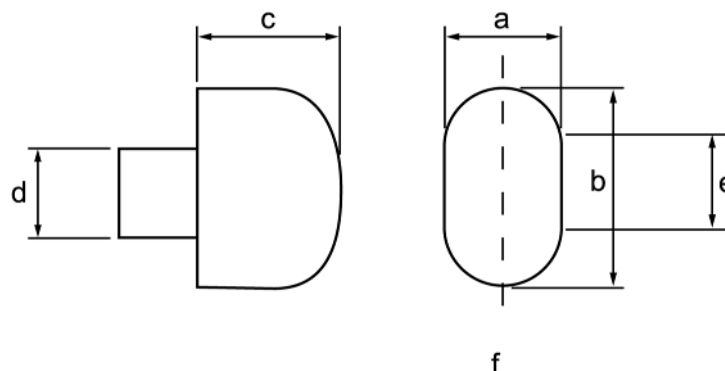

**Key**

- a 96 mm
- b 124 mm
- c 112 mm
- d 42 mm
- e 28 mm
- f probe main axis

**Figure A.1 — Head probe (representing children of less than 3 months)**

This probe is 96 mm in width, has two hemispherical ends with a radius of 48 mm and, as a consequence, a short flat side *e* which is 28 mm in length. The total perimeter of the probe is therefore 357 mm.

Since the limit of 380 mm, specified in EN 71-1 as the maximum perimeter of a *noose*, has been effective in preventing strangulation, the probe dimensions in Figure A.1 were changed to achieve the necessary values

for the development of the test method for the perimeter of *CORDS* and *CHAINS*. A probe with the following dimensions was chosen to achieve a perimeter of approximately 380 mm:

*a*: 96 mm;

*b*: 136 mm;

*e*: 40 mm.

When the *CORD* attachment points are close to one another, it is easy to insert this probe with its main axis (see Figure A.1) perpendicular to the toy. If the perimeter of the *CORD* is greater than 380 mm the probe can be inserted.

If the *CORD* attachment points are further apart it is easier to insert the probe with its main axis parallel to the toy. In this case, to insert the probe, it is necessary for the distance between the toy and the *CORD* to be at least 96 mm.

The dimensions at which the insertion of the probe becomes possible with the probe main axis parallel to the toy are as follows:

- 1) perimeter of the probe: 380 mm;
- 2) width of the probe: 96 mm.

Therefore, if a rectangle with a perimeter of 380 mm and two sides of 96 mm is used, the other two sides should be 94 mm long.

The test has been designed to give the same result when the perimeter of a *CORD*, which is attached to the toy at two points which are 94 mm apart, is assessed using either the test method in 8.36.2.1 or the method in 8.36.2.2 (see Figure A.2).

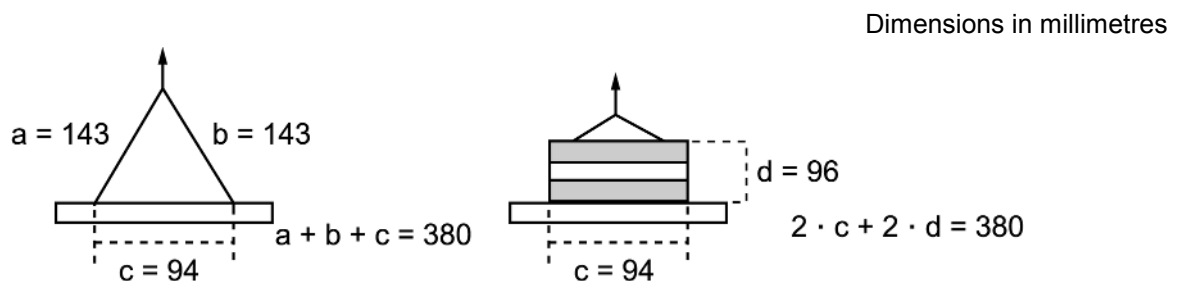

**Figure A.2 — Example of the same cord on the same toy measured with the 2 different test procedures**

The requirement in 5.4 f) is intended to address the strangulation hazard that could be presented by toys that are intended to be attached to child-care articles such as cradles, cots and perambulators. Such toys should be removed when the child starts trying to get up on its hands and knees in a crawling position. A toy intended to be strung across a cradle, cot or perambulator, could otherwise present a strangulation hazard, should the child fall with its neck across the strung toy, unable to get up. A toy which is intended to be attached to such child-care articles by other means, and that has *CORDS* (e.g. a “mobile”) intended to be placed out of the reach of the child, could also present a strangulation hazard if the child can reach the *CORDS* and become entangled.

The requirement in 5.4 g) is intended to ensure that *CORDS* attached to toys are not long enough to allow children under 18 months to wrap around them with the consequent risk of strangulation.

The requirement in 5.4 h) for *CORDS* used on pull-along toys intended for children under 36 months was introduced in 2010 at the request of the European Commission. It is recommended that manufacturers limit

the length of such *CORDS* to the minimum length necessary for the proper function of the toy and always to less than 800 mm. The length of 800 mm is based on the presumption that the distance from the hand to the ground of a three-year-old child is approximately 400 mm and that the angle of the *CORD* to the ground during use is approximately 30°.

### A.30 Liquid-filled toys (see 5.5 and A.42)

These requirements are intended to address the hazards associated with punctured *teethers* and similar products where the child might come into contact with liquids that are contaminated or become contaminated due to a puncture.

The requirements do not apply to electrolyte in batteries nor to paints, finger paints or similar items in containers.

The warning required in 7.12 is intended to make parents aware of the hazard associated with a *teether* which is so cold that it could harm the child.

### A.31 Shape and size of certain toys (see 5.8 and A.43)

These requirements are intended to address hazards associated with toys intended for children who are too young to sit up unaided, and that could cause impaction.

Toys should be tested according to 8.16 (geometric shape of certain toys) "as supplied". In other words, they should be tested for this requirement before other relevant tests are conducted. However, parts that become *accessible* after opening e.g. a velcro-closure should be tested after having been removed from the closure.

In determining which toys are intended for such children, the following factors are relevant: the manufacturer's stated intent (such as on a label) if it is reasonable, the advertising, the promotion, the marketing and whether the toys are generally considered as suitable for the age group in question.

It is recognised that children normally sit up unaided between five and ten months.

### A.32 Toys comprising monofilament fibres (see 5.9)

Monofilament fibres attached to fabric base is not the usual method of production, but a toy made in this way was involved in the death of a child of 5 months. The requirement does not apply to monofilament hair which is normally rooted in a dolls head or to pile fabric used in the manufacture of teddy bears and animals etc., for which there are no accident data.

### A.33 Warnings, markings and instructions for use (see 7.1)

**[A1]** In the following good practice, the guidance documents ISO/IEC Guide 37, Instructions for use of products of consumer interest and CEN/CENELEC Guide 11, Product information relevant to consumers – Guidelines for standard developers have been considered and adopted where appropriate.

#### Good practice for visibility and legibility:

a) Emphasising the warning:

- 1) emphasise warnings e.g. by placing them in a prominent position on the toy and/or its *packaging*. The prominent position does not necessarily mean the front panel of the *packaging*. Note that the age warning symbol alone (without the word "Warning") can be placed e.g. on the front of the

*packaging*, provided that a complete warning (including the word "Warning") is present on another location of the *packaging*;

- 2) avoid large amounts of information;
  - 3) do not mix safety information with commercial information;
  - 4) the text of the warnings on the *packaging* should be conspicuous and reasonably related to the font, visibility, legibility and size of other printed matter on the *packaging*;
  - 5) in multi-language text, clearly separate the individual languages, for example by a flag, spacing, country code or other means.
- b) Contrast, background and colours:
- 1) the colour of the warning should be in sharp contrast with the colour of the background. Avoid using similar foreground and background colours such as white text on yellow background. Dark ink on bright paper or bright ink on dark paper provides good contrast;
  - 2) when using the age warning symbol, ensure contrast between the red circle and the background on which the pictogram is placed;
  - 3) for the background of the warning avoid strong background patterns or images that may interfere with the warning;
  - 4) avoid red-green and blue-yellow colour combinations, as these may create problems for persons with colour-vision deficiency.
- c) Reflecting surfaces and obscuring material:
- 1) avoid highly reflecting surfaces and highly reflecting glossy paper leading to poor legibility for surfaces displaying warning text. Avoid transparent *packaging* material that may obscure, blur or deform the warning text.
- d) Font type:
- 1) preferably use sans-serif font types. Avoid the use of different font types in the warning text.
- e) Font size:
- 1) no recommendations for a minimum font size have been set. Setting minimum recommendations might encourage the use of only the smallest specified font size. It is considered more appropriate to give recommendations on other factors that are important for the visibility and legibility of a warning text. However, it is strongly recommended that the font size is increased where possible to improve the visibility and legibility of text. Use font sizes that allow all target groups, including those with corrected vision, to read the warning and
  - 2) consider using larger warning symbols than the minimum size as specified in 7.1 and 7.2.
- f) Logical direction of text:
- 1) place the warning in the logical direction considering the lay-out of the information on the surrounding *packaging* or, if appropriate, the normal orientation of the toy. 

#### **A.34 Warning for toys not intended for children under 36 months (see 7.2)**

The use of the warning should not be misleading or incorrect. Toys intended for children under 36 months should comply with the requirements of Clause 5 (small parts, small *balls*, sharp *edges*, sharp points etc.). The warning does not release the manufacturer or his authorized representative from his obligation to meet these requirements. Information on deciding which toys are intended for children under 36 months and which toys are not, for example, can be found in CR 14379.

The use of the warning should not be confused with a recommendation for use. A recommendation for use could, for example, be a positive age recommendation by the manufacturer indicating the intended age of use.

Unnecessary warnings should be avoided as they reduce the effectiveness of such statements.

#### **A.35 Warnings in connection with functional toys (see 7.5)**

The manufacturer has to specify a suitable minimum age, below which the toy should be kept out reach of the child.

#### **A.36 Small parts cylinder (see 8.2)**

This cylinder has been taken from the American Code of Federal Regulations, CFR Title 16, Part 1000 to end, §1501 Figure 1. For the purpose of this European Standard, tolerances have been added to the dimensions.

It is important to determine whether the toy fits entirely within the cylinder. This can be assessed by placing a sheet of clear plastic over the top of the cylinder to ensure that no parts of the toy protrude above the top of the cylinder. It is also important to ensure that the toy is not compressed in any way.

#### **A.37 Tension test (see 8.4)**

When dealing with soft materials, clamps used to attach the mass or force to the component can cause damage to the component or to the material to which the component is fixed, and in this way compromise the test. If damage occurs, any further test(s) should be performed on a new toy.

#### **A.38 Impact test (see 8.7)**

The most onerous position can, in many instances, be the plastic seams of *rattles* and similar toys.

#### **A.39 Compression test (see 8.8)**

This test is restricted to those parts of relevant toys that in the drop test would not come into contact with the shore A hardness surface material whatever the orientation of the toy.

Ensure that the metal disc lies flat on the surface; if not, the force might be applied over a reduced area.

#### **A.40 Sharpness of points (see 8.12)**

The reference is American Code of Federal Regulations, CFR Title 16, Part 1000 to end, §1500.48, Figure 1. Before its introduction into the American Code of Federal Regulations, the sharp point tester was extensively

tested, but it still fails points that do not in reality present a risk of injury to a child. There is no objective test in this European Standard to address this situation, and a more subjective assessment has to be made.

It is suggested that the sharp point tester is incorporated into a device which together with the sharp point tester represents a force of 4,5 N. The sharp point can then be assessed in the vertical position by allowing the sharp point tester to be used under its own mass with support.

#### **A.41 Flexibility of metallic wires (see 8.13)**

During the test, carefully check that the metallic wire actually bends at the position where it is clamped rather than the 120° movement being taken up by the flexibility within the length of the metallic wire.

#### **A.42 Leakage of liquid-filled teethers (see 8.15 and A.30)**

Care should be taken when using cobalt-chloride paper to ensure that any water detected results from leakage and not from condensation on the *teether*. The note indicates that the test is applied only after incubation at 37 °C ± 1 °C.

#### **A.43 Geometric shape of certain toys (see 8.16 and A.31)**

It is important to emphasise that the toy is applied to the templates under its own mass.

#### **A.44 Durability of mouth-actuated toys (see 8.17)**

This test method is based on ASTM F963 (8.13, test for mouth-actuated toys) and determines whether any components that fit entirely in the small parts cylinder are released after a specified volume of air has been passed through the mouthpiece of toy, with control on the maximum pressure that can be applied.

#### **A.45 Folding or sliding mechanisms (see 8.18)**

Ensure that fragile seats composed of such materials as textiles are not damaged by the test masses. When using a support for the test mass, the mass of the support should be considered as part of the load.

#### **A.46 Static strength (see 8.21)**

Where the child's mass is distributed in various positions on the toy, the tester should ascertain how the load is to be distributed. The centre of gravity is not taken into consideration, and sand bags or similar can be used.

#### **A.47 Kinetic energy of projectiles, bows and arrows (see 8.24)**

Where more than one type of *projectile* is supplied with the toy, the energy of these other *projectiles* should be assessed, as variations in mass and, in some systems, in the rigidity of the *projectile* can result in significant variations from *projectile* to *projectile*.

The kinetic energy of a *projectile* is determined from the equation:

$$\text{kinetic energy} = 1/2 m \times v^2$$

where

- $m$  is the mass of the *projectile*, in kilograms;
- $v$  is the velocity of the *projectile*, in metres per second.

#### A.48 Small balls (see 4.22 and 5.10)



Examples of objects which due to their *ball*-shaped design are covered by the definition of *ball* in 3.5 are:

- a *ball*-shaped part of a stacking toy;
- a removable or detachable *ball*-shaped part of a construction toy;
- a *ball*-shaped container with intended play-value.



Dice are not covered by the definition in 3.5.

The definition in 3.5 refers to spherical, ovoid or ellipsoidal objects. There is presently no scientific data available to define an exact ratio between the major and the minor axes in this definition. However, the present interpretation is that these objects would typically have a ratio between the major and the minor axes higher than 70 %. Cylindrical objects and cylindrical objects with rounded ends are not included by the definition. An ambition for future revisions of the standard is to gather scientific data that will support the introduction of an exact ratio in the definition.

The hazard and risk intended to be covered by these requirements are different from what is covered by the small parts cylinder in 5.1 (toys intended for children under 36 months, general requirements) and 8.2 (small parts cylinder). The small parts cylinder addresses objects small enough to enter the child's lower throat.

Template E, as defined in  Figure 37  (see 8.32, small balls and suction cups test), addresses *balls* capable of entering and blocking the airways at the back of the mouth and upper throat. *Ball*-shaped objects trapped behind the ridge of the hard palate can be very difficult to remove due to a reflex that causes muscular constriction of the throat. Therefore, ventilation holes are not considered to be an appropriate way of avoiding the hazards related to small *balls* since a *ball* can be trapped in any position and therefore many large holes in all directions would be needed.

Unlike small parts which only present a hazard when they become detached, small *balls* present a *choking* hazard even when they are attached to a toy by a *cord*, provided that the total length of the *cord* and part of the *ball* is such that the *ball* can block the airway at the back of the mouth and upper throat. This length has been defined as 30 mm since this is identical to the depth of templates A and B.

A *ball* is considered to be "suspended freely" if it is attached to the end of a cord regardless of whether the cord is attached to the top of the *ball* or runs through a part of the *ball* (see example in  Figure 38 ). A single *ball* attached to the lowest part of a fixed loop attached to a toy (as in Figure A.3), is also covered by the requirements.

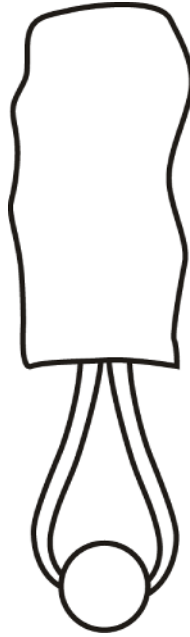

**Figure A.3 — Ball attached to a toy by a fixed loop**

*Balls* and other *ball*-shaped three-dimensional objects with minor diameters larger than 44,5 mm are seldom implicated in incidents since these objects are too large to become trapped behind the ridge of the hard palate.

It is the shape of the *ball* rather than the intended use of the *ball* that presents the hazard that could cause *choking*.

#### **A.49 Toy scooters (see 4.15.5)**

A body mass of 20 kg corresponds approximately to the mass (95th percentile) of a child of 3 years. A body mass of 50 kg corresponds approximately to the average mass of a child of 14 years.

The safety of scooters considered as sports equipment is covered by EN 14619.

It should be noted that the standard for scooters used as sports equipment is applicable to scooters intended for a user with a body mass of more than 35 kg and less than 100 kg. Therefore there are two types of scooters for the weight group 35 kg to 50 kg – those classified as *toy scooters* and those classified as sporting goods.

It has not been considered necessary to require brakes for *toy scooters* for very young children because they do not normally travel with great speed and are not considered able to operate a brake.

#### **A.50 Hemispheric-shaped toys (see 5.12)**

This requirement is intended to address the *suffocation* hazards associated with toys of certain shapes (e.g. cup-shape, bowl-shape or one half of an egg-shape) that can be placed over a young child's nose and mouth forming an airtight seal. The available data indicate that the children involved in fatalities were between the ages of 4 and 24 months while near misses involved children up to 36 months. (The same hazard is foreseen with *packaging* of the same shape, see A.56).



The US Consumer Product Safety Commission staff has analyzed the incident data and concluded the following regarding the dimensions of the containers involved in these incidents:

**Table A.1 — Dimensions**

<b>Hemispherical toys</b>	<b>Ranges</b>
Diameter range	69 mm to 97 mm
Depth range	41 mm to 51 mm
Volume range	100 ml to 177 ml

The work group observed children with cups in the diameter range of 51 mm to 114 mm. Based on these observations and the dimensions of the cups involved in the incidents, it was concluded that the size range of interest is 64 mm to 102 mm.

The two-hole positions described in Figure 16 a) and Figure 16 b) are intended to minimize the likelihood that both holes could be blocked simultaneously.

The size of the opening is specified to prevent a vacuum from forming. The openings are not intended as breathing holes.

A previous exception for "objects intended for drinking (e.g. tea set cups)" from the requirements in 5.12 has been deleted due to the European Commission's decision 2007/184/EC.

### **A.51 Magnets (see 4.23)**

These requirements are intended to address the hazards associated with ingestion of strong magnets (e.g. neodymium iron boron type magnets), that are capable of causing intestinal perforation or blockage. These hazards are additional to that associated with small parts (*choking*) (see A.26). The requirements apply regardless of the intended age of the user.

Magnets found by children can be ingested. If more than one magnet, or one magnet and a ferromagnetic object (for example iron or nickel) is ingested, the objects can attract to each other across intestinal walls and cause perforation or blockage, which can cause severe injuries that can be fatal.

Several accidents, including one fatality, have been reported involving ingestion of magnets resulting in perforation or blockage of the intestines. Most accidents have occurred with children between the ages of 10 months and 8 years. The majority of the accidents involve strong magnets used in magnetic building sets and in several cases surgery was required to remove the magnets from children's intestines. Medical signs associated with intestinal perforation or blockage can easily be misinterpreted since many children exhibit only flu-like symptoms. Such misinterpretations cause delay in the medical treatment and have led to medical consequences for children.

For the purpose of this European Standard, magnets or *magnetic components* that could be ingested are identified by using the small parts cylinder. The small parts cylinder was originally designed for identification of small parts in toys intended for children under 36 months, which are capable of causing *choking*. It was not designed for identifying objects that can be ingested by older children. The decision to use the small parts cylinder also for assessment of magnets or *magnetic components* that can be ingested was made for practical reasons: The cylinder is a well known test template and it provides a safety margin since the magnets and *magnetic components* that have caused accidents all fit entirely in the cylinder with a large margin. The same principle has been applied in the requirements for *expanding material*.

The risk of magnets attracting each other across intestinal walls is reduced with decreasing magnet strength. A limit value in the form of a magnetic flux index has therefore been introduced to define what a sufficiently weak magnet is. Accident data indicates that only powerful magnets have been involved in all known ingestion incidents to date. The data also suggests that magnet ingestion was not a problem in toys until powerful

magnets (such as neodymium iron boron magnets) became cost effective and commonplace several years ago. Ceramic, rubberized, and ferrite magnets have substantially lower attractive forces. A limit value for the magnetic flux index of  $50 \text{ kG}^2\text{mm}^2$  ( $0,5 \text{ T}^2\text{mm}^2$ ) is considered appropriate to ensure, with a safety margin, that powerful magnets of the type that have been involved in incidents will not be permitted for use in toys if they fit entirely in the small parts cylinder. The one known fatality occurred with a magnet from a magnetic building set with a flux index of  $343 \text{ kG}^2\text{mm}^2$  ( $3,4 \text{ T}^2\text{mm}^2$ ). By introducing the flux index limit the risk of injuries with magnets has been minimised. New data in the future will be used to assess if the chosen requirements are still appropriate.

More than 80 % of the known accidents have occurred with magnetic building sets. Magnetic building sets are subject to the requirements in this European Standard.

Other considerations were taken into account in evaluating the risks associated with ingestion of magnets. Perforation of intestinal walls can occur if the blood supply to a part of an intestinal wall is cut off, for example by the pressure exerted by two magnets that are attracted to each other across the walls. According to a theoretical medical study, a pressure of  $0,0016 \text{ N/mm}^2$  (12 mmHg) could, in a worst-case situation, cause such a cut off of the blood supply. Virtually all magnets on the market are capable of producing this level of pressure.

The probability that two weak magnets (flux index below  $50 \text{ kG}^2\text{mm}^2$  ( $0,5 \text{ T}^2\text{mm}^2$ )) will be transported through the intestinal system and end up on opposite sides of the intestinal walls at a position where the intestinal wall is extremely thin is considered to be very low. It would require not only that the two magnets are ingested on different occasions but also that the intestinal contents do not prevent the magnets from travelling along the walls and eventually finding each other on opposite sides of two walls by accident. For strong magnets the situation is different, since they attract each other over a longer distance with a force than can overcome obstructions presented by e.g. intestinal contents.

Furthermore, for a correct calculation of the magnetic pressure, both the flux density and the contact area need to be measured. The equation to calculate magnetic pressure is:

$$P = \frac{\alpha \times B^2 \times A_p}{A_c}$$

where

$P$  is the pressure;

$\alpha$  is a constant;

$B$  is the flux density (in Gauss or Tesla);

$A_p$  is the pole area of the magnet;

$A_c$  is the contact area between the magnet and whatever surface the magnet exerts the pressure on.

The contact area between a magnet or a *magnetic component* and the object to which it is attracted, is often very difficult to measure accurately due to unevenly shaped magnets or *magnetic components*.

The flux index, however, can be calculated using the pole area of the magnet and the flux density at the surface of the magnet or *magnetic component*. The flux index is therefore presently considered to be the best available measure for classification of hazardous magnets.

Two or more magnets can attract each other and form a compound magnet with a higher flux index than each single magnet. The flux index will not double if two equally strong magnets are attracted to each other and the increase in flux index will be relatively smaller for every new magnet that is added and will depend on magnetic material, shape, cross-section etc. Ingestion of multiple magnets has only been observed with stronger magnets and there is no accident data regarding weak magnets close to the flux index limit forming a (stronger) compound magnet. Therefore no additional test method for compound magnets is introduced.

Toys that contain magnets and which can be expected to become wet during normal and foreseeable use are subjected to a soaking test to ensure that glued magnets do not detach when the toy is wet. Also wooden toys are subjected to the test since the properties of wood (such as size of holes) can change even with changes in air humidity.

In some cases magnets are recessed and can therefore not be subjected to the normal tension and torque test. Examples of toys have been found where a magnet has become detached by another magnet. A tension test for magnets has therefore been introduced to minimize the risk that such magnets become detached during normal and foreseeable play.

For toys that comprise only one *magnetic component*, that toy is considered to meet the definition of a *magnetic component* (see [A2](#) 3.34 [A2](#)).

*Functional magnets in electrical or electronic components of toys* are not considered to present the same risk as magnets that form part of the play pattern. The use of magnets in these components may not be recognized, as they will be present inside electrical motors or in relays in electronic printing boards. None of the reported accidents has been linked to magnets released from electrical or electronic components.

*Magnetic/electrical experimental sets* that are intended for children over 8 years are excluded from the requirements in 4.23.2 and instead they are required to carry a warning. The exception applies only to the more advanced experimental sets that include building of electrical motors, loudspeakers, doorbells etc., i.e. products that need both magnetism and electricity for their function. *Magnetic/electrical experimental sets* that are intended for children under 8 years are therefore required to comply with the requirements in 4.23.2.

## A.52 Yo-yo balls (see 4.24)

This requirement has been defined taking into account the neck circumference of a child aged 6 years (250 mm for girls).

If it is assumed that the hazard for strangulation is present when a tether made of *elastic material* becomes wound at least 3 times around the neck, the following applies:

Maximum allowable length of the tether made of *elastic material* during use  $L$ :  $250 \times 3 = 750$  (values in millimetres).

This can be achieved by limiting the ratio between the mass (expressed in grams) and the elastic constant  $k$  to 2,2 (see Equation A.1).

$$(m/k) < 2,2 \quad (\text{A.1})$$

where  $m$  is expressed in grams

and by limiting the initial length  $l_0$  to less than 370 mm (i.e. one half of 750 mm) (see Equation A.2)

$$l_0 < 370 \quad (\text{A.2})$$

where  $l_0$  is expressed in millimetres.

With regard to physical background the following applies:

When rotating a *yo-yo ball* a centripetal force is applied to the *ball*. The relation between this force and the rotating speed is:

$$F_{\text{centripetal}} = m\omega^2 L \quad (\text{A.3})$$

where

- $L$  is the length of the tether made of *elastic material*;
- $\omega$  is the angular velocity;
- $m$  is the total mass of the *yo-yo ball* (the total mass of the *yo-yo ball* is considered, to simplify the measurements, since, usually, the mass of the tether made of *elastic material* is much smaller than the mass of the *ball*).

Assuming that the tether made of *elastic material* has a linear behaviour:

$$F_{\text{elastic}} = kl \tag{A.4}$$

where

- $k$  is the elastic constant of the tether;
- $l$  is the incremental length due to the elasticity of the tether made of *elastic material*.

The length under a force  $F_{\text{elastic}}$  is:

$$L = l_0 + (F_{\text{elastic}} / k) \tag{A.5}$$

where

- $l_0$  is the length of the tether made of *elastic material* in an unloaded condition.

In an equilibrium state:

$$F_{\text{elastic}} = F_{\text{centripetal}} \tag{A.6}$$

and thus:

$$kl = m\omega^2(l + l_0) \tag{A.7}$$

where

- $l_0$  is the length of the tether made of *elastic material* in an unloaded condition;
- $l$  is the incremental length due to the elasticity of the tether made of *elastic material*

and thus the elongation of the tether made of *elastic material* during the movement is:

$$l = \frac{m\omega^2 l_0}{k - m\omega^2} \tag{A.8}$$

and the total length during use is:

$$L = l_0 + m\omega^2 l_0 / (k - m\omega^2) = Zl_0 \tag{A.9}$$

where

- $Z$  is the elongation coefficient which depends upon the mass, the angular velocity and  $k$ , and it is equal to:

$$Z = 1 + \frac{m\omega^2}{k - m\omega^2} \quad (\text{A.10})$$

If the other parameters are kept constant (for example:  $k = 8 \text{ N/m}$ ;  $\omega = 15 \text{ rad/s}$ ) and the mass is changed the following situation occurs (see Figure A.4 where the horizontal axis shows the mass, and the vertical axis the value of  $Z$ ).

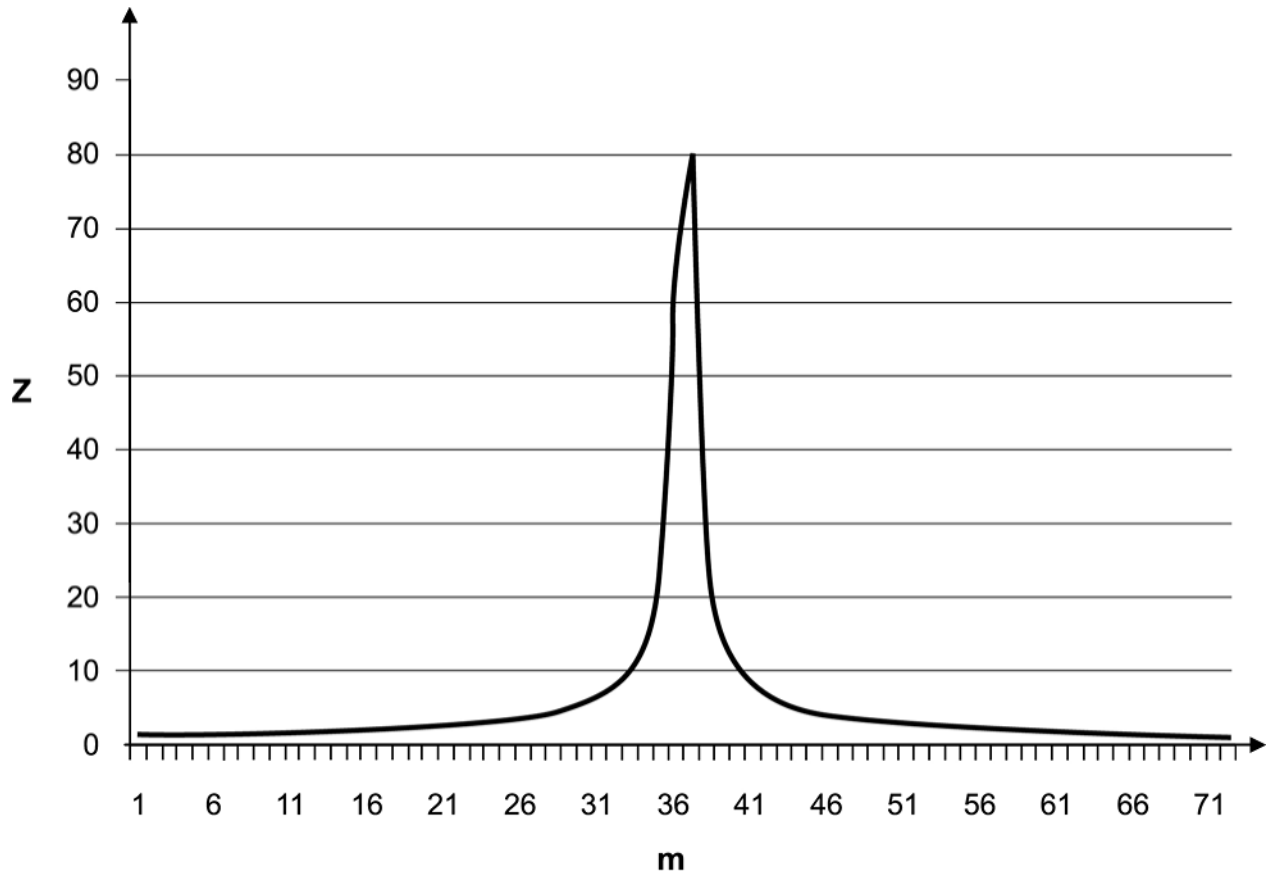

Figure A.4 — Graphic of elongation coefficient  $Z$  vs. mass

Thus, until  $m\omega^2$  is far from the value of  $k$  (e.g.  $m\omega^2$  is less than one half of the value of  $k$ ) the increment of length due to the rotation will be small (the total length will not be greater than the double of the initial length). However, when  $m\omega^2$  is close to  $k$ , the increment of length becomes very large (theoretically the length can become infinite).

In practice,  $L$  will be  $< 2 l_0$  until  $m\omega^2 < 0,5 \times k$ .

Trials show that an adult can give to the *yo-yo ball* an angular velocity of about 2,4 revolutions per second ( $\omega = 15 \text{ rad/s}$ ).

At this angular velocity, the length of the *cord* during of the *yo-yo ball* will not more than double until (see Equation A.11)

$$m < 2,2 \times k \quad (\text{A.11})$$

where  $m$  is expressed in g.

Thus, by defining the requirements that

- the ratio between the mass (expressed in grams) and the elasticity coefficient  $k$  shall be not greater than 2,2, and
- $l_0$  shall be not greater than 370 mm

it can be ensured that the total length of the *cord* of the *yo-yo ball* during use will be less than 750 mm and therefore not possible to wind three times around the neck of a 6-year-old girl.

### **A.53 Straps intended to be worn fully or partially around the neck (see 5.14)**

This requirement applies only to *straps* intended to be worn fully or partially around the neck. Toy safety harnesses, toy-backpack shoulder *straps*, and the *straps* of toy bag/bucket/box handles are not covered by this requirement.

*Straps* of binoculars, guitars or other toys intended to be worn fully or partially around the neck are examples of *straps* covered by this requirement.

### **A.54 Suction cups (see 5.13)**

This requirement is intended to address the hazards associated with *suction cups*, should they enter and block the airways at the back of the mouth and upper throat.

Fatal accidents are known to have occurred with *suction cups* which did not fit in the small parts cylinder. Therefore, it is necessary that *suction cups* which are loose or become detached during the required tests, do not pass entirely through template E.

*Suction cups* attached to a toy by a *cord* are not considered to present the same hazard as small *balls* on *cords*. Small *balls* trapped behind the ridge of the hard palate can be very difficult to remove, even when attached to a *cord*, due to a reflex that causes muscular constriction of the throat. The reflex is however related to the shape of the object and has not been observed in connection with *suction cups*. *Suction cups* that are attached to a toy by a *cord* and that do not become detached when subjected to the required tests, are therefore considered not to present the same hazard. The *cord* is considered to facilitate the removal of *suction cups*, for example, if they are unintentionally inhaled or ingested by a child who is under adult supervision.

### **A.55 Toys attached to food (see 4.25)**

These requirements are intended to address the *choking* hazard associated with unintentional ingestion or inhalation of toys that are attached to food, but they do not apply to the foodstuff as such.

Products covered by 4.25 are likely to be put in the mouth. It is essential that toys or toy-parts from such products cannot be swallowed or inhaled or become wedged in the mouth or pharynx or lodged over the entrance to the lower airways.

The products addressed in 4.25 are products where the toy or toy-component is attached to the foodstuff and where direct access to the entire toy or toy-component can be achieved without consuming the foodstuff (e.g. by removing the foodstuff with the hands as the food is not firmly attached) meaning that parts of the toy are *accessible*, without eating the food first. Such toys or parts of toys are not permitted to be a small part or a small *ball*. An example of such a product is a toy candy-lipstick where the toy-part of the product fits entirely in the small parts cylinder after removal of the candy part.

## A.56 Packaging (see Clause 6)

These requirements are intended to address the *suffocation* hazard associated with various types of *packaging*.

The requirements in Clause 6 a) and b) address the *suffocation* hazard associated with plastic film and plastic bags should they cover the mouth and nose or the head.

The requirements in Clause 6 c) and e) address the *choking* hazards presented by *packaging* which is a small *ball* and the *suffocation* hazard presented by *packaging* which is hemispheric-shaped (cf. the hazards described in A.48 and A.50). *Packaging* that is hemispherical-shaped could present the same *suffocation* hazard for a very young child as a toy of the same shape and is therefore covered by the same requirements as hemispherical shaped toys.

The requirements in Clause 6 d) address *choking* hazards associated with detachable parts of *packaging* which is either a small *ball*, or is cylindrical with a rounded end, should such parts become wedged in the mouth or pharynx or lodged over the entrance to the airways.

*Packaging* which has not been parted and has a cylindrical shape with a rounded end is not known to have been involved in accidents. However, incidents have occurred with parts of such *packaging*, e.g. in the form of half capsules. Therefore, requirements for cylindrical shapes with rounded ends, apply to parts (such as halves) of such *packaging*. If the parts are strongly attached to each other, this is considered to be an appropriate way of ensuring that one half cannot accidentally become lodged in the rear of the mouth cavity and cause *choking*. The requirement does not apply to parts of cylindrical *packaging* if the part has a major dimension of 64 mm or more since it is then considered to have a length that makes it possible to dislodge it should it have entered the rear of the mouth cavity (cf. the exclusion in 5.11 of play-figures with an overall length of 64 mm or more).

Examples of separable parts of cylindrical shaped *packaging* with rounded ends that does not comply with the requirement, provided that the parts pass entirely through template E, is shown in Figure A.5.



**Figure A.5 — Example of non-complying cylindrical shaped packaging with rounded ends**

An example of a cylindrical shaped *packaging* with rounded ends that complies with the requirement, provided that the attachment between the two parts does not break when submitted to the appropriate tests, is shown in Figure A.6.



**Figure A.6 — Example of complying cylindrical shaped packaging with rounded ends**

The requirements for *packaging* which is a small *ball* and for detachable parts of *packaging* that is either a small *ball* or has a cylindrical shape with a rounded end, apply to all age groups. This is based on the fact that children of all age groups might try to open such *packaging* with their teeth since opening with the hands could be difficult. Thus, this type of *packaging* is, from a risk point-of-view, considered as “intended to be used in the mouth”.

The European Commission’s Guidance document on *packaging* should be consulted for further details on classification of *packaging*.



## Annex B (informative)

### Significant technical changes between this European Standard and the previous version

Clause/Paragraph/Table/Figure	Change
General	The standard has been revised to reflect new particular safety requirements in directive 2009/48/EC, in comparison to 88/378/EEC
1	The exclusions in the scope for certain toys and products have been adapted to the exclusions made in directive 2009/48/EC
<sup>A2</sup> 2	The list of normative references to standards and guides have been updated. <sup>A2</sup>
3	<p>Terms and definitions of “asphyxiation”, “choking”, “suffocation”, “functional product”, “free-wheeling mechanism”, “fixed drive”, and “toy bag” added</p> <p><sup>A2</sup> Terms and definitions of “close-to-the-ear toy”, “hand-held toy”, “rattle”, “squeeze toy”, and “table-top or floor toy” have been amended.</p> <p>Terms and definitions of “cap-firing toy”, “emission sound pressure level”, “peak emission sound pressure level”, “percussion toy”, “pull-along or push toy”, “time-averaged emission sound pressure level”, “voice toy”, “wind toy”, and “maximum emission sound pressure level” have been added. <sup>A2</sup></p>
<sup>A3</sup> 3.41	The definition of the term “paper” has been updated with the aim of clarification.
3.42	A new definition of the term “paperboard” has been introduced. <sup>A3</sup>
<sup>A3</sup> 3.67 <sup>A3</sup>	The term “free-wheeling” has been deleted from the definition of “free-wheeling toy bicycle”
4.6	Requirement added that breakable material enclosing expanding material, shall be removed before testing
4.8	Requirement added that splinters on surfaces and edges shall not present an unreasonable risk of injury
4.11	Requirements for mouth-actuated toys have been extended to cover all toys intended to be put in the mouth
4.18	The requirements for air-inflation inlets with stoppers on <i>aquatic toys</i> , have been extended to cover all inflatable toys
<sup>A2</sup> 4.20	<p>Requirements for both A weighted time-averaged emission sound pressure and C-weighted emission peak sound pressure level, apply to all toys clearly designed to emit sound with no exclusions.</p> <p>Three exposure categories have been introduced to take into account the fact that the effective time of sound emission from a</p>

	<p>toy under use can vary considerably.</p> <p>New or revised limit values are defined for eleven toy types which are those 10 defined in Clause 3 as well as “Toys using headphones or earphones”.</p> <p>The layout of the requirements has been changed to facilitate better understanding of the requirements. <sup>(A2)</sup></p>
4.25	New requirements for “toys attached to food” have been included
<sup>(A3)</sup> 5.1	An explanation that the term “fabric” used in the general exemptions includes felt and elastic fabric has been introduced. Subsequently the term “elastics” has been deleted from the exemption.
5.1a)	An additional test for removability has been added for paperboard components. <sup>(A3)</sup>
5.2	A separate requirement for a seam test has been introduced for soft-filled toys containing fibrous filling materials
5.12	The exclusion for “containers that are part of the packaging” has been deleted
<sup>(A3)</sup> 6	A change to the exemption for plastic bags has been introduced such that bags are in scope if they have an area of more than 100 x 100 mm. Subsequently the text “with an opening perimeter greater than 380 mm” has been removed from subclause 6 a). <sup>(A3)</sup>
<sup>(A1)</sup> 7.1	Introduction of a requirement to consider the good practice for visibility and legibility included in A.33, when elaborating warnings. <sup>(A1)</sup>
7.2	The requirements for warnings have been amended to state that the word warning shall precede all warnings and shall accompany the age warning symbol, and to state that the specific hazard calling for an age warning shall be indicated and, if necessary for the understanding, also the harm shall be indicated.
7.3 - 7.22	The wording of certain warnings has been amended
<sup>(A2)</sup> 7.14	The warning has been updated to reflect that certain percussion toys shall carry a warning. <sup>(A2)</sup>
<sup>(A3)</sup> 8.4.2.1	A tension force of 25 N, applicable to components made entirely of paperboard has been introduced in the test method. <sup>(A3)</sup>
8.4.2.2	A new seam test has been introduced for soft-filled toys containing fibrous filling materials
8.6	The tip-over test has been modified to specify that the tested toy shall be prevented from sliding or rolling during the test
<sup>(A2)</sup> 8.28	<p>Test methods have been updated and/or revised and specify how each of eleven toy types shall be tested.</p> <p>The layout of the test methods has been changed to facilitate better understanding of the methods. <sup>(A2)</sup></p>
<sup>(A2)</sup> Annex A	Annex A updated with rationale and explanations for the revision of 4.20 and 8.28. <sup>(A2)</sup>
<sup>(A2)</sup> Bibliography	Four items added to the Bibliography <sup>(A2)</sup>
<p>NOTE The technical changes referred include the significant technical changes from the EN revised but is not an exhaustive list of all modifications from the previous version.</p>	

## Annex ZA (informative)

### Clauses of this European Standard addressing essential requirements or other provisions of EU Directives

This European standard has been prepared under a mandate given to CEN by the European Commission and the European Free Trade Association to provide a means of conforming to Essential Requirements of the New Approach Directive 2009/48/EC.

Once this European Standard is cited in the Official Journal of the European Union under that Directive compliance with the clauses of this standard given in Table ZA.1 confers, within the limits of the scope of this European Standard, a presumption of conformity with the corresponding Essential Requirements of that Directive and associated EFTA regulations.

**Table ZA.1 — Relationship between this European Standard and the Essential Requirements of EU Directive 2009/48/EC**

Clause(s)/sub-clause(s) of this Part of EN 71	Essential Requirements (ERs) of Directive 2009/48/EC	Qualifying remarks/ Notes
1	Article 2	
Introduction; 1; 4; 5; 7	Article 10, 2 (General)	
1	Article 10, 3 (General)	
7	Article 11 (General)	
4.15.1.3; 4.15.1.4; 4.15.3; 4.15.4; 4.15.5.3; 4.15.5.4; 4.16	Annex II.I, 1 (Particular)	
4.5; 4.7; 4.8; 4.9; 4.10.2; 4.14.2; 4.15.1.3; 4.15.5.7; 4.17; 5.1; 5.2; 5.4; 5.7	Annex II.I, 2 (Particular)	
4.10; 4.15.1.3; 4.15.1.6; 4.15.5.4	Annex II.I, 3 (Particular)	
4.24; 5.4; 5.14	Annex II.I, 4 a) (Particular)	
4.3; 4.4; 4.14; 5.3; 5.12	Annex II.I, 4 b) (Particular)	
4.6; 4.12; 4.17; 4.22; 4.25; 5.1; 5.2; 5.8; 5.10; 5.11; 5.13	Annex II.I, 4 c) (Particular)	
4.6; 4.11; 4.12; 4.17; 4.18; 4.23; 4.25; 5.1; 5.2; 5.9	Annex II.I, 4 d) (Particular)	
6	Annex II.I, 4 e) (Particular)	
4.25; 6	Annex II.I, 4 f) (Particular)	
6 d)	Annex II.I, 4 g) (Particular)	
4.25	Annex II.I, 4 h) (Particular)	
4.18	Annex II.I, 5 (Particular)	
4.14.1	Annex II.I, 6 (Particular)	
4.15.1.5; 4.15.1.8; 4.15.2.3; 5.6	Annex II.I, 7 (Particular)	

<b>4.17</b>	<b>Annex II.I, 8</b>	(Particular)	
<b>4.19; 4.21</b>	<b>Annex II.I, 9 a) and b)</b>	(Particular)	
<b>4.20</b>	<b>Annex II.I, 10</b>	(Particular)	
<b>4.13</b>	<b>Annex II. IV, 2</b>		
<b>4.1; 5.5</b>	<b>Annex II.V, 1</b>		
<b>1</b>	<b>Annex I</b>		
<b>7</b>	<b>Annex V, Part A</b>	(Particular)	
<b>7.2</b>	<b>Annex V, Part B, 1</b>	(Particular)	
<b>7.5</b>	<b>Annex V, Part B, 3</b>	(Particular)	
<b>7.10</b>	<b>Annex V, Part B, 5</b>	(Particular)	
<b>7.4</b>	<b>Annex V, Part B, 6</b>	(Particular)	
<b>7.8</b>	<b>Annex V, Part B, 8</b>	(Particular)	
<b>7.11</b>	<b>Annex V, Part B, 9</b>	(Particular)	

**WARNING** — Other requirements and other EU Directives may be applicable to the product(s) falling within the scope of this standard.

## Bibliography

- [1] American Code of Federal Regulations, CFR Title 16 Part 1000 to end, §1501 and §1500.48
- [2] <sup>A3</sup> ASTM F963 <sup>A3</sup>, *Standard Consumer Safety Specification on Toy Safety*
- [3] EN 14619, *Roller sports equipment - Kick scooters - Safety requirements and test methods*
- [4] <sup>A3</sup> EN 14765, *Bicycles for young children — Safety requirements and test methods*
- [5] EN 62115, *Electric toys — Safety (IEC 62115 + A1)* <sup>A3</sup>
- [6] <sup>A2</sup> *deleted text* <sup>A2</sup>
- [7] ISO/IEC Guide 37:1995, *Instructions for use of products of consumer interest*
- [8] CEN/CENELEC Guide 11, *Product information relevant to consumers — Guidelines for standard developers*
- [9] CR 14379:2002, *Classification of toys — Guidelines*
- [10] CEN/TR 13387:2004, *Child use and care articles - Safety guidelines*
- [11] Age determination guidelines: Relating Children's Ages To Toy Characteristics and Play Behavior, September 2002, CPSC Staff document
- [12] Regulation (EC) No 765/2008 of the European Parliament and of the council of 9 July 2008
- [13] The European Commission, *An explanatory guidance document (to Directive 2009/48/EC)*
- [14] EN 13613, *Roller sports equipment — Skateboards — Safety requirements and test methods*
- [15] EN 13843, *Roller sports equipment - Inline-skates - Safety requirements and test methods*
- [16] EN 13899, *Roller sports equipment - Roller skates - Safety requirements and test methods*
- [17] 2007/184/EC: Commission Decision of 23 March 2007 concerning the publication of the reference of the standard EN 71-1:2005 Safety of Toys — Part 1: mechanical and physical properties regarding the technical requirements on hemispheric toys in accordance with Council Directive 88/378/EEC on the safety of toys, OJ L 85, 27.3.2007
- <sup>A2</sup>
- [18] 2003/10/EC on the minimum health and safety requirements regarding the exposure of workers to the risks arising from physical agents (noise)
- [19] PRICE G.R. Validation of the auditory hazard assessment algorithm for the human with impulse noise data. *J. Acoust. Soc. Am.* 2007, **122** pp. 2787–2802
- [20] “Noise from toys and its effect on hearing”, Institute of Sound and Vibration Research University of Southampton, 1997, (URN 97/944, Department of Trade and Industry)
- [21] ISO/IEC Guide 98-3, *Uncertainty of measurement — Part 3: Guide to the expression of uncertainty in measurement (GUM:1995)* <sup>A2</sup>

*This page deliberately set blank*



# British Standards Institution (BSI)

BSI is the national body responsible for preparing British Standards and other standards-related publications, information and services.

BSI is incorporated by Royal Charter. British Standards and other standardization products are published by BSI Standards Limited.

## About us

We bring together business, industry, government, consumers, innovators and others to shape their combined experience and expertise into standards-based solutions.

The knowledge embodied in our standards has been carefully assembled in a dependable format and refined through our open consultation process. Organizations of all sizes and across all sectors choose standards to help them achieve their goals.

## Information on standards

We can provide you with the knowledge that your organization needs to succeed. Find out more about British Standards by visiting our website at [bsigroup.com/standards](http://bsigroup.com/standards) or contacting our Customer Services team or Knowledge Centre.

## Buying standards

You can buy and download PDF versions of BSI publications, including British and adopted European and international standards, through our website at [bsigroup.com/shop](http://bsigroup.com/shop), where hard copies can also be purchased.

If you need international and foreign standards from other Standards Development Organizations, hard copies can be ordered from our Customer Services team.

## Subscriptions

Our range of subscription services are designed to make using standards easier for you. For further information on our subscription products go to [bsigroup.com/subscriptions](http://bsigroup.com/subscriptions).

With **British Standards Online (BSOL)** you'll have instant access to over 55,000 British and adopted European and international standards from your desktop. It's available 24/7 and is refreshed daily so you'll always be up to date.

You can keep in touch with standards developments and receive substantial discounts on the purchase price of standards, both in single copy and subscription format, by becoming a **BSI Subscribing Member**.

**PLUS** is an updating service exclusive to BSI Subscribing Members. You will automatically receive the latest hard copy of your standards when they're revised or replaced.

To find out more about becoming a BSI Subscribing Member and the benefits of membership, please visit [bsigroup.com/shop](http://bsigroup.com/shop).

With a **Multi-User Network Licence (MUNL)** you are able to host standards publications on your intranet. Licences can cover as few or as many users as you wish. With updates supplied as soon as they're available, you can be sure your documentation is current. For further information, email [bsmusales@bsigroup.com](mailto:bsmusales@bsigroup.com).

## BSI Group Headquarters

389 Chiswick High Road London W4 4AL UK

## Revisions

Our British Standards and other publications are updated by amendment or revision.

We continually improve the quality of our products and services to benefit your business. If you find an inaccuracy or ambiguity within a British Standard or other BSI publication please inform the Knowledge Centre.

## Copyright

All the data, software and documentation set out in all British Standards and other BSI publications are the property of and copyrighted by BSI, or some person or entity that owns copyright in the information used (such as the international standardization bodies) and has formally licensed such information to BSI for commercial publication and use. Except as permitted under the Copyright, Designs and Patents Act 1988 no extract may be reproduced, stored in a retrieval system or transmitted in any form or by any means – electronic, photocopying, recording or otherwise – without prior written permission from BSI. Details and advice can be obtained from the Copyright & Licensing Department.

## Useful Contacts:

### Customer Services

**Tel:** +44 845 086 9001

**Email (orders):** [orders@bsigroup.com](mailto:orders@bsigroup.com)

**Email (enquiries):** [cservices@bsigroup.com](mailto:cservices@bsigroup.com)

### Subscriptions

**Tel:** +44 845 086 9001

**Email:** [subscriptions@bsigroup.com](mailto:subscriptions@bsigroup.com)

### Knowledge Centre

**Tel:** +44 20 8996 7004

**Email:** [knowledgecentre@bsigroup.com](mailto:knowledgecentre@bsigroup.com)

### Copyright & Licensing

**Tel:** +44 20 8996 7070

**Email:** [copyright@bsigroup.com](mailto:copyright@bsigroup.com)



...making excellence a habit.™